

**APPROVED:**  
**Division Administrator**

By: \_\_\_\_\_  
**FEDERAL HIGHWAY ADMINISTRATION**

---

**Supplemental Technical Specification for**

**Settlement Sensors**

**SCDOT Designation: SC-M-203-7 (01/25)**

---

**1.0 DESCRIPTION**

**1.1** Furnish all necessary supervision, labor, material, equipment, and related services necessary to provide, install and maintain settlement sensors in accordance with the lines, grades, dimensions, and designs shown on the plans, these Supplemental Technical Specifications (STSS), or as directed by either the Resident Construction Engineer (RCE) or the Geotechnical Engineer-of-Record (GEOR). Measure, record and provide to the RCE and GEOR the elevations of the settlement sensors as required in this STS. Install settlement sensors in the presence of the RCE and/or the GEOR. Accommodate the RCE and GEOR in the monitoring of settlement sensors, as required.

**1.2** Settlement sensors shall consist of a steel plate with the attached sensor equipment designed to be buried within soil fill and connected to a liquid reservoir, which is set in stable ground that is not subject to settlement. Settlement measurements are referenced to the fluid level of the reservoir supported on stable ground. In addition, a settlement point/target will be located on each reservoir. Monitor the settlement point/target as required in this STS or as directed by either the RCE or the GEOR.

**2.0 MATERIALS**

**2.1** The settlement sensor shall consist of a 12-inch square, 1/4-inch thick steel plate with an attached vibrating wire pressure sensor (see Figure 1). Supply a liquid reservoir and readout panel in lockable, insulated, waterproof casing. The lock shall be weather resistant. Provide all keys to the RCE. Supply and attach a graduated scale to the liquid reservoir so that the liquid level can be checked visually. Supply the manufacturer's instruction and installation manual(s) for the settlement sensor. The sensor shall have the signal cable and tubing attached and factory saturated with a 60% deaired ethylene glycol antifreeze solution, ready for connection to the readout panel and liquid reservoir. The liquid reservoir shall have a connection to allow for flushing if necessary. Provide additional antifreeze solution to fill the liquid reservoir and saturate the tubing connections. Use a settlement sensor that is self-compensating for variations in barometric pressure and has a built in temperature sensor for correction of temperature variations. Vent the settlement sensor to the air space at the top of the liquid reservoir to accomplish the self-compensation for barometric pressure, and a moisture trap shall be included in series with the vent tubing. The settlement sensor shall have a minimum range of 5 ft, a resolution of 0.01 ft, and a system accuracy of  $\pm 0.02$  ft.

**2.2** A metal or wooden post shall be provided for mounting the liquid reservoir and readout panel. The post shall be long enough so that it can be set a minimum of 54 inches below the stable ground surface, and the readout panel will be mounted so that the bottom of the readout panel is no less than 24 inches off of the ground. The readout panel will be fully supported along the total height of the readout panel.

**2.3** Provide clean sand backfill meeting the requirements of A-1-a, A-1-b, A-2-4, A-2-5 and

A-3. Properly compact the clean sand backfill around the signal cable and tubing leading from the settlement plate to the post supporting the liquid reservoir and readout panel.

**2.4** Provide incidental conduit, hardware, fasteners, tools, electronic readouts and the like, as necessary to install the system in accordance with the manufacturer's manual and this STS. Install schedule 40 PVC conduit around the liquid-filled tubes and vented signal cable. The PVC conduit will have an inside diameter of no less than 1 inch. Extend the PVC conduit to the bottom of the trench leading to the settlement sensor and place a 90° turn to prevent pinching of liquid-filled tubes or vented signal cable (see Figure 2). Secure the PVC conduit to the support post using appropriate fasteners. The PVC conduit classification shall at a minimum meet the requirements of ASTM D1784, 14222. The conduit dimensions shall meet the requirements of ASTM D1785. The electronic readouts shall be compatible with the settlement sensor system selected by the Contractor. Provide dedicated survey targets for each readout panel location and place a survey target on either the readout panel or the support post. If the survey target is placed on the readout panel, ensure that attaching the survey target to the panel doesn't interfere with the operation of the panel or access to the inside of the panel.

### **3.0 SUBMITTALS**

**3.1** Submit the settlement sensors manufacturer's cut/specification sheet for the settlement sensor selected prior to purchase of settlement sensor for review and approval of the RCE and GEOR. Also submit the location for each readout panel for approval, so that the proper length of signal cable and tubing can be purchased. In addition, indicate the location of the benchmark to be used to survey the location of the settlement sensor (initial elevation) as well as the elevation of the survey target located on the readout panel or support post. Establish the benchmark on stable ground that is not subject to settlement. If the settlement sensors are to be placed in a location other than shown on the plans, contact the RCE and GEOR for approval of the revised location.

**3.2** Upon receipt of the settlement sensor, submit copies of the calibration sheets and the manufacturer's installation and instruction manual for review and approval by the RCE and GEOR, and make available the settlement sensor for inspection by the RCE and GEOR.

**3.3** Provide a Settlement Sensor Installation Plan that includes at a minimum the settlement sensor manufacturer's installation requirements. Identify a geotechnical engineer that will be responsible for installing the settlement sensor. Document the geotechnical engineer's experience in providing instrumentation services using a settlement sensor in accordance with the project plans and Contract Documents by providing a project summary, of at least 3 projects, that includes for each project the project name, role in providing instrumentation services, type of settlement sensor used, duration of the project (i.e. dates), magnitude of settlements, client name and address, name and phone number of representative of the consultant and owner for whom the work was performed and can attest to the successful completion of the work, and any other information relevant to demonstrating the geotechnical engineer's qualifications. In addition identify in the Settlement Sensor Installation Plan, a land surveyor licensed in the State of South Carolina who has been responsible for collecting elevation data to the nearest 0.01 feet for at least 5 projects in the last 5 years. The land surveyor shall be present at the work site at all times during collection of elevation data. The Contractor shall provide a detailed resume of the land surveyor's experience and qualifications. The land surveyor, as well as any replacement for the land surveyor, will be subject to the acceptance of the Department. Include the Plan as well a description of how damaged settlement sensors and readout panels will be repaired.

**3.4** Within 1 week following installation, submit an installation record for each settlement sensor and readout panel support post which includes the sensor and support post designation, station, offset, and elevation of the settlement sensor, and of the readout panel. The settlement sensor and readout panel shall be located to an accuracy of 0.01 feet (both vertically and horizontally). Indicate the location of settlement sensors, readout panels and benchmarks used on "As-Built" drawings.

#### **4.0 CONSTRUCTION REQUIREMENTS**

**4.1** Notify the RCE and GEOR at least 5 working days prior to the installation of settlement sensors.

**4.2** Ensure a firm level base is present on site on which heavy equipment and/or other necessary equipment can be operated safely under its own power for installation of settlement sensors.

**4.3** Protect the settlement sensors, readout panels and benchmarks from damage for the duration of the Contract or as directed otherwise by the RCE. Immediately notify the RCE and GEOR if any settlement sensor, readout panel or benchmark is damaged. Replace/repair the settlement sensor, readout panel or benchmark in accordance with the previously accepted Settlement Sensor Installation Plan.

**4.4** Accurately locate all settlement sensors and readout panels in the field in accordance with drawings and ensure that no conflicts exist between settlement sensors and readout panels and existing and proposed structures, utilities or other construction proposed or present at the site. Settlement sensors and readout panels may be adjusted by the Contractor, with the approval of the RCE and the GEOR, to avoid utilities, foundations, and all other underground construction.

**4.5** Install settlement sensors and readout panels prior to placement of embankment fill or retaining wall construction and following clearing and grubbing and installation of ground improvement in the immediate vicinity of each settlement sensor and readout panel. In addition, prior to fill placement, ensure that the settlement sensor and readout panel are working together.

**4.6** Survey the readout panel survey target daily while fill is being placed, and twice weekly after completion of fill placement, unless directed otherwise by the RCE in conjunction with the GEOR. In addition, survey the ground surface elevation above each settlement sensor twice weekly while fill is being placed, and once every two weeks when fill is not being placed, unless directed otherwise by the RCE or GEOR. The purpose of these measurements is to provide the GEOR with a time-history of the embankment or retaining wall height for correlation with settlement measurements. Provide survey data to the RCE and GEOR within 1 calendar week of data collection. Provide all survey data to the nearest 0.01 feet.

**4.7** Accommodate the RCE or GEOR during construction to provide safe and timely access to the readout panels for the purpose of obtaining measurements, as construction progresses, as required.

**4.8** Evaluation of the settlement data will be the responsibility of the GEOR.

**4.9** Once the Engineer has determined that the settlement sensors have served their purpose and are no longer needed, they shall be abandoned in-place. Remove all recoverable portions of the settlement sensor, likely consisting of only the liquid reservoir and readout panel. All recoverable instrumentation shall remain property of the Contractor. Remove, contain and properly dispose of the ethylene glycol antifreeze solution from the buried tubing that is left in place by use of either a vacuum pump or by blowing out the tubing with air pressure.

**5.0 METHOD OF MEASUREMENT**

**5.1** The number of settlement sensors, as provided in the plans, will be paid for at the contract unit price bid for "Monitoring Device - Settlement Sensors" which shall include all equipment, including but not limited to the settlement sensor, liquid reservoir, water proof casing; mobilization; labor; surveys; materials; incidentals and abandonment required by this STS.

**6.0 BASIS OF PAYMENT**

**6.1** The price and payment for this work shall be full compensation as measured in the prior Section of this STS based on the acceptance of the Settlement Sensor installation by the RCE and the GEOR.

**6.2** Payments shall be made under:

<b>Item No.</b>	<b>Pay Item</b>	<b>Pay Unit</b>
2038115	MON. DEVICE – SETTLEMENT SENSOR	EA

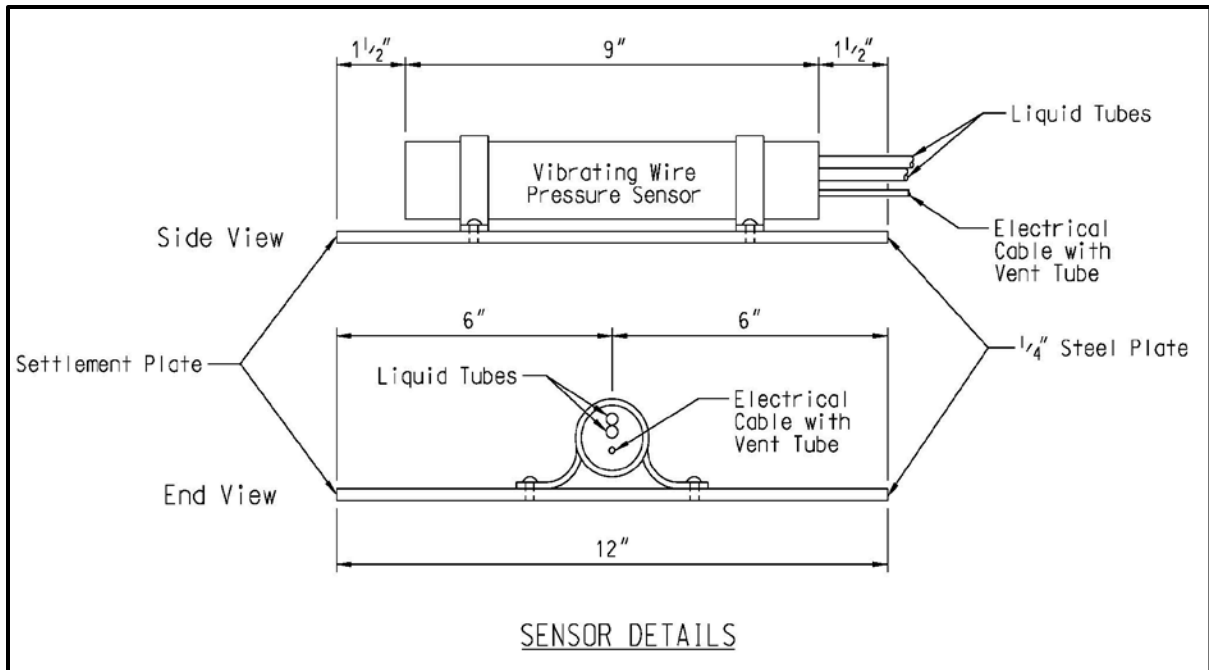

Figure 1

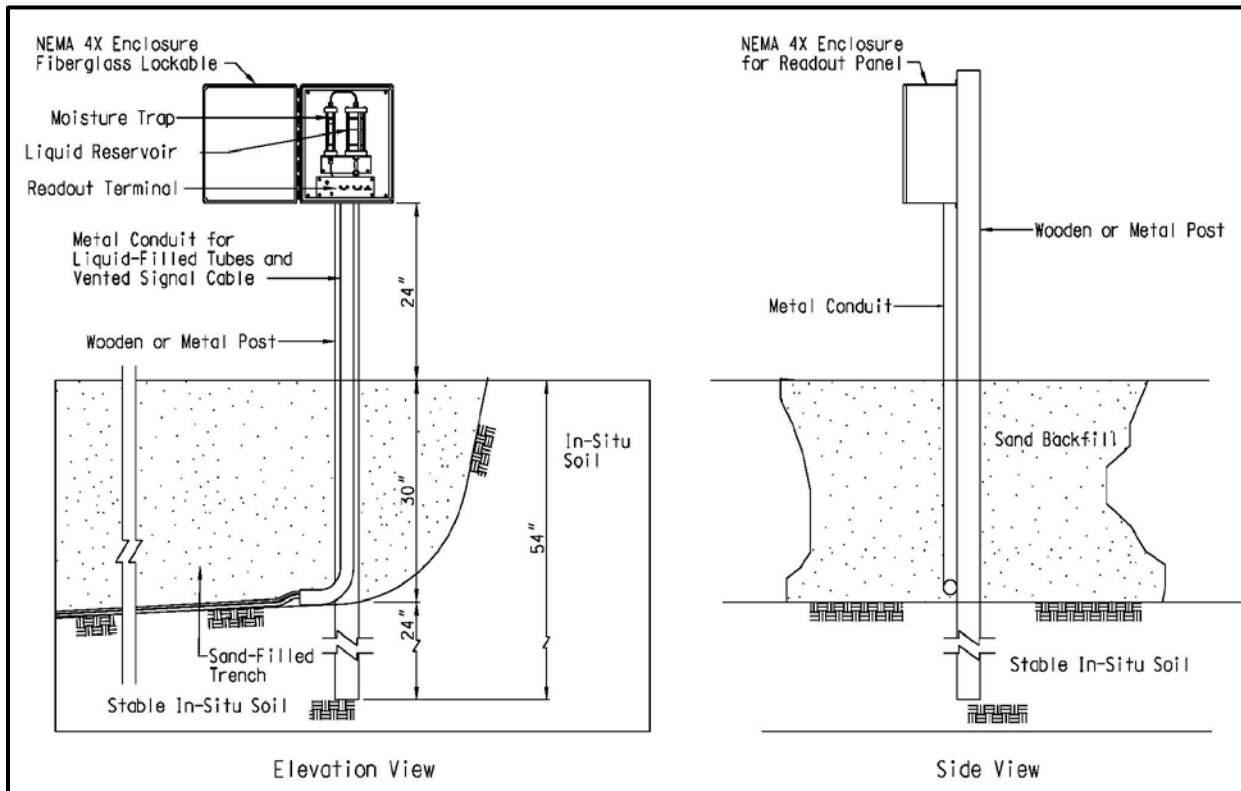

Figure 2