

**SPECIFICATIONS FOR THE REPLACEMENT OR NEW INSTALLATION OF
TRAFFIC COUNTING, CLASSIFICATION or WEIGH-IN-MOTION SYSTEMS**

() REPLACEMENT AND UPGRADE () NEW INSTALLATION

GENERAL DESCRIPTION

This work shall consist of furnishing and installing a Control Box with lightning suppression, Loop Wires, Piezo Film Sensors, Weigh-In-Motion sensors, lead-in wires, pull boxes, conduit and interconnections necessary to replace and upgrade the existing traffic counting, classification or Weigh-In-Motion devices which will be removed by the construction project. Should project conditions make it necessary to replace portions of the traffic counting, classification or Weigh-In-Motion system not mentioned above, a Supplemental Agreement would be negotiated to include the costs of those additional items. New installations shall consist of furnishing and installing a Control Box with lightning suppression, Loop Wires, Piezo Film Sensors, Weigh-In-Motion Sensors, lead-in wires, conduit, pull boxes, conduit and interconnections necessary for the installation. All equipment will be provided by the contractor, such as Traffic Counter, Modem, Solar 12V battery, Solar Panel and bracket, wood or metal pole or concrete pedestal for cabinet mounting. All work shall be performed in a satisfactory manner as determined by the SCDOT Engineer, and in accord with:

- A. Applicable drawings, maps and plans.
- B. SCDOT Standard Specifications for Highway Construction, latest edition with Special Provisions.
- C. National Electrical Code, latest edition.
- D. Uniform Traffic Control Manual.
- E. South Carolina Manual on Uniform Traffic Control Devices for Streets and Highways, latest edition.

The plans, drawings, and maps indicate the extent and general arrangement of the installations and are for guidance. Any omission shown or implied shall not be cause for deviating from the intent of the plans or specifications. If the Contractor deems any modifications of the plans or specifications necessary, details of such modifications and the reasons therefore, shall be submitted in writing to the Engineer for written approval prior to beginning such modified work.

Prospective bidders are urged and cautioned to visit the traffic counting and classification site and apprise themselves of all conditions, which will affect the performance of the work called for or reasonably implied by the contract. Submission of a bid shall

constitute sufficient evidence of this compliance and no allowance will be made for unreported conditions, which a prudent bidder would recognize as affecting the performance of the work called for in these specifications.

Bidders are requested to direct all technical questions regarding the bid specifications and requirements and the location of the existing traffic counting and classification site to the attention of:

Mr. Van B. Forrest, Jr.
Traffic Engineering, SCDOT
955 Park St.
Columbia, SC 29202
Phone: (803) 960-6709
Room 534

The Research and Materials Engineer shall approve all materials prior to being utilized. The Contractor shall submit for approval five (5) copies of descriptive literature, drawings and any requested design data for the materials proposed to be used. After approval, no substitutions for any approved materials may be made without the written approval of the Engineer.

- A. Loop Wire: The loop wire shall be splice free lengths in flexible tubing (IMSA SPEC. 51-5-1984), which shall be No. 14 AWG, stranded, single-conductor, type THHN, encased in a ¼ inch flexible tubing sheath or approved equal.
- B. Lead-in Cable: This shall be splice free lengths of IMSA SPEC. 50-2-1984, which shall be PVC sheathed, two conductor polyethylene insulated, No. 14 AWG, stranded cables; with an aluminum-polyester shield, and a stranded tinned copper drain wire. All lead-in cables for loops and piezo sensors that are installed on roadways are to be pulled to the nearest shoulder pull box and bored and jacked to a pull box near the control cabinet. No lead-in wires are to be cut across lanes unless prior approval is granted.
- C. Sealant: The loop sealant used to fill the saw cuts and other gaps, shall be of a type intended for traffic loop embedding. The cured sealant shall be semi-flexible, and be capable of adhering securely to concrete and asphalt. It shall be unaffected by freeze-thaw cycling, salts, gasoline, oil, sewerage and corrosive chemicals. It shall be proportioned and mixed per the manufacturer's instructions. Known suppliers include, but are not limited to, the following:
 - 1. Preco, Gold-Label Flex
 - 2. Detector Loop Sealant

- D. Waterproofing Splice Material: Splices shall be made using the materials listed below:
1. Cable Splice Kit: Commercially available, low voltage, waterproof splice-kit; to be Rusco 974 Sealant, Plymouth “PLYFLEX”, or 3-M “SCOTCH-LOK”, Unipak #3570, Resin 400 or approved equal. To be installed per manufacturer’s instructions.
 2. Vinyl plastic electrical tape (use where required). Cold and weather resistant, ¾ inch wide, 7 mil thickness (Scotch 33+ or approved equal).
 3. Liquid electrical coating (use where required). Fast-drying sealant compatible with vinyl tape, brush applied (3M, Scotchkote or approved equal).
 4. Underwater Splicing Kit: In very wet areas, where it may be required, an underwater splicing kit shall be used. This splicing kit shall consist of either Rusco 974 sealant application or a two-piece mold-body, with pourable resin sealing compound, funnels and end sealing strips (3M, Scotchcast 82-A1 or approved equal).
- E. Wire Crimps: The preferred splicing method shall use a commercial/industrial grade, copper-alloy, CRIMP-ON, with one end closed, of a size proper for the gauge of wires to be spliced, and the number of conductors. It shall be installed with the proper calibrated, ratchet type, crimping tool, intended for the purpose (NOT regular pliers). Note that wire nuts are not acceptable.
- F. Solder: The alternate method of splicing is to use solder, which shall be electronic-grade, rosin-core, 60 lead/40 tin. Acid-core solder is not acceptable, nor are acid type soldering pastes.
- G. Conduit: Conduit shall be as indicated on the sketches, but shall be at a minimum:
1. One inch schedule 80 PVC for all underground runs and from the road edge to boxes.
 2. ¾ inch schedule 80 PVC on poles above ground.
 3. On replacement sites, existing conduits are to be removed and new conduit are to be installed as specified in original contract unless prior approval is granted.

- H. Junction Boxes and Pull Boxes: Junction Boxes and pull boxes shall be of sufficient size to accommodate the necessary wires and other accessories for proper splicing of the loop wires. The boxes shall be either metal or plastic and shall be weatherproof. The number and configuration of the boxes will be determined by the installation site geometry and conditions.

*On replacement sites, existing junction boxes and pull boxes are to be removed and new boxes are to be installed as specified in original contract unless prior approval is granted.

- I. Piezo Film Sensor: Piezo film axle sensors shall be furnished and installed as needed to enable the system to operate as indicated in these Special Provisions. Materials and installation for the axle detectors, necessary lead wires and all connections shall be of the high quality needed for the sustained, long-term operation of the field station. Piezo film sensors shall operate within specification in both asphalt and Portland cement pavements constructed on all commonly encountered sub-base materials and soil types. AMP Roadtrax BL Class I (Wim) or II (Classification-Speed) piezo film sensors shall be used depending on type of installation. The sensor design must have been proven reliable in conditions similar to those in the United States. These sensors should at a minimum meet the requirements for class II piezoelectric sensors as outlined in FHWA report No. DP-88-76-006. See Attachment

The sensors should include all mounting hardware and installation grout. The supplied installation grout must be suitable for installation in both asphalt and portland cement pavements. The grout must have a short curing time to prevent unnecessary lane closure time. The grout should be of sufficient consistency to prevent "running" when being applied on road surfaces with a drainage cross-slope. Particulate matter within the grout must not separate or settle, nor must the grout shrink during the curing process.

Class I piezo film sensors must be Twelve (12) feet long or width of lane. Class II sensors must be six (6) feet in length and must be placed in the wheel path of the vehicle. The sensor must be active along the entire length. The sensors will be provided with a shielded lead in cable, which is at least 300 feet long, with no splices. Piezo film axle sensors shall be tested prior to and after installation.

- J. Control Cabinets: This specification sets forth the requirements for cabinets for housing and terminal strips, modems (where used), batteries and wiring for the vehicle loops and/or piezo cable sensors. The cabinets shall also be of sufficient size to contain the necessary meter(s). Cabinets are to be mounted on either posts or concrete bases, unless otherwise stipulated in the contract documents.

See Attachments

1. Physical and Mechanical Requirements

a. Materials

- (1) Cabinets shall be constructed of sheet aluminum alloy of 5052, with a minimum thickness of 0.125 inches (ASTM B209).
- (2) The cabinet surface shall have a smooth natural aluminum finish.
- (3) All exposed edges shall be free of burrs and pit marks.
- (4) All welds shall be neatly formed and free of cracks, blowholes, and other irregularities.
- (5) The Department may approve special design cabinets utilizing other special material combinations and gauges when such special designs are proposed by the Contractor.

b. Doors and Locks

- (1) All cabinets shall be provided with a hinged, rain tight and dust tight main door which shall encompass at least 80 percent of the full area of the cabinet front.
- (2) The main cabinet door shall be supplied with a Standard No. 2 Lock and the handle shall be capable of accommodating a pad-lock with a minimum 3/8" diameter shank.
- (3) The main cabinet door shall be NEMA Type with a neoprene gasket in the door. **See Figure 1**
- (4) Hinges shall be made of 14 gauge stainless steel and shall be attached by welding, riveting or tamper proof bolts.
- (5) Larger cabinets shall be furnished with a three-point lock system for the main door. Larger cabinets shall be furnished with a minimum of a two-position doorstop. The doorstop shall hold the door open at 90 degrees and at the full open position (minimum of 120 degrees). The doorstop shall be designed to lock into position and withstand the force of a 30-mph wind.

c. Ventilation: Cabinets shall be adequately vented by an approved watertight method.

d. Shelf Requirements: All cabinets shall have at least one shelf. Larger cabinets shall have two adjustable shelves. The range of adjustability shall be the full height of the cabinet in maximum increments of two inches. The bottom shelf will be at least 12

inches deep and the top of the shelf will be at least one inch less in depth. Other equipment shall not interfere with the adjustability of shelves.

e. Mounting Requirements

- (1) Pole mounting hardware shall be furnished with cabinets as a standard; however, if the contract documents stipulate a pedestal or other method of mounting; then the necessary hardware to accomplish the mounting shall be furnished.

See Figure 2

Angle arms shall be aluminum alloy 5052 minimum of ¼ inch thickness and a minimum width of 3 inch by 3 inch.

Galvanized anchor bolts, nuts, lock, washers, and flat washers in accordance with ASTM standard A153 shall be furnished with the cabinet. The anchor bolts shall be .750 inch in diameter and of sufficient length to support cabinet and equipment.

Each base mounted cabinet shall be furnished with a template for setting the anchor bolts in the footing.

Where base mounted control cabinets are specified, the reinforced concrete base, formwork and subgrade preparation shall be included in the price of the installation. Concrete for the base shall be class B, minimum compressive strength of 2500 psi.

- (2) Manufacturer identification: The manufacturer's name shall not appear on the outside of the cabinet, but shall appear on the inside of the cabinet door, with the year and month of manufacture. This can be done by a plate welded to the door or by a moisture resistant label (or other approved methods).

2. Ground Bussbar

- a. A copper ground bussbar shall be mounted on the side of the cabinet wall for the connection of AC neutral wires and chassis ground wires.
- b. If more than 1 ground bussbar is used in a cabinet, a minimum of a AWG No. 10 copper wire shall be used to interconnect them.

- c. The bussbar shall have at least two positions where an AWG No. 6 stranded copper wire can be attached. **See Figure 2A**
- 3. Documentation: Each cabinet shall be furnished with three copies of the cabinet wiring diagram and field wiring diagram unless otherwise stipulated in the contract documents.

K. Solar Panel:

- 1. General – The solar panel system shall consist of the solar panel (collector), voltage regulator and one or more rechargeable batteries. The power system shall be of sufficient capacity and design to enable it to operate without fault and within the full range of climatological conditions within South Carolina. The power system’s reserve capacity shall enable it to operate the equipment for 14 consecutive days of heavily overcast weather without the battery voltage nearing the point where power is too low to maintain the integrity of the equipment at the designed power level.

Each module shall be framed with bronze anodized extruded aluminum and shall be compatible with the mounting hardware. A weatherproof connection box shall be mounted on the back of the solar panel for connection of the output cable to the solar panel cable. This connection box shall have a fitting to accommodate the required conduit as indicated in Figure 3. **See Figure 3**

All cell modules shall be factory tested and labeled with the actual peak power and voltage output and peak current. All modules shall be approved by Factory Mutual Research for application in NEC Class 1, Division 2, Group D hazardous location.

- 2. Reliability and Environmental – All modules shall conform to the Federal Department of Energy’s Jet Propulsion Lab block V test criteria, and the following tests with no performance degradation.
 - Temperature coefficient of current 0.50 Ma/°C
 - Approximate effect of temperature on .37°/°C
power
 - Temperature coefficient of voltage -72.0 mv/°C
 - NOT C 45.0°C

- 3. Mechanical characteristics – solar panels shall conform to the following mechanical characteristics:

Weight:	Max 3.5 Pounds
Dimensions:	Max 18 inches x 12 inches x 1.75 inches
Output Cable:	15 feet long AWG 18-2 polyethylene jacketed

4. Miscellaneous – The manufacturer shall provide a warranty for the solar equipment for a period of not less than 2 years.

Mounting hardware shall be designed to support the solar equipment. Design shall be of such to accommodate a variety of attachment methods and mounting surfaces. All brackets and hardware shall be formed from high strength, corrosion resistance materials. All mounting hardware shall be adjustable to accommodate the directional requirements set forth by the solar cell manufacturer.

- L. Modems: The cabinet at each designated station shall contain a modem designed for communication with the data and the transfer of data to and from a modem at the central location. The modems shall depend upon the telephone line voltage for power. The Contractor shall furnish and install the field modems which shall be capable of transmitting data at variable rates with a minimum of 99.8% throughput of data when tested for six (6) consecutive hours and be compatible with the central modem. As a minimum transmission rates will include 1200 and 24020 baud. **See Attachment**

- M. Automatic Traffic Recorder: **See Figures 18 & 18A**

INSTALLATION PROCEDURES

- A. Saw Cuts: The location and size of each loop shall conform to the specifications. Loops shall be centered in the lane. The loop shall be six feet by six feet with the sides parallel and perpendicular to the direction of traffic. **See Figures 4 & Figures 5-7H.**

**Note: Figure 4 applies to all projects. The appropriate Figure 5-7H (lane layout) should be used for the roadway. If none of the layouts apply to the project, a special lane layout will be drawn and supplied to the contractor. If there is question as to which layout to use, please contact Van B. Forrest, Jr. at 803-960-6709.

Prior to cutting, the intended saw cut should be carefully marked on the pavement and approved by the Engineer.

The Contractor shall use a diamond or abrasive rotary power saw. The saw shall be a power driven walk-along model, not a hand tool.

Slots for loop wires and lead-in wires should be ¼” wide and cut so that the top wire is a minimum of one inch below the surface in concrete pavement and three inches in asphalt. **See Figure 8**

All saw cuts shall be washed out, blown dry, and be free of dust, grit, oil, and moisture before the placement of the wire. High pressure oil free compressed air shall be used to blow dry.

Pavement joints should also be avoided. However, when it is necessary to traverse a joint, a two (2) inch diameter hole about three (3) inches deep should be drilled, and enough slack provided in the loop wire to allow for expansion and contraction. **See Figure 9**

- B. Loop Wire: Each loop wire shall be continuous and splice free. Further, any wire with cuts, breaks, or nicks in the insulation shall not be accepted. All loops shall be wired in the counter-clockwise direction and shall have four turns of the wire. **See Figure 10**

Each loop detector shall be formed by installing in a separate cut, one (1) continuous length of single conductor wire, from the nearest approved pullbox, around the loop the specified number of turns, then back to the pullbox.

The loop wire shall be pressed to the bottom of the saw cut slot. A roller or blunt stick (similar to a paint stirrer) shall be used to seat the wire. In no case shall a sharp tool or screwdriver be used for this purpose.

The wire shall be laid in the slot so that there are no kinks or curls and no straining or stretching of the insulation around the corner of the slot, or at the junction.

After placing the wire in the slot, it shall be rechecked for slack, raised portions and tightness. The wire shall be depressed to the bottom of the slot and pressed against one another. One-inch lengths of one-half (1/2) inch closed cell backer rod may be used at two-foot spacings to help hold the wire down in the slot. Alternatively, a bead of loop sealant may be placed in the bottom of the saw slot, the wires installed and then the remaining sealant installed. The loop wires should be fully encapsulated in the sealant.

The loop wire shall be enclosed in the conduit from the roadway edge to the pullbox. Galvanized steel conduit should be used under curbs, driveways, or shoulders. **See Figure 11**

Each loop shall be tested before and after sealing. The inductance shall be in the range of 50 to 800 micro-Henrys. The insulation resistance measured to earth ground should be greater than 100 megohms at 500 volts DC. A meggar tester shall be provided to the Department at the end of the contract.

Note: The Megger test required before and after sealing shall be submitted to the Engineer in writing.

- C. **Loop lead in wire:** shall be extended splice-free to the pullbox. If the splices are required, every effort should be made to locate them in a pullbox. Each pair of lead in wires, exclusive of shielded cable, shall be twisted with three to five turns per foot before placement into saw slot, conduit or pullbox. Twisting of different loop pairs of wires together shall not be permitted.

Sufficient slack shall be left in both the lead in cable and the loop wire, so that the splice may be moved three (3) feet from the front of the pullbox. The slack shall be neatly coiled and nylon tied after completion of the splice. **See Figure 12**

Each roadway loop shall have a separate two conductor lead in at the terminal strip. In the controller cabinet the lead in cable shall be uniquely identified by an insulated, preprinted sleeve, slipped over the wire before the attachment of a spade-lug connector. A spade-lug connector shall be soldered onto each loop lead-in wire. In the controller cabinet, the ground wire from each lead in cable shall not be connected. Rather it shall be cut off at the cable sheath, and left floating. **See Figure 13**

- D. **Piezo Film Sensors:** Piezo film axle sensors shall be furnished and installed as needed to enable the system to operate as indicated. Materials and installation for

axle detectors, necessary lead wires and all connections shall be of high quality needed for the sustained, long-term operation of the field station. Piezo film sensors are for use in the classification of vehicles. Piezo film sensors shall operate within specification in both asphalt and Portland cement pavements constructed on all commonly encountered sub-base materials and soil types. Axle detectors shall be installed and connected in accordance with the attached recommendations of the manufacturer.

Piezo film axle sensors shall be furnished and installed in a slot cut in the pavement and shall have an active length of six (6) feet. The depth of pavement cut for piezo film sensors shall be $\frac{3}{4}$ inches. The width of the cut shall be $\frac{3}{4}$ inches. The cable channel shall be installed flush with the pavement surface in accordance with manufacturer's specifications.

*Piezo film sensors shall be tested prior to and after installation.

A pull box shall be installed on the shoulder on the end of the conduit if any splices are required and/or if the control box is not located near the edge of the road. At least 12 inches of slack wire should be left in the pullbox for future maintenance. Any required splices should be located in the pullbox with at least 12 inches of slack wire before and after the splice.

The pullbox shall be like the control box in size and materials and waterproof. It shall be located below the surface and have a removable panel located on the top side to allow for future access to wires. Once the wiring is pulled through and completed, the remaining hole with the wire lead-ins coming through it should also be waterproofed by filling it with flexible, removable waterproof compound or sealant.

- E. Conduit: Rigid conduit encasement shall be provided for all conductors run to the junction boxes, pullboxes and/or control cabinets. All conduit installations shall conform to the provisions of the National Electrical Code, except where directed otherwise. Bonded slip joints will be permitted for joining rigid conduit to boxes. Where a standard coupling cannot be used, an approved threaded union coupling shall be used. All conduit ends shall be reamed to remove burrs and sharp edges. Damaged portions of galvanized surfaces and untreated threads resulting from field cuts shall be painted with a rust inhibitive paint. Conduit bends shall have a radius of not less than 12 times the nominal diameter of the conduit, unless otherwise provided.

Conduit which will be subject to regular pressure from traffic shall be laid to a depth of not less than 12 inches. On transverse crossing under shoulders, the conduit shall be placed at a depth of not less than 12 inches below grade. After the conduit has been installed and before the backfilling is started, the conduit installation shall be inspected and approved by the Engineer.

In backfilling trenches, the backfill material shall be placed and compacted in lifts of 6 inches or less. Any area disturbed as a result of the contractor's operations shall be restored to the satisfaction of the Engineer. Conduits, junction boxes, and metal poles throughout the system shall be bonded together and bonded to all ground rods by using grounding brushings on the conduit ends.

F. Control Box:

1. General – The boxes shall be located as indicated in the Site Sketches.

The control box shall be mounted on a post at least 30 feet from the roadway within the guidelines of the Roadside Design Guide concerning clearances of obstacles. Control boxes shall be a minimum of two feet behind guardrail sections. Treated wood support posts will be used whenever possible; elsewhere, galvanized steel channel posts shall be used. Where the shoulder is bordered by a concrete barrier, the conduit shall be carried to the outside of the barrier and the control box anchored to the far side of the barrier post. Conduit cannot be attached to the traffic side of a barrier unless it is mounted flush with or below the surface of the barrier surface. In some cases pedestal mounted boxes may be necessary.

See Figure 14

2. Terminal and Wiring – Terminal strips with a minimum of ten terminals each will be mounted inside each control box in order to connect the loop wires to the leads of the 9-pin connectors. At least 10 inches of slack lead-in wire shall be left in the control box before connecting the lead-ins to the terminal strip. Wires connected to the terminal strips will have insulated, solderless, spade-tongue terminals of the correct wire and/or stud size. Wires connected to the 9-pin connectors will be 18 gauge stranded conductors with PVC insulation. The wires will be a minimum of 10 inches long and twisted in pairs to match the loop lead-in wires. The terminal strips and 18-gauge wire are to be supplied by the contractor as part of the control box.

See Figures 15, 16 & 17

All wiring for loops and piezo sensors shall be as recommended for connection to and compatible with the Department's existing equipment.

All connections are made via the terminal strip using the spade tongue connectors. At least 10 inches of slack lead-in wire should be left in the box before connecting each lead-in wire to the terminal strip.

The electrical lead-in can run in the same (if space is available) or different conduit as the loop lead-ins from the edge of the roadway to the box. If separate conduits are run for the lead-in wires, a pullbox shall be installed for each.

- G. Pullbox: A pullbox shall be installed in the shoulder on the end of the conduit if any splices are required and/or if the control box is not located on a guardrail, barrier, etc. near the edge of the road. At least 12 inches of slack lead-in wire should be left in the pullbox after pulling the wire through to the control box. Any required splices should be located in the pullbox with at least 12 inches of slack wire before and after the splice. Do not coil the loop lead-in wire. They should be laid in the box folded and loosely tied if necessary.

The pullbox shall be located below the surface, and have a removable panel located on the topside to allow future access to the wires. Once the wiring is pulled through and completed, the remaining hole with the wire lead-ins coming through it should also be waterproofed by filling it with a flexible, removable waterproof compound or sealant.

A sign for each site shall be provided by the Department indicating underground conduit and pullbox proximity. The signs shall be approximately 4" X 6" panels which say:

UNDERGROUND INSTALLATION
PLEASE CALL 1-803-737-2232
BEFORE DIGGING
SOUTH CAROLINA
DEPARTMENT OF TRANSPORTATION
OFFICE OF DATA SERVICES

The signs shall be mounted on galvanized metal channel posts.

The Engineer will designate where to install the signs.

The price of the signs shall be included in the price of the sites.

- H. Transient Protection:
1. Vehicle Loop Detector Inputs – Loop detector lead-ins shall be protected by a transient protection device or circuit to reduce the effect of transient voltages applied to the lead-in circuits. The protection device or circuit shall have the following minimum ratings:
 - a. Recurrent peak A.C. voltage greater than 15 volts.
 - b. Energy rating of 20 joules.

- c. Average power dissipation of 1 watt.
 - d. Peak current rating of 500 amperes for pulses less than 6 microseconds.
 - e. Standby current less than 1 millampere.
2. Field Wiring Terminals – The field wiring signal head output terminals shall be protected by a transient protection device or circuit to reduce the effect of transient voltages applied to the output terminal circuits. The protection device or circuit shall have the following minimum ratings:
- a. Recurrent peak A.C. voltage of 212 volts.
 - b. Energy rating of 20 joules.
 - c. Average power dissipation of .85 watt.
 - d. Peak current rating of 2000 amperes for pulses less than 6 microseconds.
 - e. Standby current less than 1 millampere.
3. Other Circuits: Other circuits shall have transient protection devices or circuits when called for in the contract documents. This would include surge on modems.

MEASUREMENT AND BASIS OF PAYMENT

General: Upon completion of all construction as defined in these Special Provisions at a location, the site will be placed in permanent operation and a 60-day observation period will begin. The purpose of this observation period is to assess the adequacy of the installation and operation of the equipment. During this 60-day observation period the contractor shall repair any defects in the installation work performed and make any adjustments deemed necessary by the Engineer. Should any failures occur during this observation period, the contractor shall begin to make necessary repairs within forty-eight hours of notification. Should necessary repairs not be completed within seventy-two hours of notification, the observation period shall stop and resume only after such repairs and replacement of materials have been made, inspected and approved. During this observation period, the contractor shall repair or replace any material and

equipment furnished by him that becomes defective, lost, or damaged. If the equipment does not operate according to the specifications during the operation period, the State shall have the option of returning the equipment at the vendor's cost.

FINAL ACCEPTANCE: Completion and final acceptance of the Traffic Counting and Classification or Weigh in Motion System shall be contingent upon successful completion of the 60-day observation period. The 60-day observation period shall be considered to be part of the work required to be completed by the final completion date specified for this project. Warranties and/or guaranties with respect to materials, parts, workmanship or performance shall not begin in force until final acceptance of the project. Payment for the system shall not be made until after the observation period has been successfully completed.

Payment will be made under:

<u>Item</u>	<u>Unit</u>
Traffic Monitoring Site Configuration	Site

Configuration Types: A, B & D

****Note: Configuration Type is dependent on the number of lanes and equipment/sensors installed.**



Piezo Polymer Sensors
Microfused Load Cells
Microfused Pressure Transducers

Dear Traffic Professional,

Thank you for your interest in the Measurement Specialties **Roadtrax**® Piezoelectric Traffic Sensors for *In the Road* and *Over the Road* applications. These sensors are being used for Weigh in Motion (WIM), vehicle classification and counting, speed detection, red light cameras, and parking area control.

Enclosed are the Product Specifications and Installation instructions for the **Roadtrax** BL Sensor. The BL Sensor (named for what it looks like - a Brass Linguini[®]!) is installed directly into a slot in the road. The sensor is only 1/16" thick and 1/4" wide (1.5mm x 6.5mm), but will provide 500 mV for a car. It is installed in a 3/4" wide by 3/4 - 1" deep (19mm x 19-25mm) slot in the road. Available in any length, it can be coiled for easy shipping and handling. These sensors reject road noise 10:1 and reduce ghost axles due to their flat design. This gives your electronics a clean easy to read signal that translates into more accurate count, speed, and WIM data. The BL Sensor is also now available in a Class I (Weigh in Motion) configuration. Both the Class I and the Class II sensors are available in a variety of different lengths from 6' to 13', with standard cable lengths of 100' or more (metric lengths of 2 m to 5.5m, with cable lengths standard from 35m to 100m). These sensors are directly compatible with all counters and WIM Systems which have a piezoelectric input. **Roadtrax** sensors are used on a global basis. Collectively, they have performed in an exemplary manner, giving unrivaled accuracy and dependability.

We are dedicated to working with you to ensure you have the right product to fully fit your needs. We can assist you in preparing for the installation of the sensors to ensure that this goes smoothly. We are committed to making the **Roadtrax** traffic sensors the best in the world. We appreciate the opportunity to work with you on your traffic data collection needs, and to assist you in making your job easier, safer and at the best cost.

We have prepared a new **INSTALLATION VIDEO** outlining the installation of the BL Sensor in the road. If you would like a copy of the video, just let us know and we will be happy to send you a copy. It is available in both video formats for use throughout the world.

Please give me a call if you have any questions. I would be happy to provide you with any further information or to quote you for your specific requirements.

Sincerely,

Donald Halvorsen

Donald L. Halvorsen
Director, Business Development

Sensor Products Division
950 Forge Avenue
Norristown, Pennsylvania 19403
Tel: (610) 650-1580
Fax: (610) 650-1509
e-mail: dhalvors@msiusa.com
Web Site: www.msiusa.com/sensors.htm

Sensor Products Division - Europe
Zum Roehrbrunnen 8
W 63303 Dreieich-Offenthal, Germany
Tel: +49 6074 862 822
Fax: +49 6074 862 823
e-mail: rhbrown@te-online.de



Roadtrax BL Traffic Sensors

Revised October 29, 1999

The MSI Roadtrax® Brass Linguini® axle sensor ... and why its the best sensor for you!!

Great Signal

- ✓ Positive signal as tires pass over the sensor
- ✓ High output - detects small vehicles - motorcycles, even bicycles
- ✓ Good dynamic range - can work with large to small vehicles
- ✓ Reduced Bow Wave
- ✓ Reduced Road Flexing noise
- ✓ High Signal to Noise Ratio for ease of signal processing
- ✓ High capacitance - can drive long cables
- ✓ Works even for slow speeds

Easy to handle

- ✓ Conforms to any road profile
- ✓ Stiff enough not to droop
- ✓ Coils in a 2'x2' (600x600mm) box
- ✓ Rugged so that it does not break in handling

Easy installation

- ✓ Installs in a 3/4" x 3/4" (19 x 19mm) cut in the road to minimize damage to the road
- ✓ Installs with fast curing epoxy, acrylic, or appropriate polyurethane
- ✓ No need for the heaters
- ✓ Smaller cut means less encapsulation material - a 6' BL sensor only uses under 2 gallon (2m sensor uses less that 1.5 liters)

Quality

- ✓ Sensors 100% tested for capacitance and insulation resistance, and then impacted every 1/4" (6mm) along the length of the sensor to determine the activity and uniformity of the sensor.
- ✓ Computerized process controls for the extrusion and polarization of the cable
- ✓ All data electronically archived
- ✓ All sensors Serial Numbered for traceability

Durability

- ✓ Triple sealed coax splice between the sensor and the passive cable
- ✓ The sensor will not be damaged by bending to a radius of > 1' (300mm)
- ✓ Will withstand normal handling without tender loving care
- ✓ Tested to 40 Million Equivalent Single Axle Loadings

Versatility

- ✓ Same sensor for over and in the road applications
- ✓ Surface sensors can be mounted permanently or temporarily
- ✓ Can be used in Portland Cement or Asphalt
- ✓ Several encapsulation techniques can be used - Epoxy, acrylic, or filled polyurethane

Great Passive cable

- ✓ Super tough High Density Polyethylene (HDPE)
- ✓ Rated as Waterproof for direct burial
- ✓ Low capacitance - 27 pF/foot (89 pF/m)
- ✓ Lengths from 100' to 300'(35-100m) standard - longer lengths on a custom basis

Customer Support

- ✓ Fast delivery - Units in stock
- ✓ Any length - 6', 8', 9', 10', 11', 12', and 13' - with a standard of 100' of passive cable but with the option of any length in multiples of 50'
- ✓ Now available in metric lengths - 2.5, 3.0, 3.5, 4.0, 4.5, 5.0 and 5.5 meters, with standard cable lengths of 35, 50, 75 and 100 meters
- ✓ Installation clips included with all sensors
- ✓ Installation instructions available on request
- ✓ Available Internationally
- ✓ On site installation training available

Measurement Specialties Inc, Sensor Products Division, 950 Forge Ave, Norristown, PA 19403 TEL: (610) 650 1580 FAX: (610) 650-1509



Roadtrax BL Traffic Sensors

Revised October 29, 1999

PRODUCT DESCRIPTION

The Roadtrax BL Traffic Sensor is designed for Permanent or Temporary installation into or onto the road surface for the collection of traffic data. The unique construction of the sensor allows it to be installed directly into the road in a flexible format so that it can conform to the profile of the road. The flat construction of the sensor gives an inherent rejection of road noise due to road bending, adjacent lanes, and bow waves for approaching vehicles. The small cut in the road minimizes the damage that is done to the road, speeds up the installation and reduces the amount of grout that is used for the installation. The Roadtrax BL sensor is available both as a Class I sensor for the highest level of uniformity needed for Weigh in Motion applications and as a Class II sensor which is more cost effective for Counting, Classifying, High speed Toll Booths, Speed Detection, and Red Light Cameras.

- # Uniform, **high amplitude** piezoelectric output **compatible with existing** counters and classifiers on the market.
- # **Excellent Signal to Noise Ratio** which has an inherent **10:1 rejection** of road noise due to road bending, adjacent lanes and bow waves of approaching vehicles.
- # **Easy installation** in a 3/4" x 3/4" (19 x 19mm) slot, which minimizes the disturbance of the road, decreases the depth of the road cut, and minimizes the amount of grout needed.
- # **Flexible sensor** - conforms to any road profile while maintaining a uniform distance to the road surface.
- # The **final installation is flush** with the road surface - snowplows will not do damage to the sensor.
- # **Durable** enough to withstand normal installation handling and **hundreds of millions ESAL's**.
- # All sensors are **100% tested and certified** for performance as a complete sensor prior to shipment.
- # Custom Passive Signal Cable with **High Density Polyethylene Jacket** which is rated for direct burial and resists nicks and cuts.

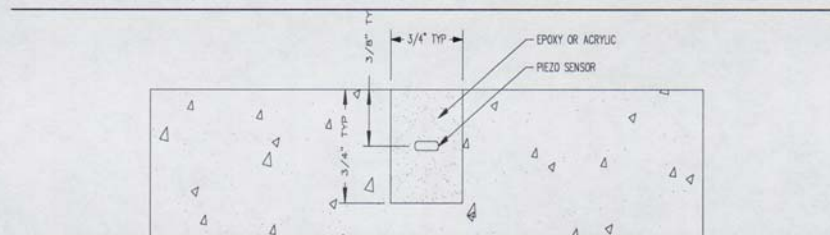

Measurement Specialties Inc, Sensor Products Division, 950 Forge Ave, Norristown, PA 19403 TEL: (610) 650 1580 FAX: (610) 650-1509



Roadtrax BL Traffic Sensors

Revised October 29, 1999

Performance Characteristics	
Output Uniformity	< $\pm 20\%$ for Class II (Classification) < $\pm 7\%$ for Class I (Weigh in Motion)
Operating Temperature Range	- 40 to 160° F (-40° to 70° C)
Temperature Sensitivity	0.2%/° F typ, dependent on the grout used
Typical Output Level	A wheel load of 400 pounds will produce a minimum output signal of 250 mV, at 70° F and 55 mph for a proper installation
Passive Signal Cable	RG 58C/U with a High Density Polyethylene Outer jacket that is rated for direct burial; 3/16" (4.75mm) OD
Product Life	40 Million ESAL's; dependent on the installation
Capacitance	See Chart
Weight	See Chart
Insulation Resistance	>500 M Ω
Packaging	All sensors are packaged two to the box in a 24"x20"x3"(600x550x75mm) corrugated cardboard box
Installation Brackets	Included. One bracket is used every 6" (150mm)

Specifications¹

The MSI BL Traffic sensor has the following specifications:

1. Center Core: 16 gauge, flat, braided, silver plated copper wire.
2. Piezoelectric Material: Highly compressed piezoelectric copolymer, P(VDF-TrFE)
3. Outer Sheath: 0.016" thick brass, CDA-260, ASTM B587-88
4. Final Dimensions: 0.260" wide x 0.063" thick; ± 0.005 "
5. Insulation resistance between core and shield: > 500 M Ω .
6. Piezoelectric Coefficient: ≥ 20 pC/N - nominal.
7. Passive Signal Cable: RG 58 type with a underground/direct burial rated outer jacket. The OD of the cable is 0.187" (4.75mm). The nominal capacitance of the cable is 27 pF/ft (89pF/m).
8. Sensors are packaged 2 per box. The box size is 24"x20"x3" (600x550x75mm).
9. Installation brackets are included with the sensors -- 1 bracket per 6" (150mm) of sensor length.

¹Although Measurement Specialties Inc. makes every effort to ensure the accuracy of the specifications at the time of publication, specifications for this product are subject to change without notice. Contact MSI for the most current information at +1 610 650 1580.



Roadtrax BL Traffic Sensors

Revised October 29, 1999

Sensor Length	Sensor Classification ²	Capacitance with 100' cable ³	Weight ⁴ pounds (kg)	Visible Brass Length	Installed Length ⁵	Part Number ⁶
6' (1.82m)	Class II	4.00 nF≤C≤10.00 nF	2.75 (1.25)	70" (1.78m)	76" (1.93m)	0-1005333-Y
8' (2.42m)	Class II	5.50 nF≤C≤11.50 nF	2.80 (1.27)	94" (2.38m)	100" (2.54m)	1-1005333-Y
9' (2.73m)	Class II	6.25 nF≤C≤12.25 nF	2.85 (1.30)	106" (2.69m)	112" (2.85m)	2-1005333-Y
10' (3.03m)	Class II	7.00 nF≤C≤13.00 nF	2.90 (1.32)	118" (3.00m)	124" (3.15m)	3-1005333-Y
11' (3.33m)	Class II	7.75 nF≤C≤13.75 nF	2.95 (1.34)	130" (3.30m)	136" (3.45m)	4-1005333-Y
12' (3.64m)	Class II	8.50 nF≤C≤14.50 nF	3.00 (1.36)	139" (3.53m)	145" (3.68m)	5-1005333-Y
13' (3.94m)	Class II	9.25 nF≤C≤15.25 nF	3.05 (1.39)	154" (3.91m)	160" (4.06m)	6-1005333-Y
6' (1.82m)	Class I (WIM)	4.00 nF≤C≤10.00 nF	2.75 (1.25)	70" (1.78m)	76" (1.93m)	1-1005438-Y
8' (2.42m)	Class I (WIM)	5.50 nF≤C≤11.50 nF	2.80 (1.27)	94" (2.38m)	100" (2.54m)	2-1005438-Y
9' (2.73m)	Class I (WIM)	6.25 nF≤C≤12.25 nF	2.85 (1.30)	106" (2.69m)	112" (2.85m)	3-1005438-Y
10' (3.03m)	Class I (WIM)	7.00 nF≤C≤13.00 nF	2.90 (1.32)	118" (3.00m)	124" (3.15m)	4-1005438-Y
11' (3.33m)	Class I (WIM)	7.75 nF≤C≤13.75 nF	2.95 (1.34)	130" (3.30m)	136" (3.45m)	5-1005438-Y
12' (3.64m)	Class I (WIM)	8.50 nF≤C≤14.50 nF	3.00 (1.36)	139" (3.53m)	145" (3.68m)	6-1005438-Y
13' (3.94m)	Class I (WIM)	9.25 nF≤C≤15.25 nF	3.05 (1.39)	154" (3.91m)	160" (4.06m)	7-1005438-Y
2.0m (6'7")	Class II	4.94 nF≤C≤10.94 nF	2.75 (1.25)	1.98 m (78")	2.14 m (84")	1-1005528-Z
2.5m (8'3")	Class II	6.17 nF≤C≤12.17 nF	2.85 (1.30)	2.48 m (98")	2.64 m (104")	2-1005528-Z
3.0m (9'11")	Class II	7.40 nF≤C≤13.40 nF	2.95 (1.35)	2.98 m (117")	3.14 m (123")	3-1005528-Z
3.5m (11'6")	Class II	8.63 nF≤C≤14.63 nF	3.05 (1.40)	3.48 m (137")	3.64 m (143")	4-1005528-Z
4.0m (13'2")	Class II	9.87 nF≤C≤15.87 nF	3.15 (1.45)	3.98 m (157")	4.14 m (163")	5-1005528-Z
4.5m (14'10")	Class II	11.09 nF≤C≤17.09 nF	3.25 (1.50)	4.48 m (177")	4.64 m (183")	6-1005528-Z
5.0m (16'6")	Class II	12.32 nF≤C≤18.32 nF	3.35 (1.55)	4.98 m (196")	5.14 m (202")	7-1005528-Z
5.5m (18'2")	Class II	13.55 nF≤C≤19.55 nF	3.45 (1.60)	5.48 m (216")	5.64 m (222")	8-1005528-Z
2.0m (6'7")	Class I (WIM)	4.94 nF≤C≤10.94 nF	2.75 (1.25)	1.98 m (78")	2.14 m (84")	1-1005527-Z
2.5m (8'3")	Class I (WIM)	6.17 nF≤C≤12.17 nF	2.85 (1.30)	2.48 m (98")	2.64 m (104")	2-1005527-Z
3.0m (9'11")	Class I (WIM)	7.40 nF≤C≤13.40 nF	2.95 (1.35)	2.98 m (117")	3.14 m (123")	3-1005527-Z
3.5m (11'6")	Class I (WIM)	8.63 nF≤C≤14.63 nF	3.05 (1.40)	3.48 m (137")	3.64 m (143")	4-1005527-Z
4.0m (13'2")	Class I (WIM)	9.87 nF≤C≤15.87 nF	3.15 (1.45)	3.98 m (157")	4.14 m (163")	5-1005527-Z
4.5m (14'10")	Class I (WIM)	11.09 nF≤C≤17.09 nF	3.25 (1.50)	4.48 m (177")	4.64 m (183")	6-1005527-Z
5.0m (16'6")	Class I (WIM)	12.32 nF≤C≤18.32 nF	3.35 (1.55)	4.98 m (196")	5.14 m (202")	7-1005527-Z
5.5m (18'2")	Class I (WIM)	13.55 nF≤C≤19.55 nF	3.45 (1.60)	5.48 m (216")	5.64 m (222")	8-1005527-Z

²Class II sensors have a uniformity of $\pm 20\%$ and are typically used for Classification purposes. Class I sensors have a uniformity of $\pm 7\%$ and are typically used for Weigh in Motion applications.

³Additional cable has a capacitance of 27 pF/ft (89 pF/m) or 2.7 nF/100' (2.2 nF/25m). Provided with each sensor is a test certificate with the actual tested value for the sensor. Field tests should be within $\pm 10\%$ of these values, at room temperature (70°F or 23°C).

⁴All sensors are packaged 2 per box. The box weighs 1.5 lbs (0.7 kg).

⁵This length refers to the installed length of the sensor. This is the minimum lane width for the installed sensor.

⁶The suffix refers to the cable length. Cable lengths for -Y are as follows: -1 @ 100', -2 @ 150', -3 @ 200', -4 @ 250', -5 @ 300'. Cable lengths for the -Z are as follows: -1 @ 35m, -2 @ 50m, -3 @ 75M, and -4 @ 100m.

Measurement Specialties Inc, Sensor Products Division, 950 Forge Ave, Norristown, PA 19403 TEL: (610) 650 1580 FAX: (610) 650-1509



Roadtrax BL Traffic Sensors
Revised October 29, 1999

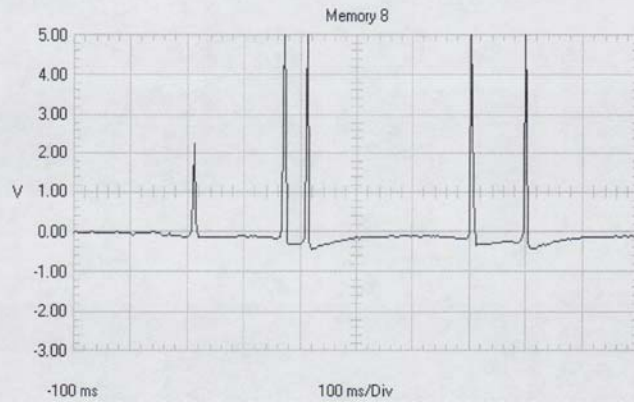

Datablock	
Name	= Memory 8
Date	= 5/20/97
Time	= 8:55:43 PM
Y Scale	= 1.00 V/Div
Y At 50%	= 1.00 V
X Scale	= 100 ms/Div
X At 0%	= -100 ms
X Size	= 250 (256)
Maximum	= 5.60 V
Minimum	= -0.44 V

AMP BL, I35n, brick truck, 6n

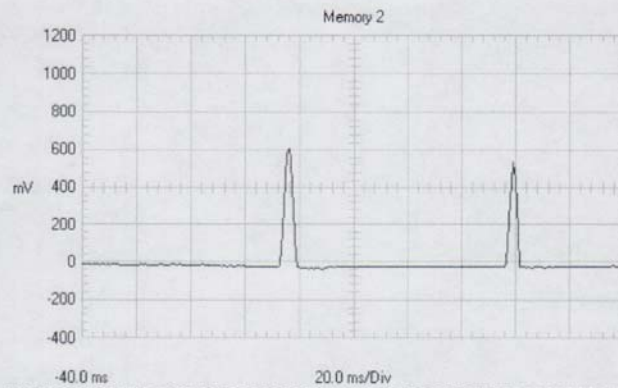

Datablock	
Name	= Memory 2
Date	= 6/14/97
Time	= 9:13:37 AM
Y Scale	= 200 mV/Div
Y At 50%	= 400 mV
X Scale	= 20.0 ms/Div
X At 0%	= -40.0 ms
X Size	= 250 (256)
Maximum	= 608 mV
Minimum	= -40 mV

AMP BL, A74 (England) 12' Sensor, Global 768, Car

Measurement Specialties Inc, Sensor Products Division, 950 Forge Ave, Norristown, PA 19403 TEL: (610) 650 1580 FAX: (610) 650-1509



Roadtrax BL Traffic Sensors
Revised October 29, 1999



Roadtrax BL Sensor taped to the road. 12' long with 100' passive cable. Chevy Caprice = 25 mph. 4/25/96. 1V/div vertical scale; 50 msec/div horizontal.

victoria rd, W, ford falcon

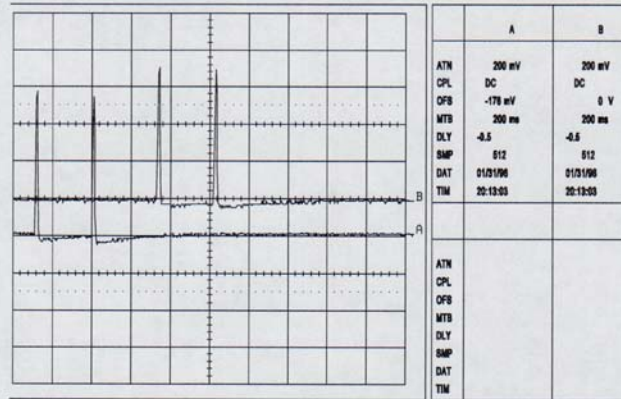

Roadtrax BL Sensor installed in an asphalt road using epoxy. 200mV/div vertical scale, 200 msec/div horizontal scale. 12' sensor with 100' cable. Mid sized car at 35 mph.

Measurement Specialties Inc, Sensor Products Division, 950 Forge Ave, Norristown, PA 19403 TEL: (610) 650 1580 FAX: (610) 650-1509



Roadtrax BL Traffic Sensors

Revised October 29, 1999

Read these instructions completely PRIOR TO INSTALLATION

Approved Installation Epoxies: E-Bond G-100, ECM P5G, Global Resin PU 200, IRD AS475

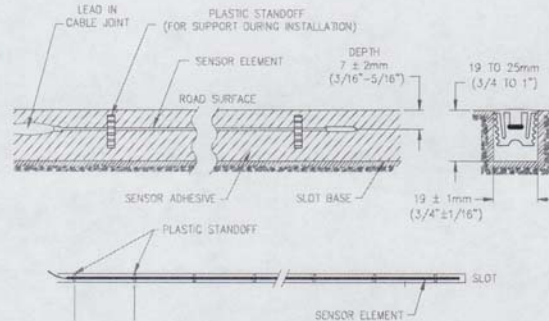

- Carefully mark the slot to be cut, perpendicular to the flow of traffic. Ensure that the sensors are properly positioned in the lane. Shorter sensors are positioned to one side; longer sensors are typically centered on the lane.
- Cut a slot 3/4" wide ($\pm 1/16"$) and 3/4" deep ($-0"$, $+1/4"$), (19 mm wide, ± 1 mm, 19 to 25 mm deep). The slot should be $\approx 6"$ (150 mm) longer than the sensor. The lead out should be centered on the slot. The lead out cable slot is typically 3/8" (9mm) wide and 3" (75mm) deep. It is normally done to the same specifications as the inductive loop and the homerun cables for these.
- It is strongly recommended that a 3/4" (19mm) wide diamond blade be used for cutting the slot, or that blades be ganged together to get a single 3/4" (19mm) wide cut. The slot should be wet cut to minimize damage to the road.
- Once all cutting is completed (including the inductive loops) sweep and wash out the debris left in the slot and ensure it is clean and dry. Use high pressure water, a power washer, or water and compressed air to clean ALL foreign matter out of the slot and 6" (150 mm) on all sides of the slot. Remove all excess water and debris with a vacuum cleaner and/or sweeping.
- Carefully dry the slot using torches, torpedo heaters, electric heaters, or natural evaporation, depending on weather conditions. Be very careful not to burn the asphalt if a torch is used. The slot needs to be clean and dry to ensure the chemical bonding of the grout to the pavement.
- Place a strip of 2" (50mm) wide duct tape along the pavement next to the slot. This facilitates leveling the grout and clean-up.
- Lay the sensor on the tape next to the slot. Ensure that the sensor is straight and flat. Place the clips on the sensor, about every 6" (150mm). Slightly bend the end of the sensor down at a 30 deg angle, so that it is below the surface. Do the same at the end with the passive cable, bending the sensor about 1" (25mm) from the lead attachment.
- Place the sensor in the slot, carefully pressing down on the brass element on either side of the clips. Press down only far enough so that the top of the clips are flush with the road surface. Once you have all of the clips in place, go back and press them in further, so that the top of the sensor is 3/8" (9mm) below the road surface. If the slot is cut to the proper depth, the clips will not be all the way to the bottom. The top of the clips will 1/8" (3mm) below the road surface.
- Block off the end of the slot where the cable exits using plumbers putty or foam backer rod. Ensure that there is an adequate 'dam' so that the encapsulation material does not flow out. The dam MUST be about 3-5" (75-125mm) past the end of the lead attachment area. The installation grout must completely encapsulate the lead attachment area. If ducting or conduit is used for the lead in cable, it should not extend to the lead attachment. It must stop 3-5" (75-125 mm) short of the lead attachment so that the lead attachment can be fully encapsulated.
- Test the sensor for Capacitance, Dissipation Factor and Resistance, according to the directions enclosed. Record the test results and the sensor serial number. This information should be stored in the counter cabinet or returned to a data storage file.
- Mix the grout according to the manufacturers instructions. Be sure to pre-mix the resin before combining the two parts since the filled materials have a tendency to settle. Fill the slot full of the encapsulation material. Using a trowel, distribute the encapsulation material along the sensor, and smooth it out.
- Remove the tape on the sides of the sensor as soon as the adhesive starts to cure.
- Carefully remove the plumbers putty or backer rod used to form the dams at the end of the sensor.
- Route the lead in cable through the slot cut for it, and cover with loop sealant or grout. NOTE: Hot Tar should not be used since the temperature is difficult to control and it can burn the cable.
- When the encapsulation material is fully cured, grind the top of the encapsulation material flush with the road using an angle grinder. The profile should be flat and flush with the road, ensuring that there are no concave portions.
- Clean up the site. When the encapsulation material is fully cured, it may be opened to traffic. Failure to wait for the encapsulation material to fully cure may ruin the installation and cause it to fail prematurely.

Measurement Specialties Inc, Sensor Products Division, 950 Forge Ave, Norristown, PA 19403 TEL: (610) 650 1580 FAX: (610) 650-1509



Roadtrax BL Traffic Sensors

Revised October 29, 1999

Important Notes and Hints:

- The quality of the road will affect the quality of the data. The roads should conform to ASTM specifications for Weigh in Motion applications.
- Diamond blades should be used on the road saw. The tolerance for the cut is 11/16" to 13/16". A 3/4" diamond blade is recommended for cutting the slot. Do not try to do two independent cuts as it is very difficult to achieve this level of accuracy.
- Wet cutting is preferred to dry cutting. The dry cutting forces particles into the side walls of the slot which are very difficult to thoroughly clean. This residue will diminish the adhesion of the adhesive to the road, potentially allowing for the premature failure of the sensor.
- The passive cable length should not exceed 300' without consulting the manufacturer. It is **STRONGLY** recommended that the sensors be ordered with sufficient cable to avoid splices. If splices are needed, only similar grade of RG-58 cable should be used, the splices must be soldered, and an approved splice kit used to waterproof the splice. MSI Sensors is not responsible for any problems arising from splicing the cable.
- Disposable gloves must be worn when working with the encapsulation material. Appropriate precautions should be taken, according to the encapsulation material manufacturer's instructions. Ensure you read and follow all safety instructions.
- Adequate traffic control is essential. Do not put any of your workers at risk.
- Ensure that the sensor is placed in the correct location on the road. Six foot sensors should be positioned in a wheel path, NOT in the center of the lane.
- Care should be taken when mixing the encapsulation material to minimize the amount of trapped air in the material. Do not lift the mixing paddle out of the encapsulation material while the mixing head is spinning. Stop the blade and then use a stirring paddle to scrape the edges of the can.
- If heaters are needed to speed the curing process for the grout, extreme care should be taken to ensure that the sensors are not destroyed. The maximum temperature that the sensors can withstand is 170°F!. An A-Frame should be constructed out of metal or plywood, and placed over the sensor. Warm air from a torpedo heater should be blown in horizontally into the A-Frame, but NEVER aimed directly at the sensor. The air temperature at the sensor location should not be higher than what can be tolerated by your hand for 20-30 seconds. If it is hotter than this, the sensor will lose its piezo activity and will not function.
- Once the sensor is installed and the grout is cured, it is recommended that any excessive grout be ground off, using an angle grinder. The best installation has the grout flush with the road surface to minimize any chance of the tires bridging over the sensor.
- Thin walled plastic tubing may be used to contain the homerun cable. In the unlikely event that the sensor needs to be replaced, the passive cable can then be pulled through the tubing, thereby eliminating the need for recutting the homerun slot.
- Read all of the directions carefully and completely prior to the installation. Ensure that you have all of the required equipment available. If there are any questions on the installation, call MSI Sensors and we will be happy to 'walk' you through the procedures.

Measurement Specialties Inc, Sensor Products Division, 950 Forge Ave, Norristown, PA 19403 TEL: (610) 650 1580 FAX: (610) 650-1509



Roadtrax BL Traffic Sensors

Revised October 29, 1999

Required/recommended tools and materials

- MSI BL Sensors with installation brackets. Sensors should be ordered with sufficient passive cable to go all the way to the control cabinet.
- Installation instructions. Read these instructions prior to the installation. There may need to be some adaptation of these instructions based on local conditions.
- Sensor support brackets. These are shipped in the box with the sensors.
- Installation encapsulation. See Recommended materials under **Frequently Asked Questions**. Approximately 1/2 to 1 gallon (1.5 to 3 liters) of material is needed per sensor. The slot must be carefully cut in order to ensure that it is not too deep; otherwise excessive material is used. Read, understand and follow the directions supplied by the manufacturer of the installation encapsulation. Adhere to the temperature limits imposed on the material to ensure adequate drying time is available. Follow all recommended safety precautions.
- Loop sealant material to cover the homerun cables. Amount used will depend on the length and width of the homerun cuts. Hot tar can only be used if the homerun cables are enclosed in conduit. The hot tar will destroy the passive signal cable if it is allowed to come into direct contact with the cable. Extreme care must be taken if using hot tar.
- Thin wall tubing for homerun cables. Minimum 3/8" (9mm) ID, flexible tubing. Materials for this tubing are typically flexible PVC or polyethylene. Sufficient quantity for all homeruns from the end of the sensors to the cabinet.
- PVC pipe, 2-3" (50-75mm) dia. For use as conduit for any underground runs from junction boxes to cabinets.
- PVC solvent and joints - as needed for any splices in the pipes.
- Wet cutting pavement saw. A self-propelled saw of at least 35 hp, fitted with a 14" (350mm) or larger blade. This saw must be capable of cutting a 3/4" wide x 1" deep (19mm wide x 19-25mm deep) cut in a single pass.
- Diamond Blades for the saw. Appropriate type for the pavement being cut. The Piezo sensor needs a cut 11/16" to 13/16" (19mm ± 1mm) wide, 1" (25mm) deep slot cut in the road in a single pass. Although this can be done by cutting two parallel slots and chiseling out the center material, it is highly recommended to do this in a single pass to save time and to ensure greater accuracy of the cut. If a single blade is not available, multiple blades can be put together to form a dado blade. A 3/8" (9mm) and a 1/4" (6mm) blade, with a 1/16" (2mm) spacer between them performs very well. Additional blade widths are necessary for cutting the slots for the tubing for the homerun cables.
- Large capacity air compressor with hose and nozzle - for blowing out the slot and drying the area after the cut.
- Trenching equipment as required for burying the conduit to the control cabinet.
- Power washer or high pressure water hose - for washing out the slot.
- Water - for saw and for washing out the slot
- Broom - Street broom type with stiff bristles for general cleanup.
- Slow speed electric drill with mixing paddle
- Additional mixing blade if a 2 part loop sealant is used. There should not be cross contamination of the grout used for the piezo and the loop sealant material.
- Wire Brush and/or bristle brush - for cleaning out the slot after cutting and during washing.
- 3" or 4" (75-100mm) putty knife for use with the grout
- Small pointed trowel for putting the grout into the slot.
- Wire Strippers. Knife type blade strippers, such as Ideal Tools Stripmasters should be used due to the toughness of the HDPE jacket on the sensor homerun cable.
- Cleaning Materials for hands and equipment. The citrus hand cleaner works well. Include lots of paper towels.
- Angle Grinder with appropriate grinding wheel for smoothing out the grout after the installation.
- Hammer and masonry chisels. May be required for chipping corners, etc.
- Disposable gloves (rubber dishwashing gloves work much better than the latex or plastic gloves)
- 2" (50mm) duct tape. Enough for twice the length of all the sensors. Used to keep excessive grout off the road next to the slot during the installation.
- Plumbers putty or duct seal to form dams at the end of the grout
- Straight edge
- Tape measure - at least 20' (6m) long
- Pavement crayons
- Chalk line
- Pavement paint
- 1/8" (3mm) diameter cord or rope for use in laying out the lines
- Hammer drill and 2" (12mm) concrete bit
- LCR Meter, such as a BK 875A, to check and measure Capacitance and Resistance of the sensors before and after installation.
- Oscilloscope. Although not essential, it is the only instrument that will give a complete verification that the sensors are fully functioning when the installation is complete. If reliable power is not available on the site, a battery operated oscilloscope should be used, such as the Fluke Scopemeter.
- Generator if electrical power is not available on site. Verify the electrical load of the tools being used compared to the capacity of the generator.
- Appropriate traffic control, as required by local regulations and appropriate safety guidelines
- Safety equipment required for workers. Safety helmets, safety glasses, reflective vests, etc, as required.
- Not included in this list are materials required for inductive loops (if used), control cabinets, junction boxes, and other off the road work.

Measurement Specialties Inc, Sensor Products Division, 950 Forge Ave, Norristown, PA 19403 TEL: (610) 650 1580 FAX: (610) 650-1509



Roadtrax BL Traffic Sensors

Revised October 29, 1999

Sensor Testing:

The piezoelectric sensors should be tested prior to and after installation. Because of the high costs of installation compared to the cost of the sensor, it is imperative that the sensors be checked out prior to putting them into the road to determine if any damage has been done to the sensor during shipping and handling. The following tests should be done prior to installation:

Equipment needed: LCR meter, such as a BK Instruments 875A.

1. **Capacitance:** Measure the capacitance of the sensor with the attached lead in cable. This should be within the range as per the product data sheet for that length sensor and passive cable. The meter should typically be set on a 20nF range. The red probe should be connected to the center electrode of the cable and the black probe to the outer braid. Make sure that your hands are not holding across the two connections.
2. **Dissipation Factor:** With the capacitance set on the scale indicated above, switch the meter over to Dissipation Factor. The reading should be less than 0.04.
3. **Resistance:** Measure the resistance across the sensor. The meter should be set on the 20MΩ setting. The meter should read in excess of 20MΩ, which is typically displayed with a '1'.

Testing after installation:

Once the sensor is installed and the grout has cured, retest the sensor according to the instructions above. In addition, it is recommended that an oscilloscope be connected to the sensor and typical waveforms be collected for a truck and a car. These should then be printed out and saved for permanent records. The output of the sensor will depend on the type of the installation, sensor length, cable length and epoxies used for the installation. Typical settings for the scope would be 200 mV/div for a voltage setting and 50 msec/div for a time setting. The trigger should be set at about 50 mV for a positive going signal.

Sensor Maintenance:

Like any piece of equipment, regular maintenance should be done to the piezoelectric sensors in order to maintain them for a long service life. The sensors should be inspected on a biannual basis, and any cracks in the road or in the sensor encapsulation should be filled. A low viscosity loop sealant such as Bondo 606 or a low viscosity epoxy such as Global PX768 should be poured into any cracks, and then squeegeed smooth. Any loose asphaltic material should be wire brushed away prior to pouring the sealant material in the cracks. Be careful not to raise the profile of the sensor. The sensor should be tested for capacitance and resistance, and the results logged in on the data sheet for the sensors.

Quantity of Grout to be Used:

The BL sensor is to be installed in 3/4"x3/4" (19 x 19mm) slot. However, this is difficult to accurately cut, especially in depth. The formula for the purposes of calculating the amount of encapsulation material to be used is as follows:

$$\begin{aligned} & (\text{Length of Sensor \{in inches\} + 12"} * (3/4" * 3/4") * 2 \quad \text{or} \\ & (\text{Length of Sensor \{in millimeters\} + 300mm} * (19\text{mm} * 19\text{mm}) * 2 \end{aligned}$$

This gives a 100% safety factor, in case the slot is slightly deep or long and so that the bottom of the bucket is not being scraped. For planning purposes, 6' (2m) sensors use approximately 2 gallon (1.5 liters) of encapsulation material and 12' (3.5m) sensors use a gallon (3 liters) of material. There are 230 cubic inches in a US gallon. Check with the manufacturer of the encapsulation material for the closest package size. If the resin is sold by weight, divide the weight by the specific gravity (density) to get the volume.

Measurement Specialties Inc, Sensor Products Division, 950 Forge Ave, Norristown, PA 19403 TEL: (610) 650 1580 FAX: (610) 650-1509



Roadtrax BL Traffic Sensors
Revised October 29, 1999

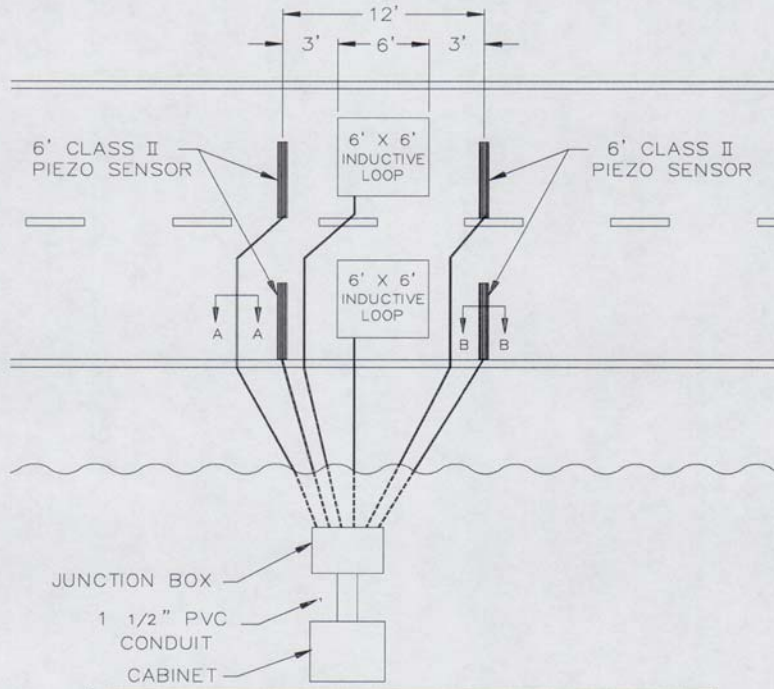

Typical installation layout for a Piezo-Loop-Piezo installation for 6' Class II sensors.

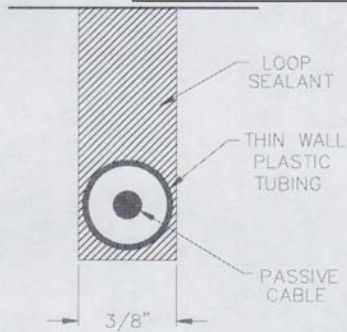

A-A: The passive cable can be put in a thin wall plastic tube for additional protection.

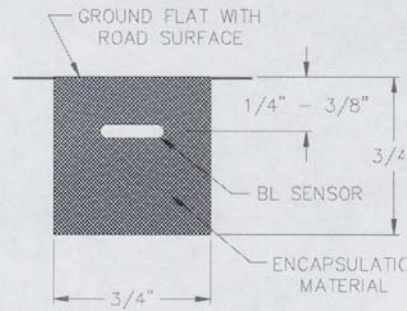

B-B: Typical cross section of a BL Sensor installation.

Measurement Specialties Inc, Sensor Products Division, 950 Forge Ave, Norristown, PA 19403 TEL: (610) 650 1580 FAX: (610) 650-1509



Roadtrax BL Traffic Sensors

Revised October 29, 1999

Frequently Asked Questions:

Approved Grout for installation

Polyurethane

PU 200 (Winter and Summer versions are available)

Global Resins Limited
Unit 6, Corsham
Potley Lane
Corsham, Wilts SN13 9RJ
England
Tel: +44 1225 812201
Fax: +44 1225 812202

Available in the USA through:
International Traffic Corporation
2402 Spring Ridge Dr, Suite E
Spring Grove, IL 60081
Tel: 815 675 1430
Fax: 815 675 1530

Epoxy

E-Bond G-100
E-Bond Epoxies Inc
PO Box 23069
501 N.E. 33rd Street
Fort Lauderdale, FL 33307
Tel: 954 566 6555
Fax: 954 566 6663

Acrylic

ECM P5G
Electronic Control Measurement
Inc
PO Box 888
Manor, TX 78653
Tel: 512 272 4346
Fax: 512 272 4966

AS475
International Road Dynamics
702 43rd Street East
Saskatoon, Saskatchewan
Canada S7K 3T9
Tel: 306 653 6600
Fax: 306 242 5599

Diamond Saw Blades

Texas Diamond Tools
805 Hilbig Rd
Conroe, TX 77301
Tel: 800 346 0646
Tel: 409 756 0646
Fax: 409 756 0687
14x.750x.250x1", PN# 07147507

Bituthane Tape for Temporary installations

Mar Mac Manufacturing Co, Inc
PO Box 278, US Highway One North
McBee, SC 29101
Tel: 843 335 8211
Toll Free: 800 845 6962
Fax: 843 335 8599
Tape ST0005604 (4" wide with a 2" pocket)

BNC Connectors

AMP Incorporated
PO Box 3608
Harrisburg, PA 17111
Tel: 1-800 52AMP52

Also available through Newark Electric and other Distributors
Part Number 227079-5 (BNC with Gold center contact)
Part Number 227079-1 (BNC with Tin-lead center contact)
Hand Crimper - PRO-CRIMPER Hand Tool 58433-1
Stripping Tool 603995-6
Installation Instructions 408-2798
RF Connector Catalog 82074

Measurement Specialties Inc, Sensor Products Division, 950 Forge Ave, Norristown, PA 19403 TEL: (610) 650 1580 FAX: (610) 650-1509



Roadtrax BL Traffic Sensors

Revised October 29, 1999

Installation hints for the MSI BL sensor when using Global Resin PU 200 Resin.

- Cut the slot 3/4" wide and about 1" deep. This will give a bit more room for the grout to flow under the sensor, but will still allow you to install an 11' sensor with one tin of resin. If it is any deeper, you will need a second tin.
- Install the sensor into the road prior to pouring in the resin. Install the sensor so that it is 3/8" below the road surface. This will decrease the output slightly, which will actually make it more compatible with many of the electronics on the market.
- Cut a jig from wood that is "T" shaped, so that you can push the sensor into the road the 3/8". The flange should be about 5/8" wide and 3/8" long.
- Prior to placing the sensor into the road, make sure it is straight and not curved or twisted. It may need to be untwisted slightly. Use a block of wood (1"x2"x6") with a thin slot cut into the side as handles to untwist the sensor.
- Press the brass of the sensor into the slot, and then position it to the correct depth using the depth jig. Do not push down on the brackets.
- Premix the resin for about 2 minutes or until smooth. Use a drywall mixing paddle (for example, Grainger part number 4R539) in a 600 rpm drill. Make sure the resin is homogeneous prior to adding in the hardener.
- When everything is ready, add the hardener, and mix for about 15 - 30 seconds ONLY. Do not overmix, since the pot life is relatively short in warm weather.
- Squeeze in the sides of the can to form a pouring spout, then **IMMEDIATELY** pour the resin into the slot, trying to pour a thin bead on one side of the sensor in the slot. Pour the resin back and forth along the length of the sensor, letting it flow under the sensor as you move along the sensor.
- Fill the slot very slightly overfull, at least on the first sensor until you get some experience.
- As soon as everything looks good, pull off the tape. The resin should still be slightly fluid when you pull off the tape. The resin will flow slightly and should be very close to being flush with the road.
- It is not necessary to trowel the resin into the slot. It will pour, provided that it is not over mixed.
- When the resin is cured, grind the top of the encapsulation flush with the road using an angle grinder.
- Any further comments or hints are greatly appreciated.

Measurement Specialties Inc, Sensor Products Division, 950 Forge Ave, Norristown, PA 19403 TEL: (610) 650 1580 FAX: (610) 650-1509

Typical Cabinet Door Seals

TOP VIEW

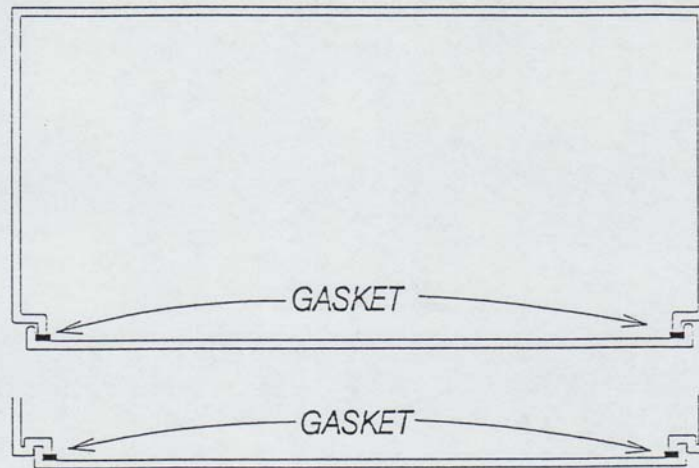

SIDE VIEW

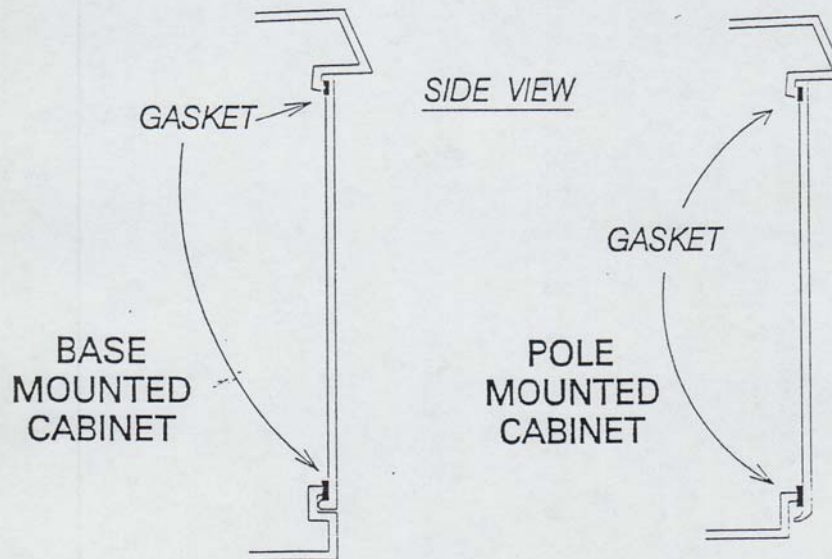

FIGURE 1

Typical and Minimum Cabinet Dimensions

(underside views – mounting brackets)

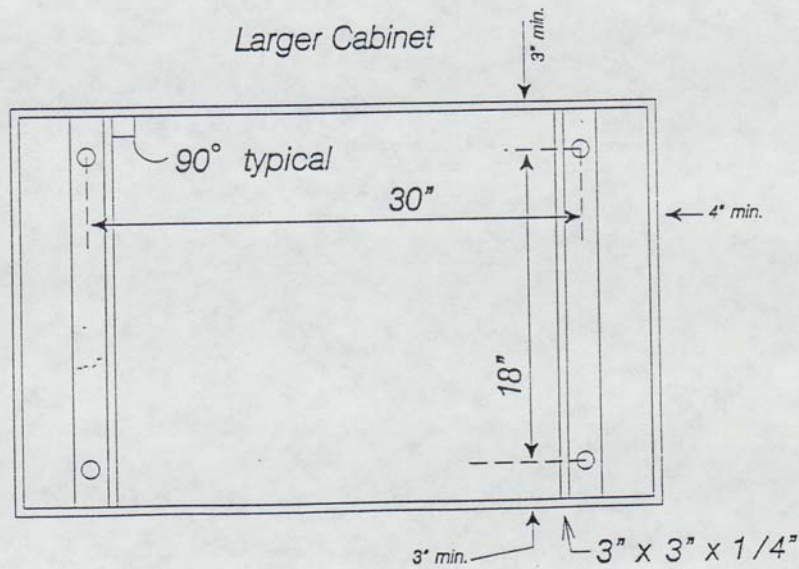
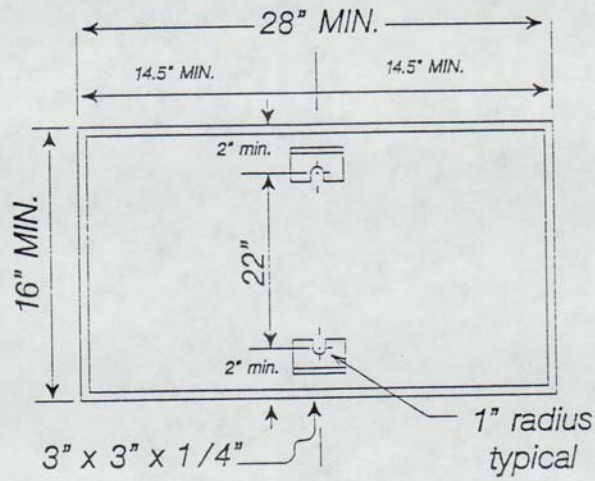

FIGURE 2

Typical Cabinet Detail

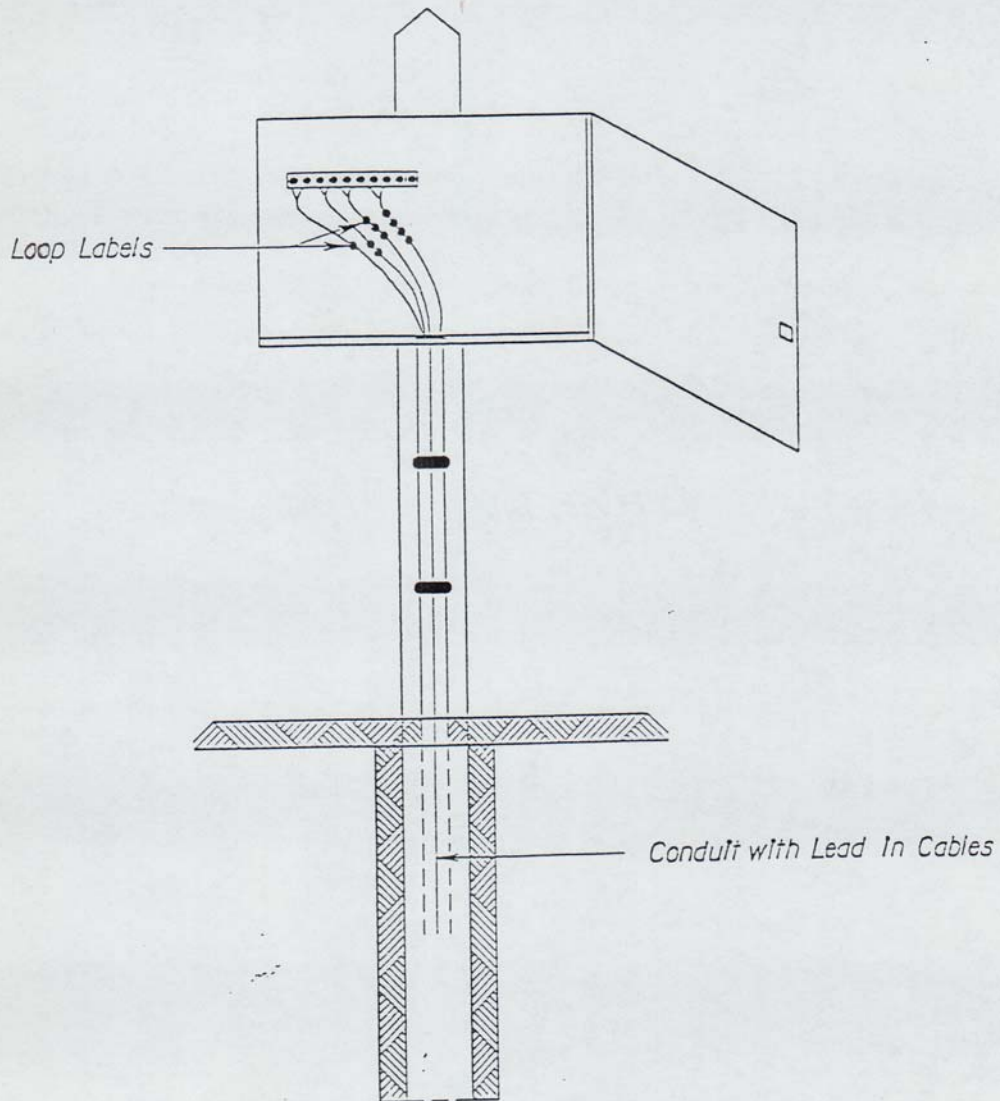

FIGURE 2A

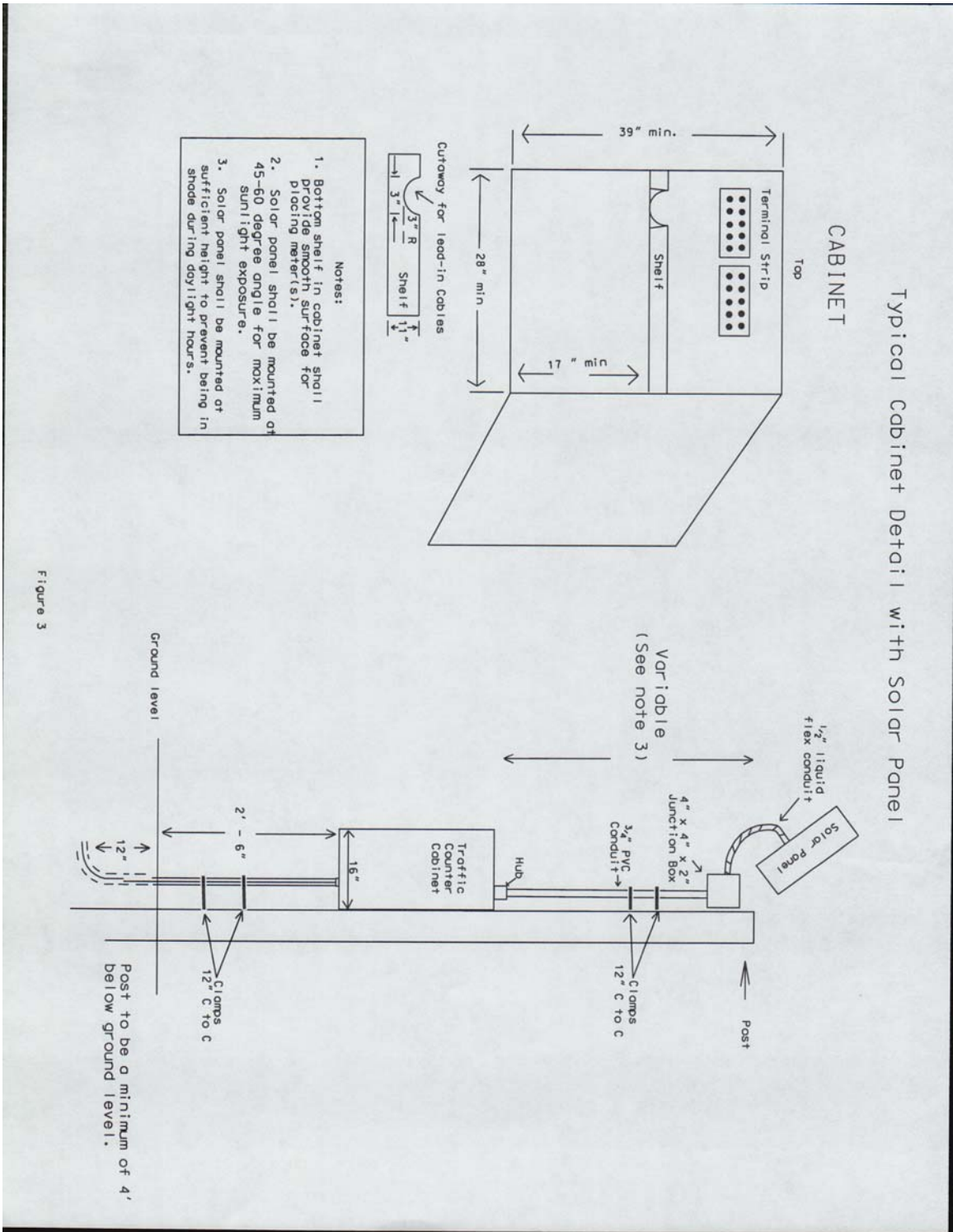

Figure 3



Data Collection

Making the World a Safer Place to Travel™

/// LPM-33E™

Low Power Modem

ALL MODEMS ARE NOT ALIKE!

Commercially available modems are generally not suitable for use in roadside applications. The temptation is strong to use least-cost modems, but Peek and its customers have found out through direct experience that commercial indoor modems, and even "industrial" modems, can have low reliability in field use.

That's why Peek offers the LPM-33, specifically designed to provide data communications in roadside applications requiring remote access via standard dial access telephone service. It is designed to meet the rigors imposed by extreme outdoor data collection and control cabinet environments. It is designed to operate over a temperature range of -40°F to +162°F (-40°C to +72°C).

The LPM-33 can be powered by any source in the range from 5 to 36 Vdc. It features a low power standby mode that allows it to be battery powered. In standby mode, the LPM-33 requires less than 0.5mA of current at 12 Vdc. A solar panel-charged battery provides a fully satisfactory method of powering the LPM-33. Alternatively, the LPM-33 can be powered by a nominal 12 Vac from an available AC to DC wall mount transformer for use with any 120 Vac outlet.

Baud rates up to 33,600 are supported by the LPM-33. It is fully compatible with applicable Bell and CCITT standards, including those for error correction and data compression. The LPM-33 will operate in auto-answer and originate modes.

The LPM-33 uses several timers to reduce net power consumption in typical applications. Sixty seconds after the termination of ringing voltage or 120 seconds after stopping of DTE data the LPM-33 will automatically revert to its low power standby mode. Standby mode will also occur 10 seconds after the loss of carrier is detected. The standby mode of the LPM-33 can be disabled, leaving the modem in continuous active mode.



The LPM-33 is easy to use and install. It comes equipped with an RS-232 serial interface that can be directly connected to the RS-232 port of most traffic recorders and traffic devices. Two RJ-11 jacks allow quick connection to the telephone circuit and a utility phone that can be used while the modem is inactive. Six front panel LEDs provide complete status information. When power is available to the LPM-33, the green "STBY" LED flashes. This indicates the modem is in low power standby mode. The LED will turn off when the modem receives DTE data or auto-answers an incoming call.

The LPM-33 conforms to the industry standard set of AT commands. Two user-defined profiles can be stored in non-volatile memory by connecting the communications port of a PC directly to the RS-232 connector of the LPM-33 and using a communications program such as HyperTerminal®.

The LPM-33 is housed in a rugged aluminum case. In its standard configuration the LPM-33 is placed on a shelf or flat horizontal surface. It is equipped with four non-slip rubber feet.

Traffic Control

Data Collection

Enforcement

Detection

Tolling

Specifications

Characteristic	Description
Modem Standards	CCITT: V.34, V.32 bis, V.32, V.22 bis, V.22, V.21 Bell: 103, 212A
Error Correction.....	MNP 2-4, LAP-M
Data Compression.....	MNP 5, V.42 bis
Command Set.....	Hayes AT—Additional AT commands for data compression, error correction, cellular operation
Interface to DTE	Type: RS-232, DB 25 connector Speed: Auto-detects with AT command, up to 115,200 Baud Signaling: N-8-1
Operation	Speed: Baud rates to 33,600 Type: Auto-answer and originate
Profiles	2, set to factory default, user-definable, stored in non-volatile EEPROM
Mode Control	Standby (normal): Awaiting ringing voltage or DTE data, flashing green LED Standby to Active: Transitions within 6 seconds of ringing voltage or 200 msec of DTE data, LED on steady Answer: After transition to active mode answers call in accordance with 50 register setting for ring delay Disconnect: Loss of carrier, DTR drop or on-hook AT command Active to Standby (selectable link controlled): Active Connection—10 seconds after loss of carrier No Connection—60 seconds after last ring or 120 seconds after last DTE data
LED Indicators	Standby: Green, flashes awaiting call Ringing: Red Send Data: Red Receive Data: Red Carrier Detect: Red Off Hook: Red
Power	Voltage: 5.0 to 36 VDC; 12 VDC typical; wall mount transformer for 120 VAC source - Stancor STA-4112A Consumption: Standby: 0.5mA @ 12 VDC maximum Active: 85 mA @ 12 VDC typical
Dimensions.....	1.9"H x 5.3"W x 8.6"D (49mm x 135mm x 219mm)
Weight	20 oz.
Environmental Range.....	Storage: -40°F to +185°F (-40°C to +85°C) Operating: -40°F to +162°F (-40°C to +72°C) Humidity: 0 to 95% non-condensing

Characteristic	Description
Construction	Housing: Fully enclosed, anodized aluminum; Not intended for direct exposure to weather, precipitation. Suitable for installation in standard traffic control or traffic data collection field cabinets. Removable screws allow inside access. Electrical: Single printed circuit board inside housing conformally coated for protection
Mounting	Cabinet, shelf or desktop, Rubber feet for shelf/desktop
Controls	Internal: Jumper JP1 disables standby operation if jumper is on External: All operational control is via RS-232 connector
Connectors.....	DTE: DB-25 Female, configured as RS-232, DCE Pin 1: Protective Ground Pin 2: Send Data Pin 3: Receive Data Pin 4: Request to Send Pin 5: Clear to Send Pin 6: Data Set Ready Pin 7: Signal Ground Pin 8: Carrier Detect Pin 20: Data Terminal Ready Pin 22: Ring In Power: Standard 3.5mm recessed jack, female, center positive Telephone: Dual female RJ-11, wired in parallel, phone & line
Line Protection	Standard internal gas tube arrester, 230 Vdc across tip and ring to ground External telco or user-provided protection against surges and high voltage is recommended
Regulatory	Designed to meet applicable FCC standards.

This specification describes the physical and functional properties of the Peek LPM-33E low-power, field modem manufactured by Peek Traffic Corporation. Peek reserves the right to alter any of the Company's products or published technical data relating thereto at any time without notice.

Two-Year Limited Warranty

Peek Traffic Corporation warrants this product against manufacturing defects in materials and workmanship for two years from the date of shipment from Peek. Specific contracts and regional laws may vary or alter these terms.

Making the World a Safer Place to Travel™

<http://www.peek-traffic.com>

Please contact Peek Traffic Corporation for customer inquiries about any of the company's Traffic Control, Data Collection, Enforcement, Detection, or Tolling products. To learn how Peek Traffic is making the world a safer place to travel, visit the Peek Traffic web site at <http://www.peek-traffic.com>.

The information contained in this publication is presented for informational purposes only, and while every effort has been made to ensure its accuracy, the information is not to be construed as warranties or guarantees, express or implied, regarding the products or services described herein or their use or applicability. No license is granted by implication or otherwise to any of Peek Traffic's intellectual property. Peek Traffic reserves the right to alter or revise any of its products or published technical data relating thereto at any time without notice.

Copyright © 2004 Peek Traffic Corporation, A Quixote Company. All rights reserved. Printed in the United States.

Peek Traffic Corporation
A Quixote Company
2511 Corporate Way
Palmetto, Florida 34221
phone: (941) 845-1200
toll free in the US: 1 (866) 260-7335
fax: 1 (941) 365-0837

96-123-3

Automatic Data Recorder Assembly

Cabinet Assembly includes:

- Type IV Base or Pole Mounted Aluminum Traffic Cabinet
- Built to Specification
- Lightning Suppression for:
 - Loop Assemblies
 - Piezos
 - Solar Panel
- Solar Power Charger / Regulator
- Telephone Jack
- Clearly marked terminal facilities



65 Watt Solar Panel

Solar Power Assembly includes:

- 65 Watt solar panel and side of pole or top mounting brackets
- Sealed rechargeable 12 volt, 100 amp hr. battery
- Solar Power / Modem cable

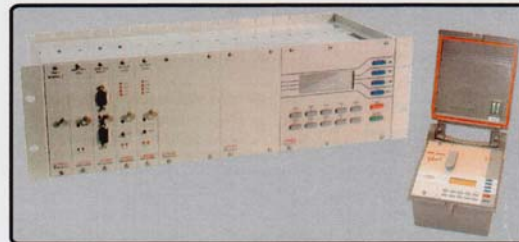
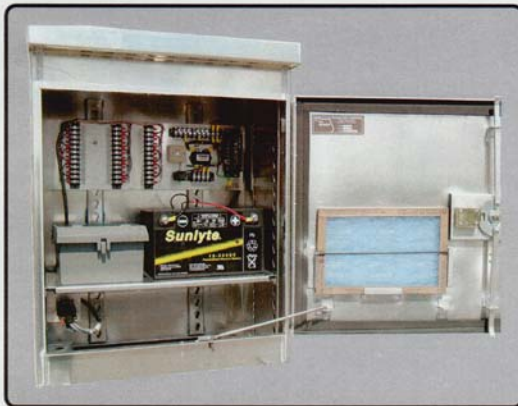

**PEEK
ADR 2000 / 3000**

PEEK LPM 33

Low Power Modem

- Designed specifically for use with ADR 2000 / 3000 Counters / Classifiers
- Designed for extended environmental range
- AC / DC / Solar compatible

ADR 2000 / 3000

- Simple to setup and operate
- Multi-lane operation
- Sensor options
 - Loops
 - Piezos
- Weigh-In-Motion Expandable
- Optional PCMCIA Memory Card
- Optional Keypad and Display
- GPS coordinates



TRANSPORTATION CONTROL SYSTEMS

1030 South 86th Street Tampa, Florida 33619
Tel. 813-630-2800 Fax. 813-630-2801

FIGURE 18

**SPECIFICATIONS
AUTOMATIC TRAFFIC DATA RECORDER
(VOLUME, CLASSIFICATION, SPEED)**

<p>HOUSING Weatherproof cast aluminum with tamper proof latch and hinge with lock</p> <p>WEIGHT Not to exceed 20 pounds</p> <p>INPUT CAPABILITY a. Sixteen (16) internal loop detectors b. Eight (8) internal piezo detectors c. Four (4) Road tube air switches</p> <p>POWER Rechargeable sealed lead gel 6v/10 ampere hour internal battery</p> <p>OPERATING TEMPERATURE -40 F to +158 F</p> <p>MEMORY 128 K bytes expandable to 64 M bytes</p> <p>DISPLAY 80 character LCD</p> <p>KEYBOARD 16 key</p> <p>BAUD RATE up to 33,600</p>	<p>SETUP FEATURES (minimum) a. Date and Time b. Station no. (12 digits) c. I. D. no. (12 digits) d. Number of lanes e. Lane layout f. Sensor distance g. Storage format h. Printout format i. Speed categories (no. & range) j. Classification (15 categories, 1st 13 FHWA type F, user programmable) k. Recording Intervals 1. One PRIME (1-1440 minutes) 2. Four separate PEAK periods l. Start-Stop times (PRIME and PEAK recording intervals) m. Baud rate n. Parity selection o. Data bits p. Reprogram completely from keyboard, computer on-site, and remotely via telemetry</p> <p>OTHER 1. Battery charger 2. Battery tester 3. Data Module or PCMCIA memory card 4. Maintenance and operations manual 5. Real time clock</p>
---	--

Data recovery by data module or memory card, printer, computer at site and by telemetry.

Programs for volume counting, vehicle type classification, speed classification, length classification, and headway / gap classification must be compatible with existing Peek TDP programming data collection systems.

Necessary hardware to connect recorders to road sensors, solar panels and communication modem.

Self contained units, requiring no peripheral devices such as programmers to setup programs.

Main unit power source (battery) can be completely disconnected without loss of recorded data. Recharging of the battery shall be possible without removing the battery from the data recorder.

Store data in memory in a three dimensional matrix form, such as: lane x speed x gap, or vehicle axle classification x vehicle speed x lane.

Real time interrogation of status or program parameters without affecting operation. Setup and configuration to be "user friendly", capable of being done or changed by non-technical personnel.

Recorder shall be capable of using a loop-axle-loop sensor array in each lane for classification.

One (1) year warranty on parts and labor, and one (1) year free replacement on system updates and initial operations training.

FIGURE 18A

Typical Slot Installation

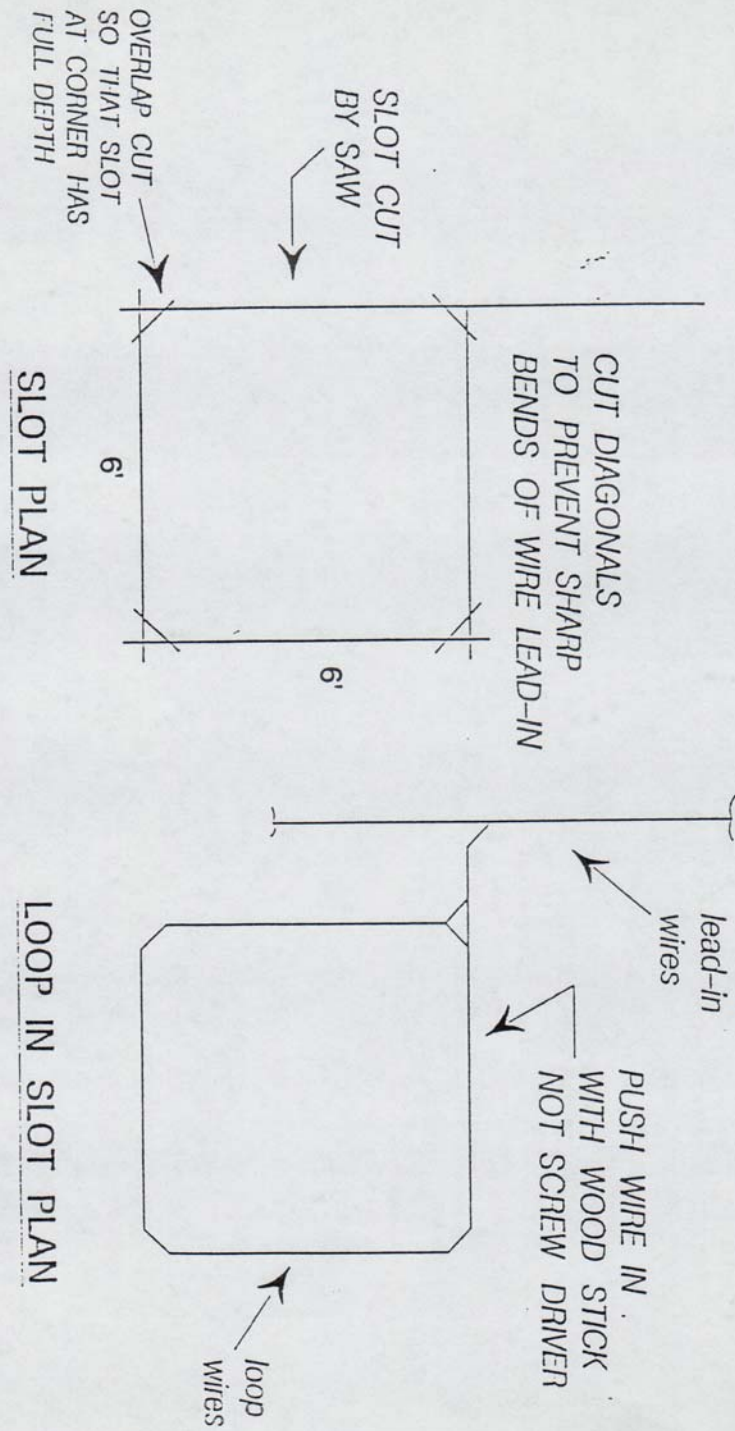

LOOP INSTALLATION IN EXISTING ROADWAYS

FIGURE 4

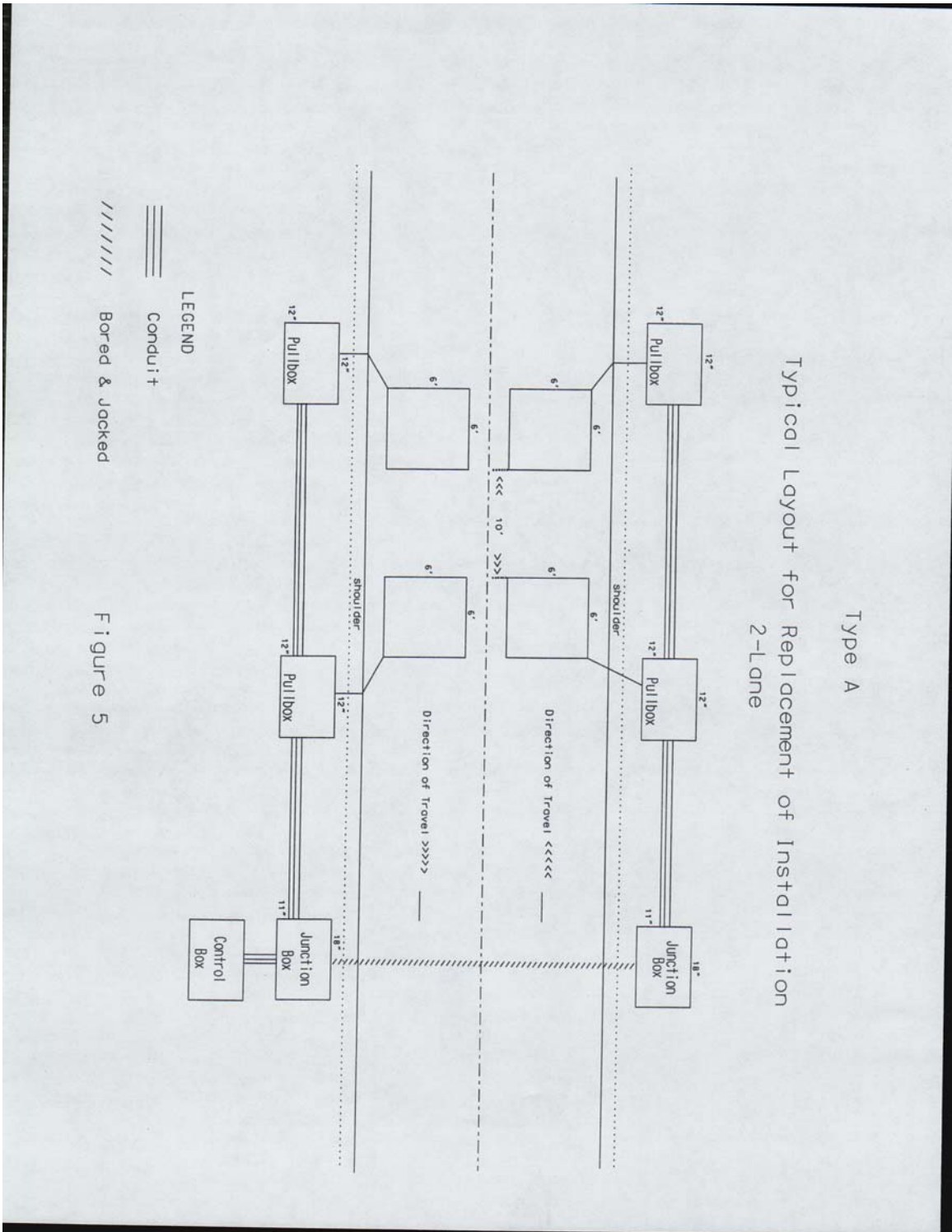

TYPE A TYPICAL LAYOUT FOR NEW 6-LANE INSTALLATION

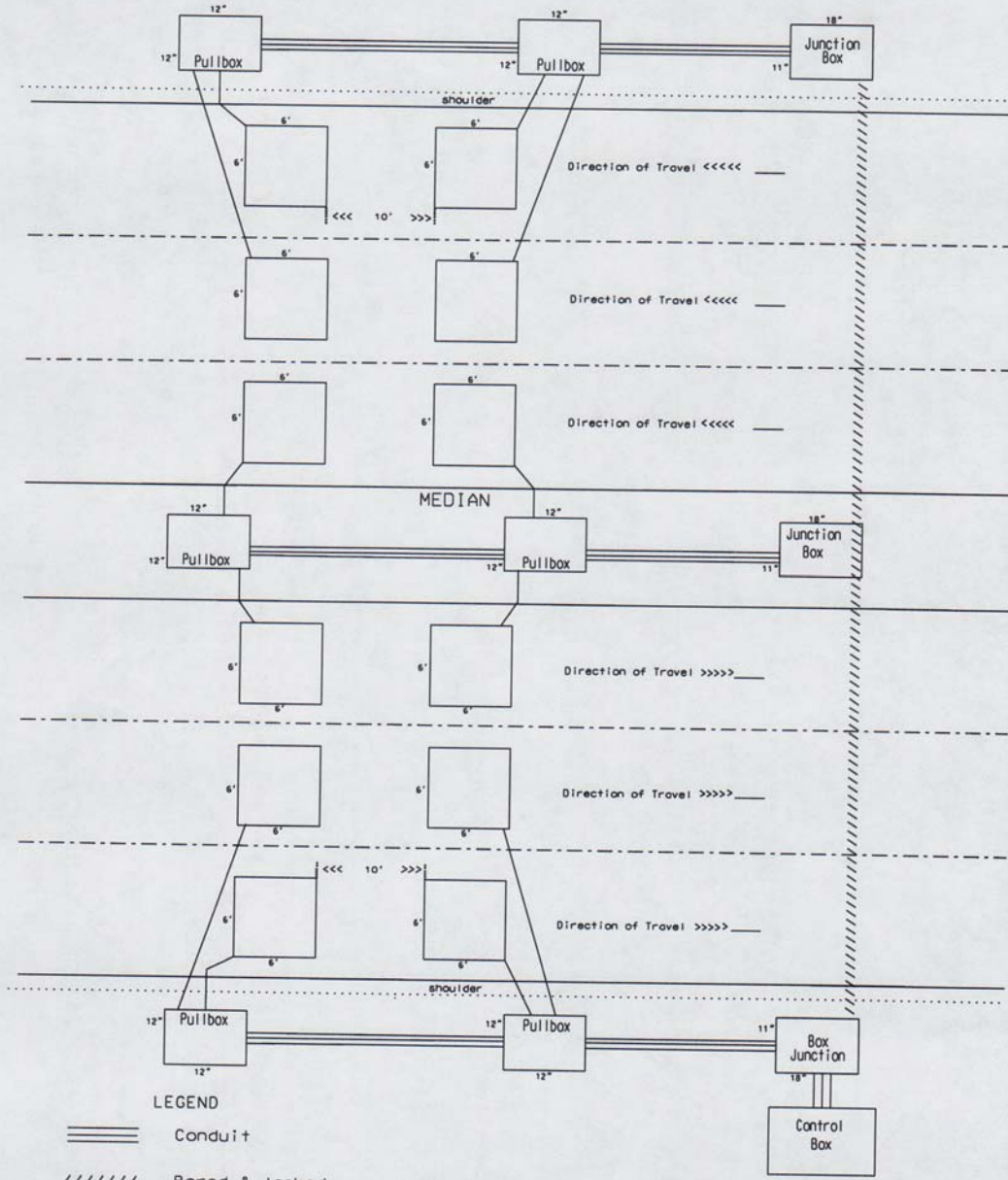

FIGURE 5B

Type A
 Typical Layout for New Installation
 6-Lane / No Median

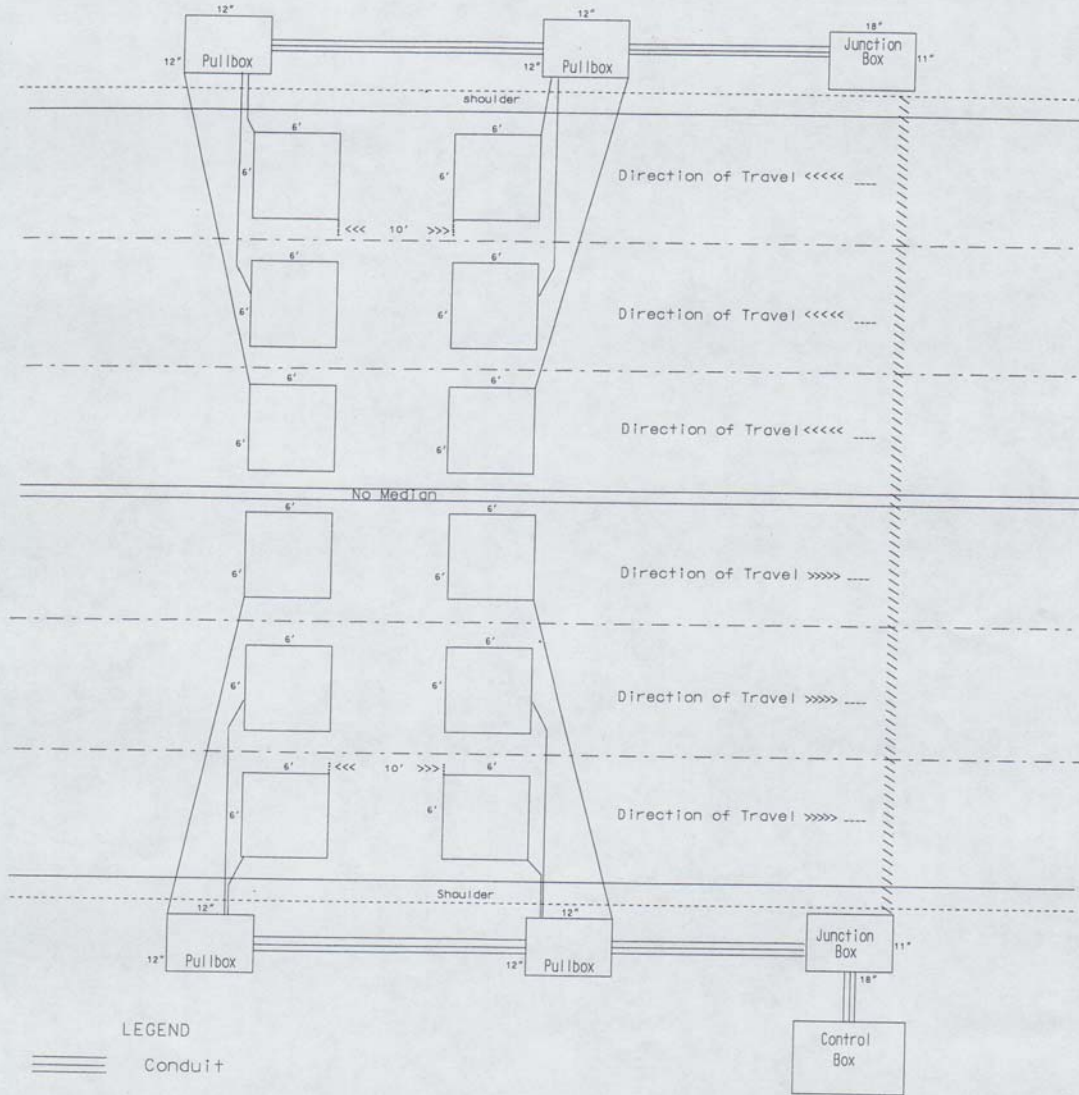
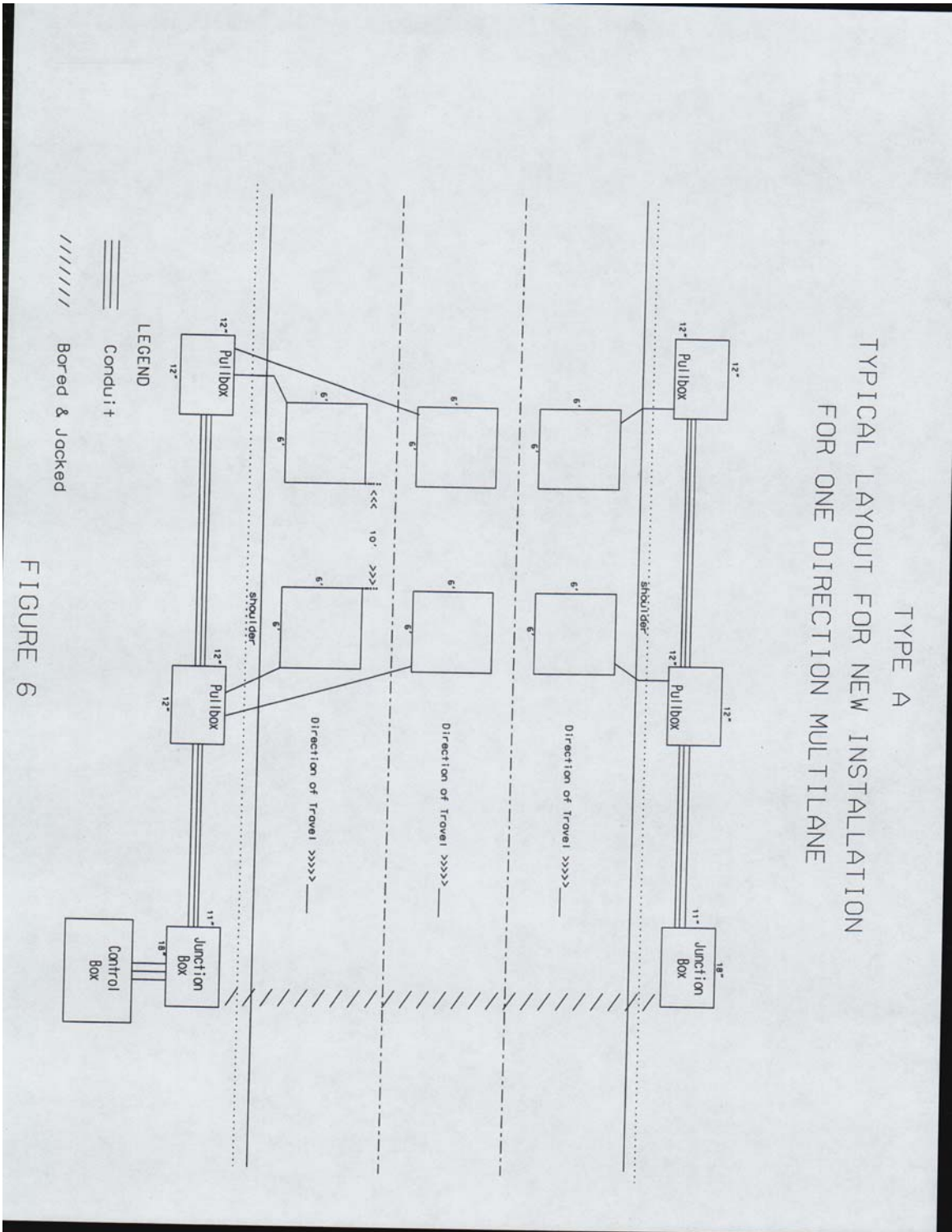

Figure 5C



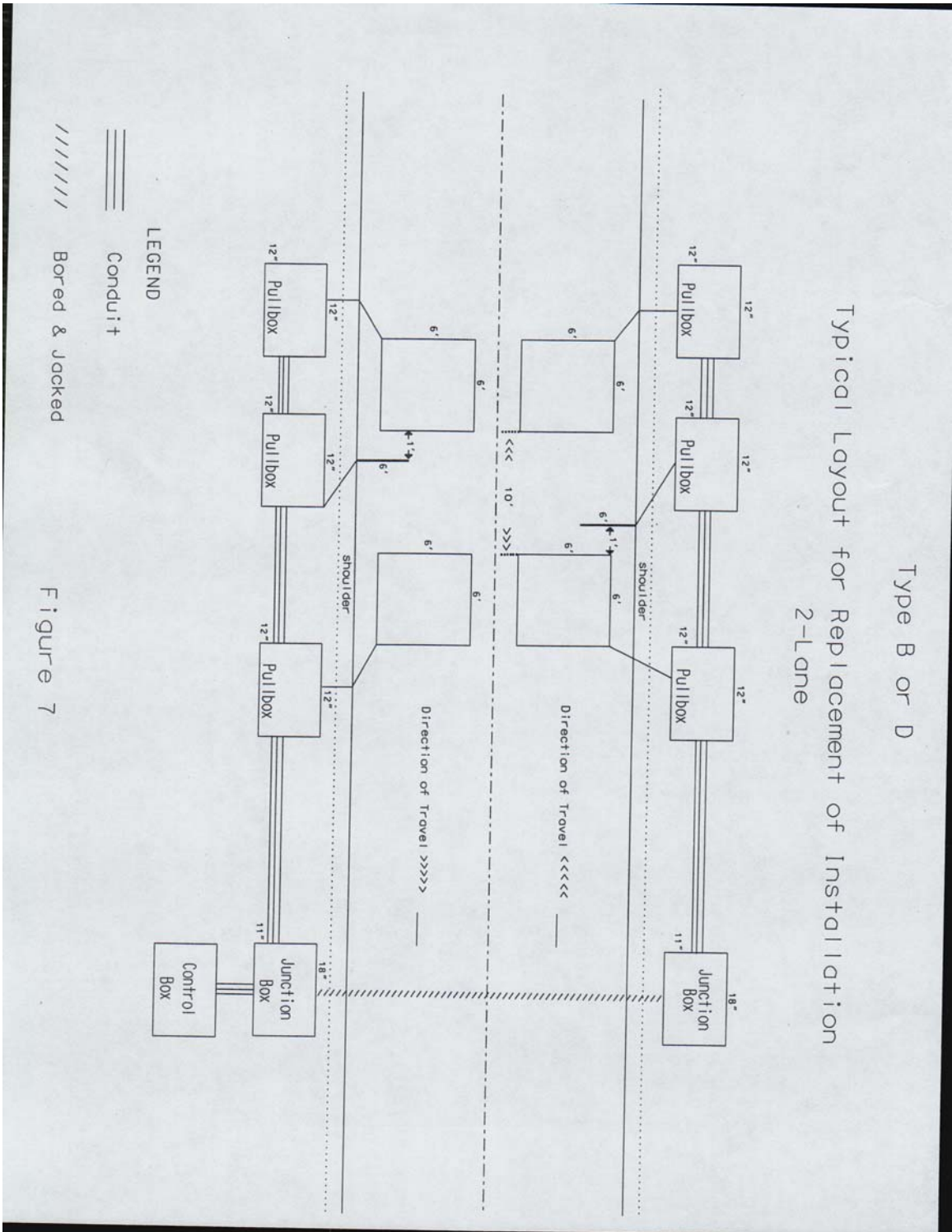
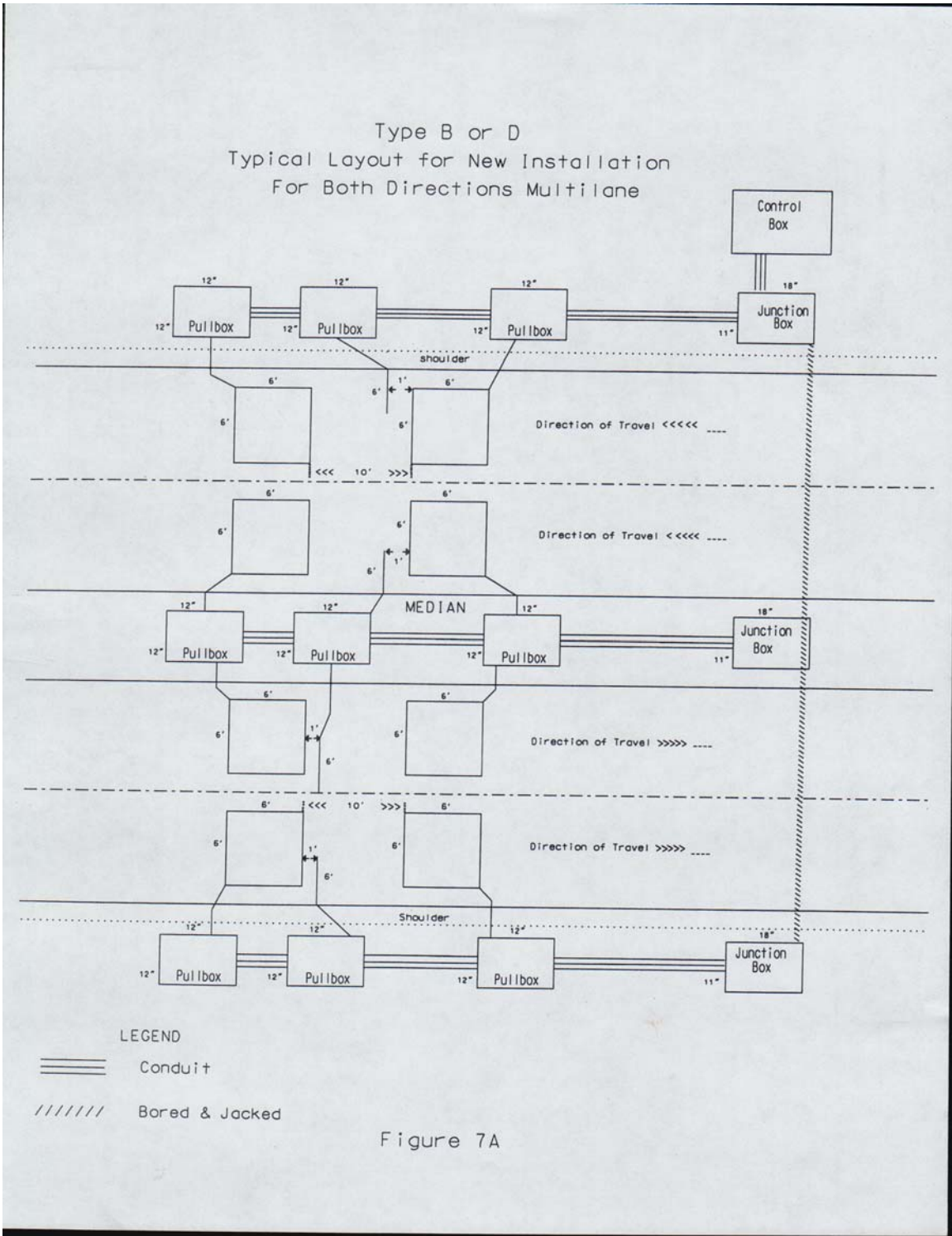

Figure 7



TYPE B OR D
TYPICAL LAYOUT FOR NEW 6-LANE INSTALLATION

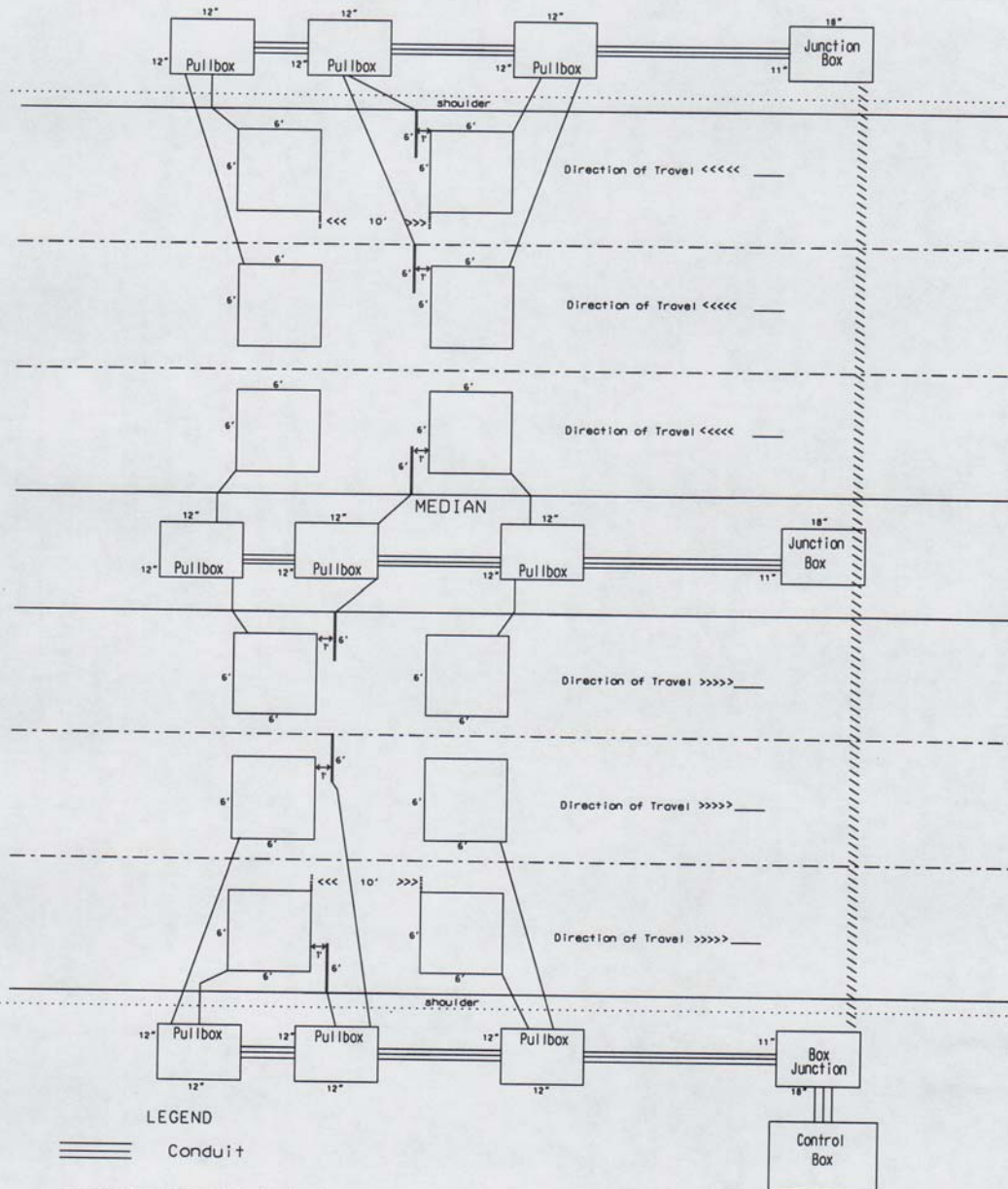
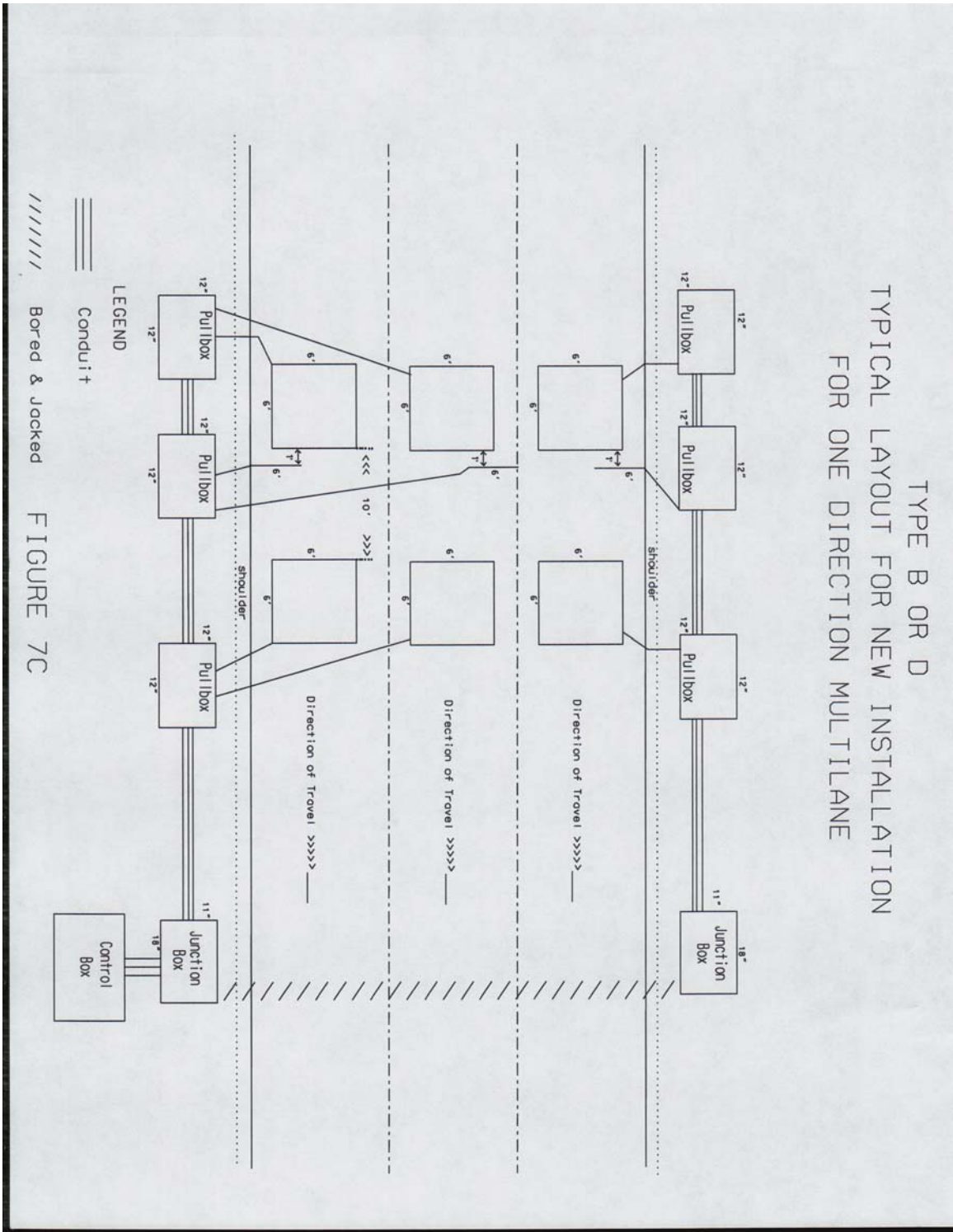
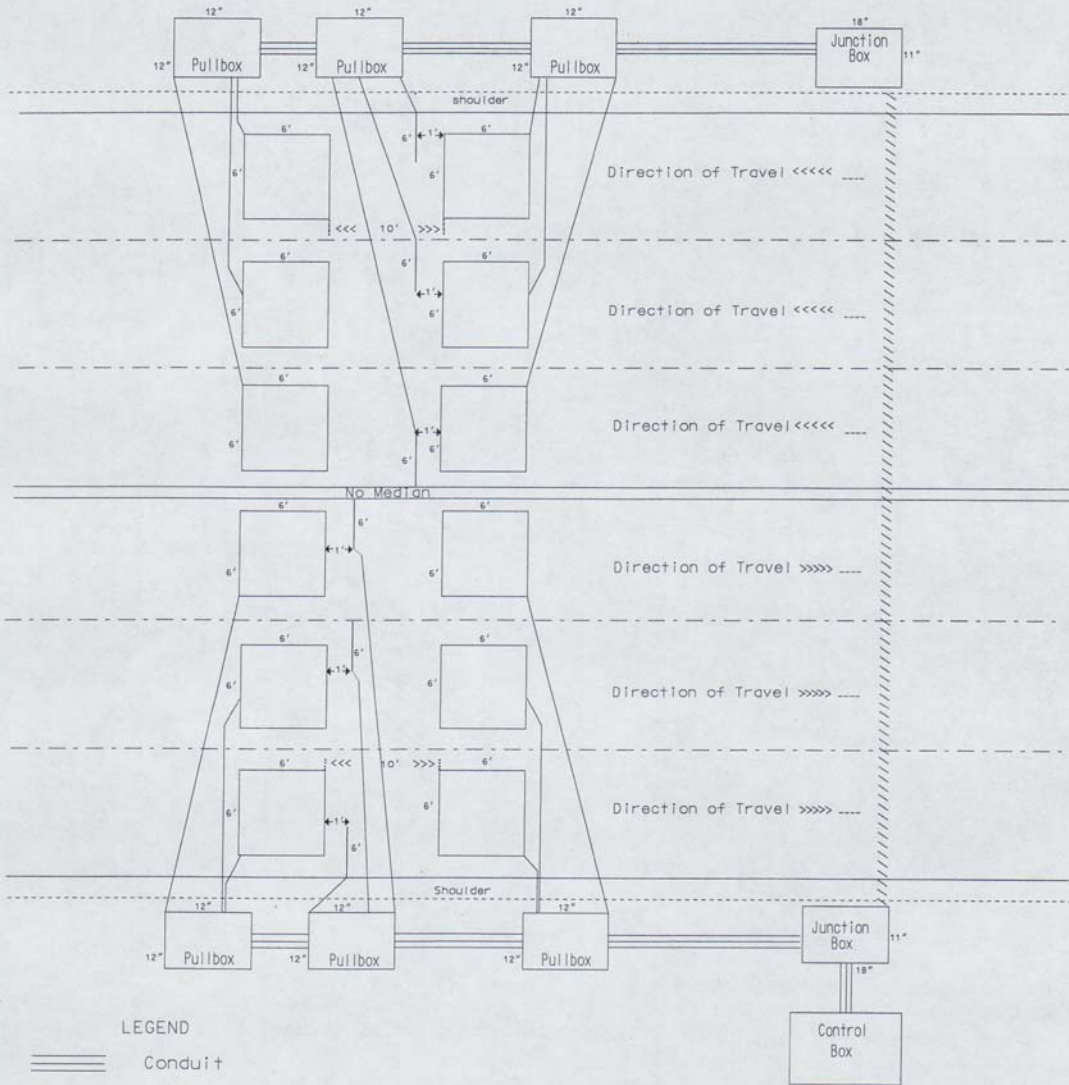

FIGURE 7B



Type B or D
 Typical Layout for New Installation
 6-Lane / No Median



LEGEND

- ==== Conduit
- ///// Bored & Jacked

Figure 7D

Type B or D
 Typical Layout for New Installation
 For Both Directions Multilane

WIM

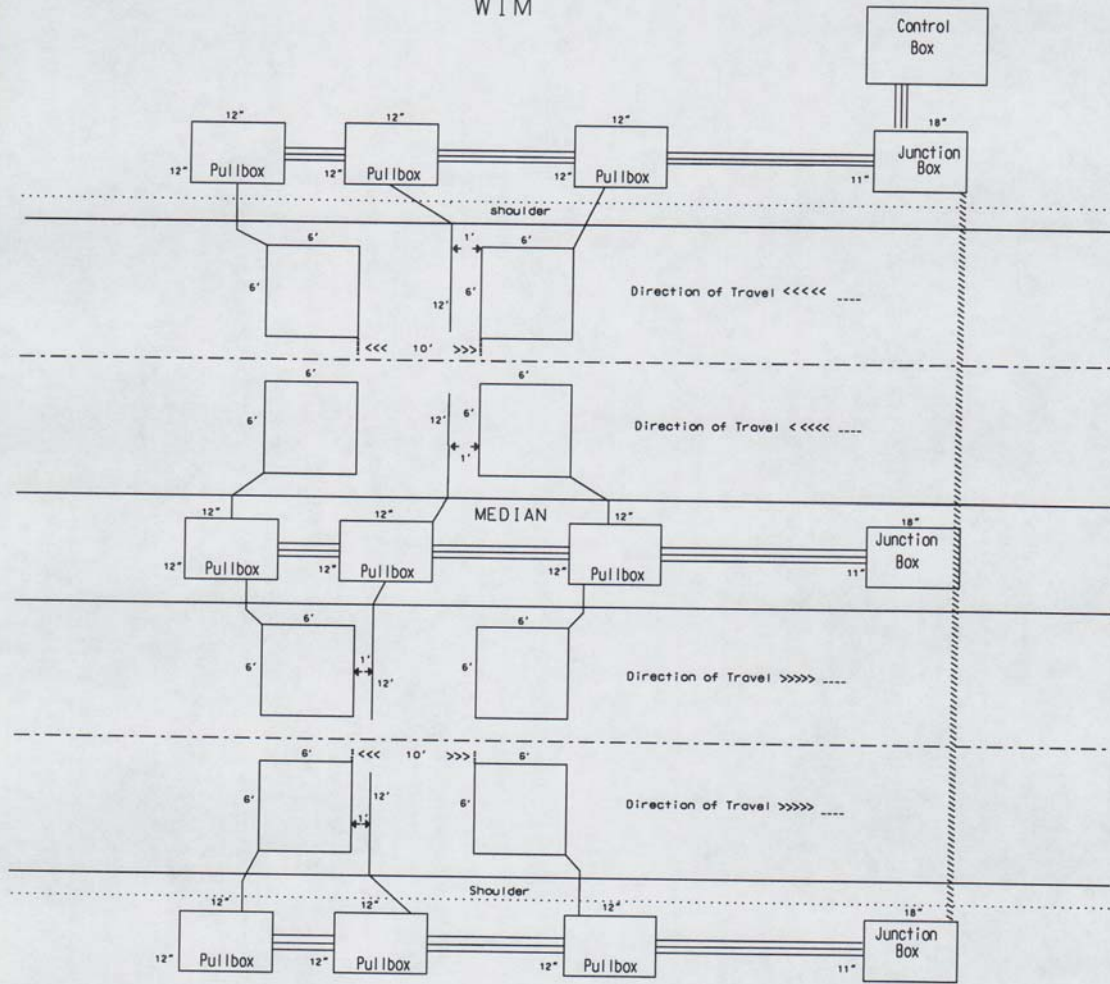

LEGEND

- ==== Conduit
- ///// Bored & Jacked

Figure 7E

TYPE B OR D
TYPICAL LAYOUT FOR NEW INSTALLATION
FOR ONE DIRECTION MULTILANE
WIM

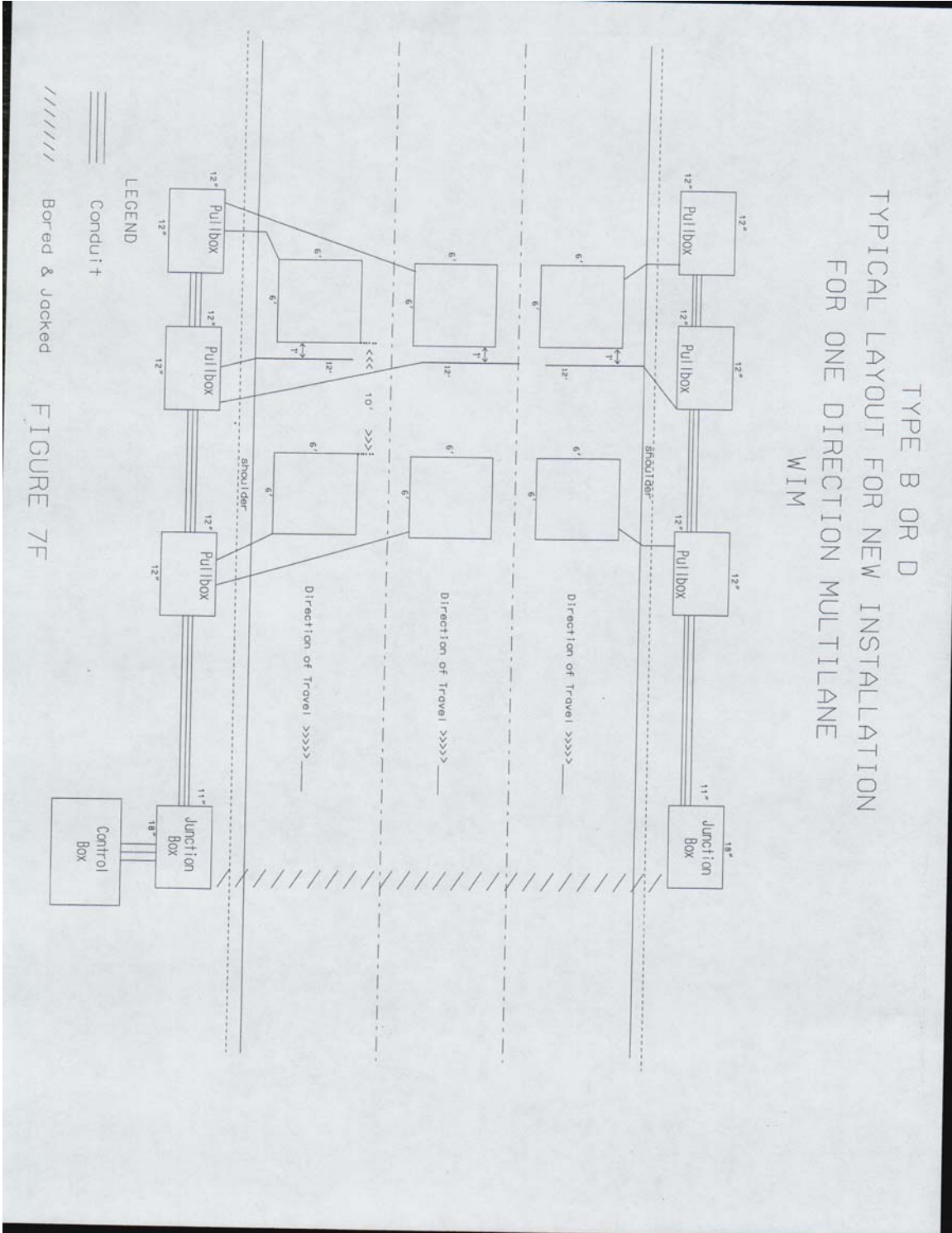

TYPE B OR D
 TYPICAL LAYOUT FOR NEW 6-LANE INSTALLATION
 FOR BOTH DIRECTIONS
 WIM

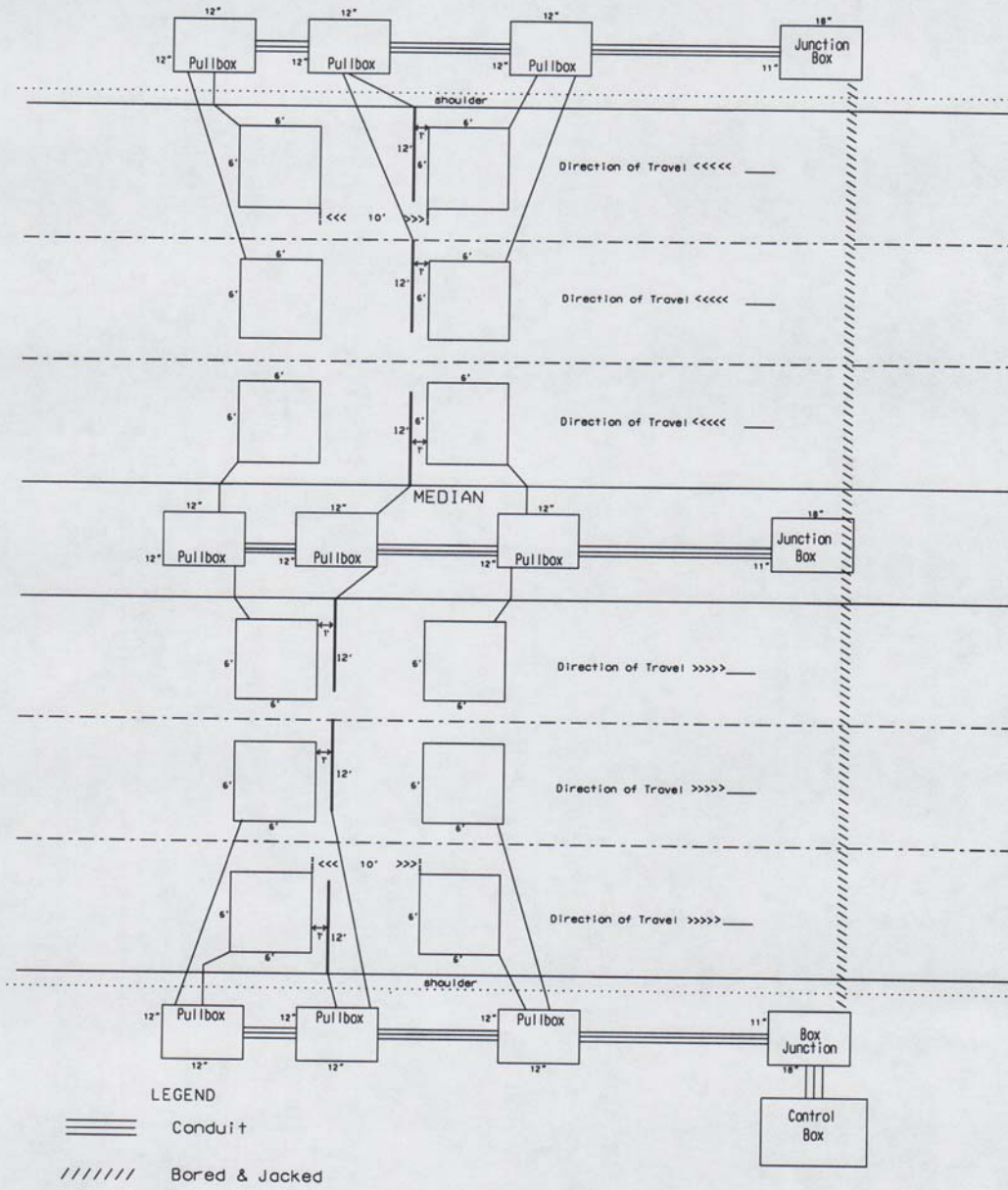

FIGURE 7G

Type B or D
 Typical Layout for New Installation
 6-Lane / No Median

WIM

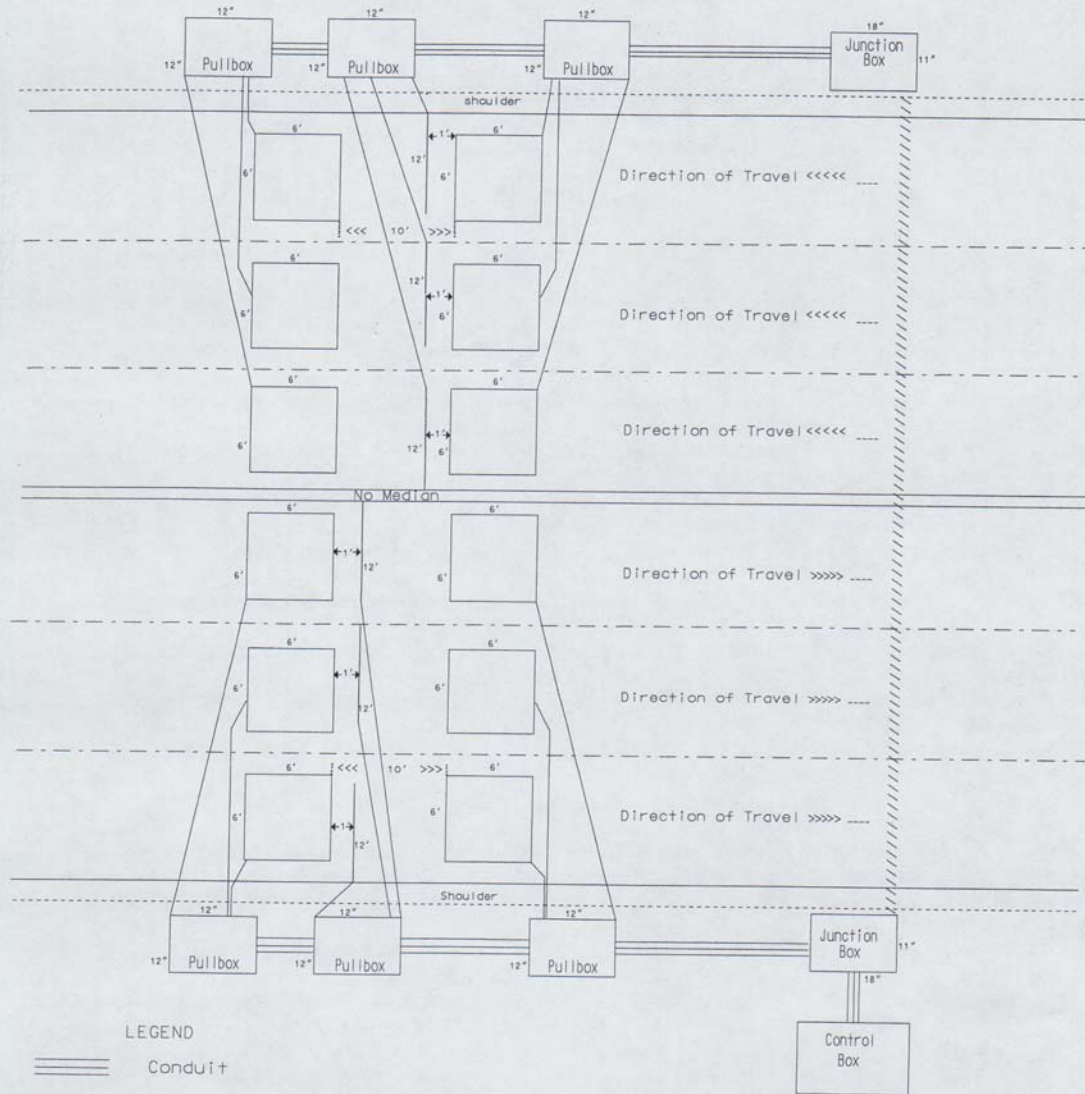

Figure 7H

Loop Wiring

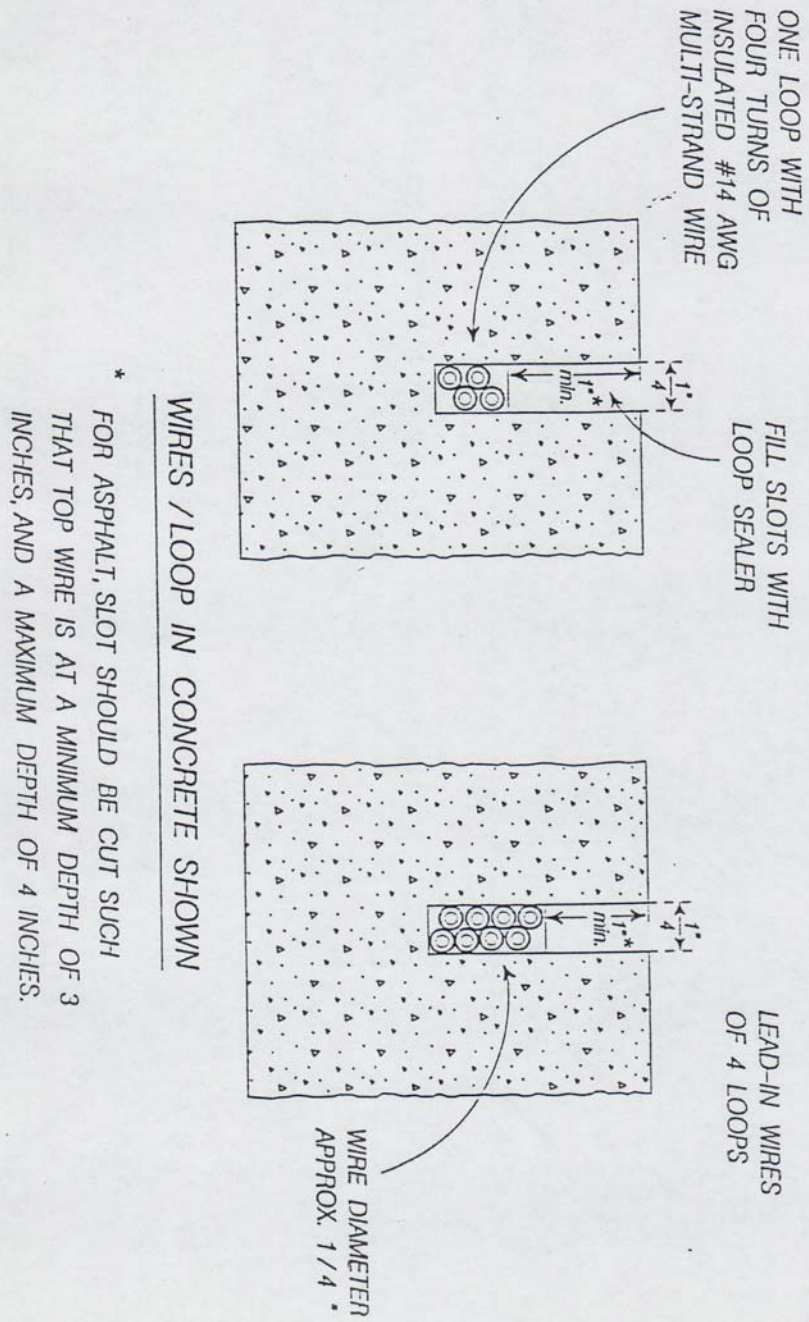

FIGURE 8

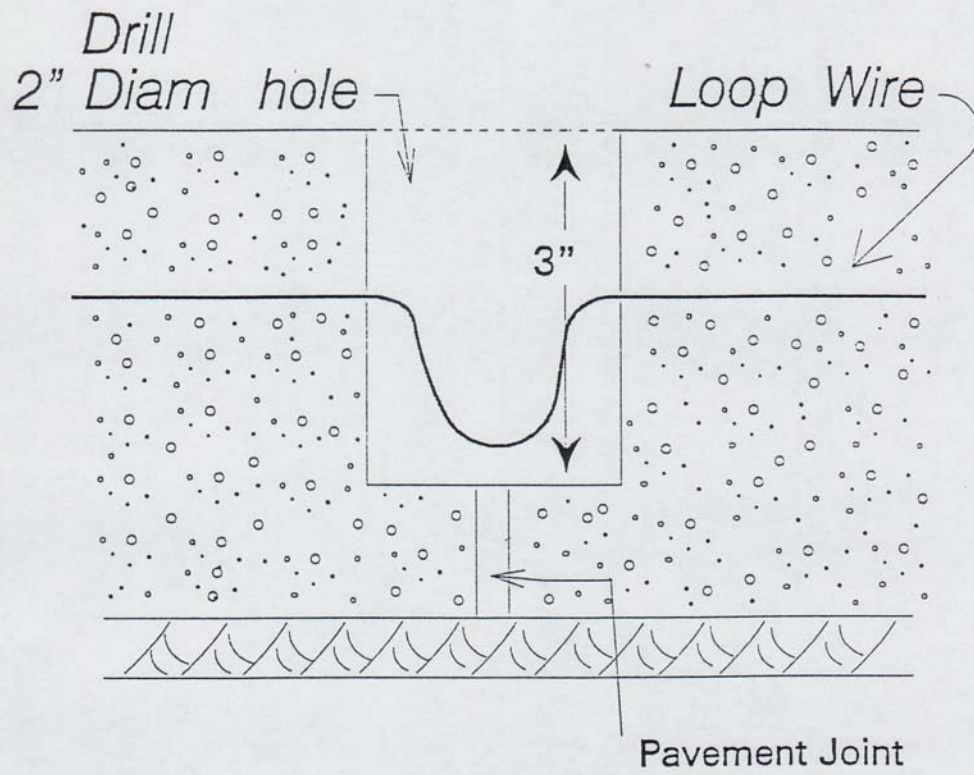

FIGURE 9

Proper Methods of Twisting Wire

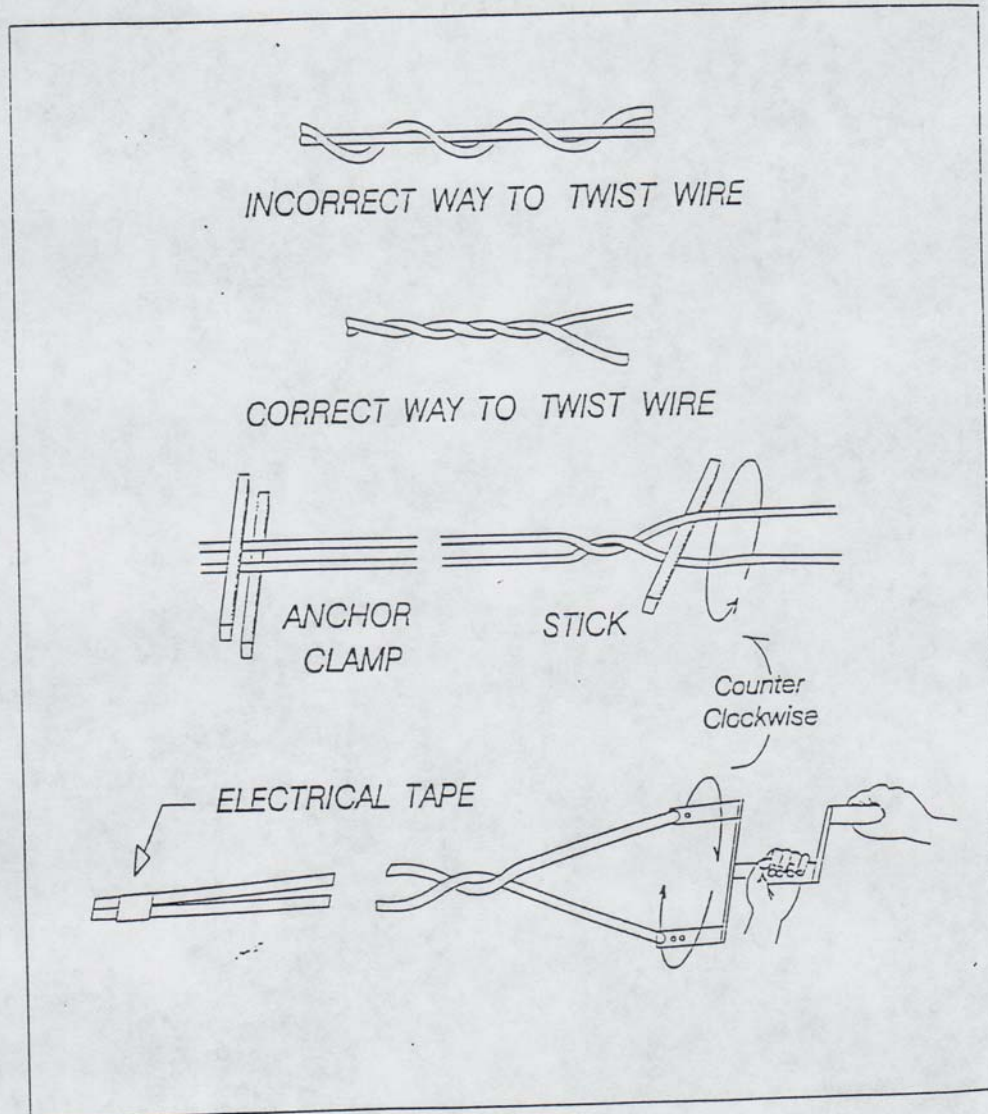

FIGURE 10

Pavement To Earth Conduit Transition Detail

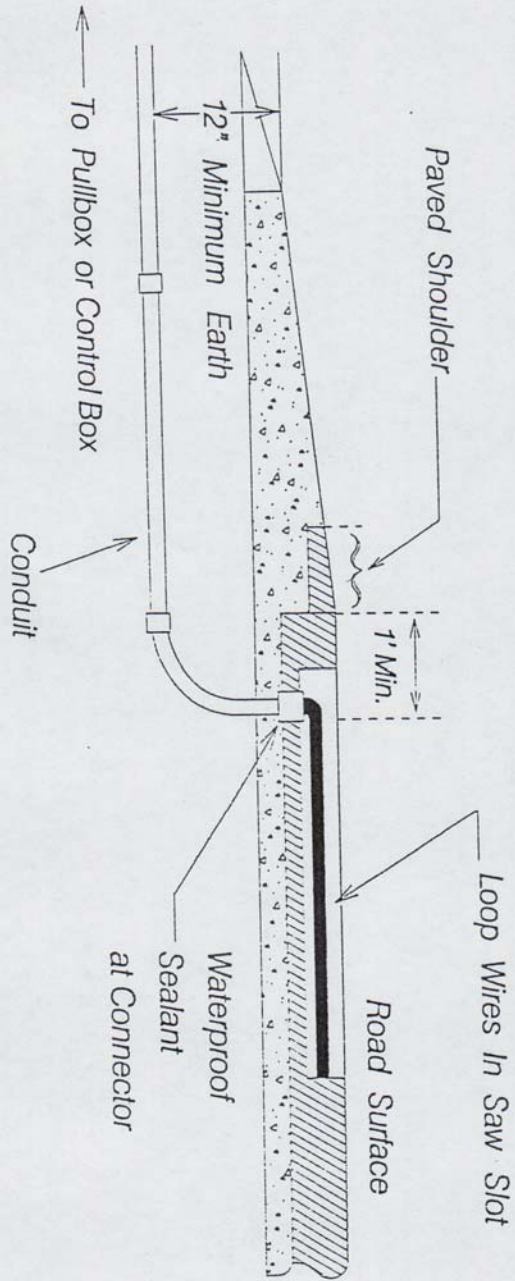

FIGURE 11

Pullbox Installation

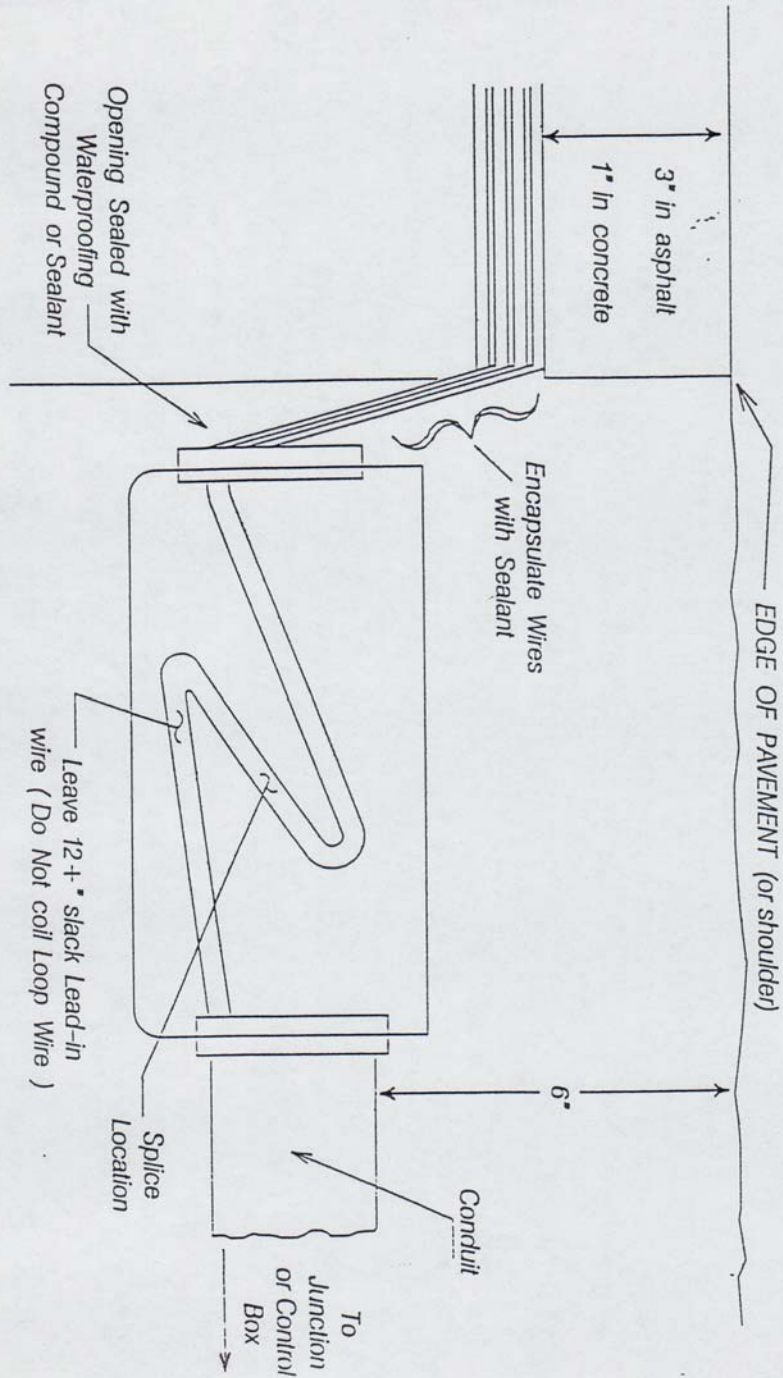

FIGURE 12

Typical Details Grounding Requirements

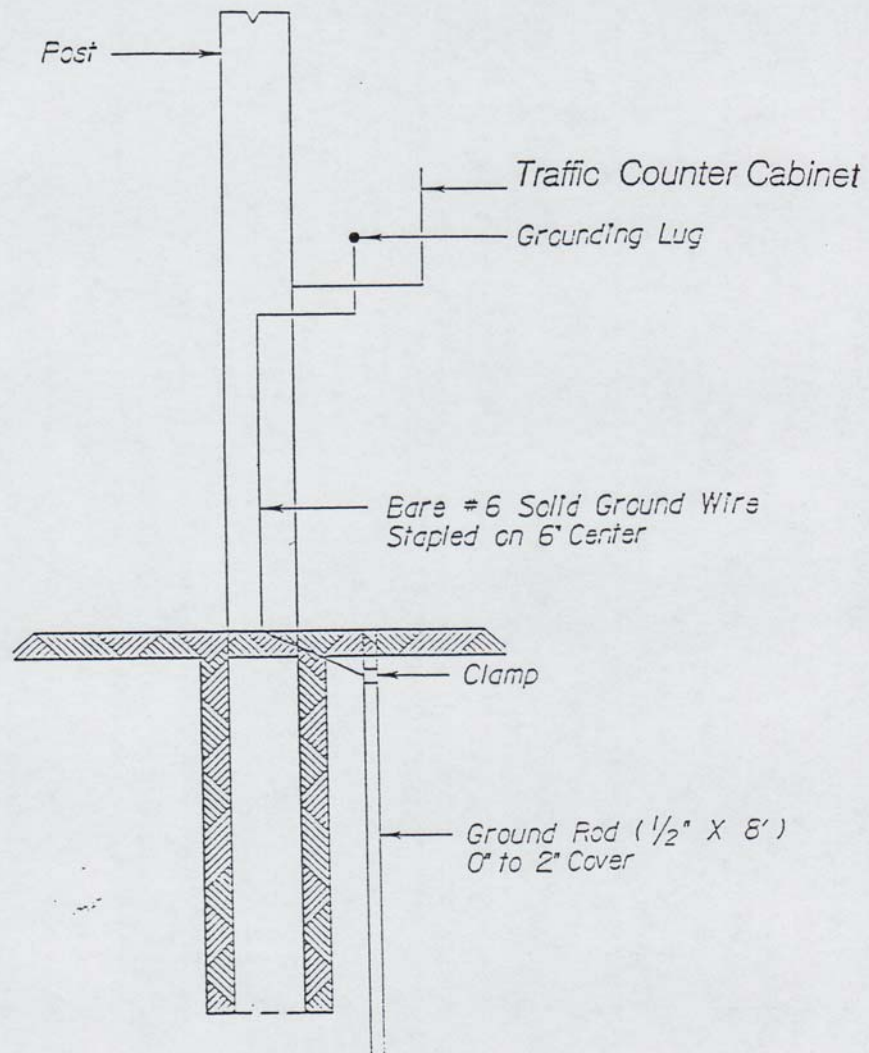
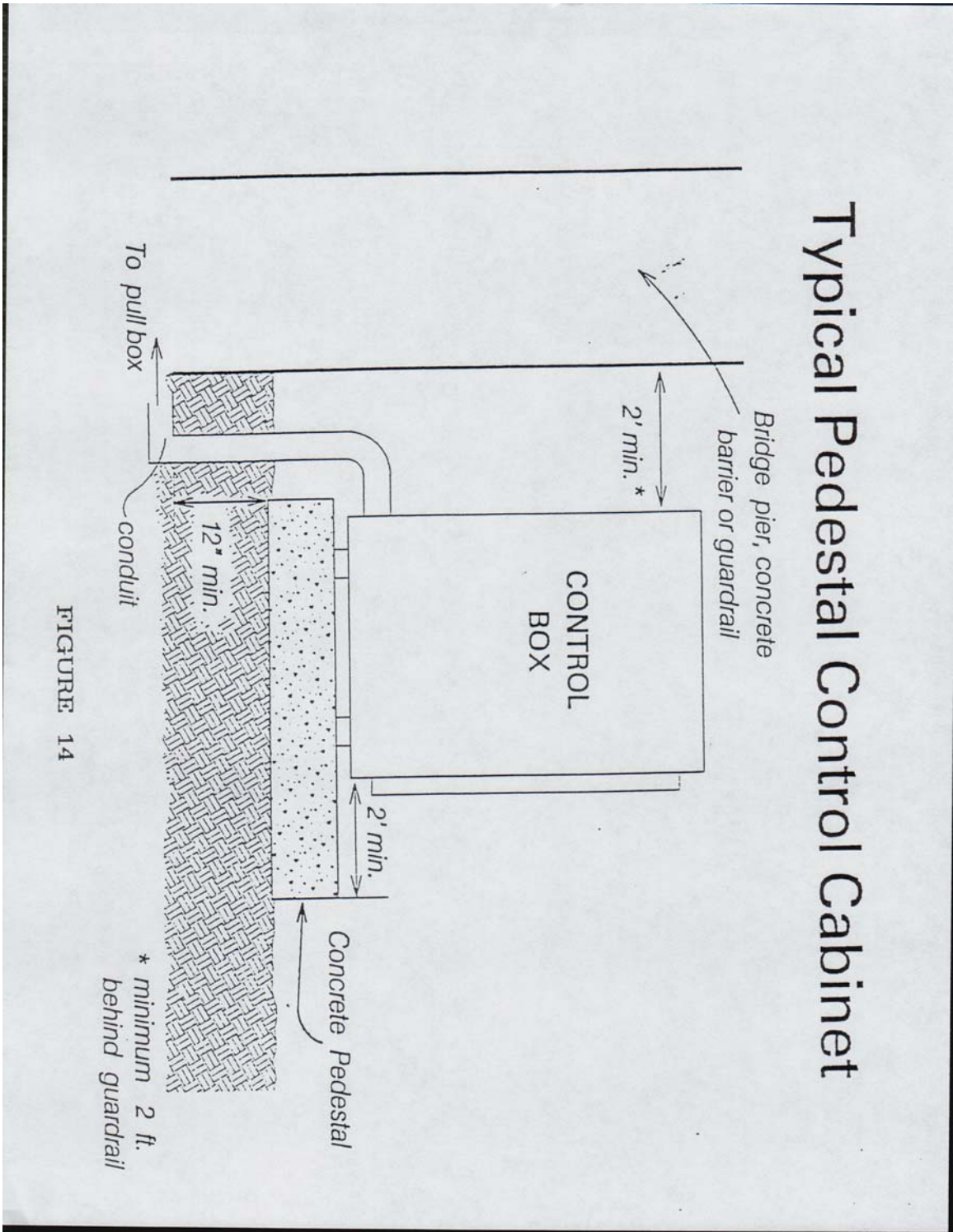

FIGURE 13



Typical Control Box Wiring One Loop Per Lane

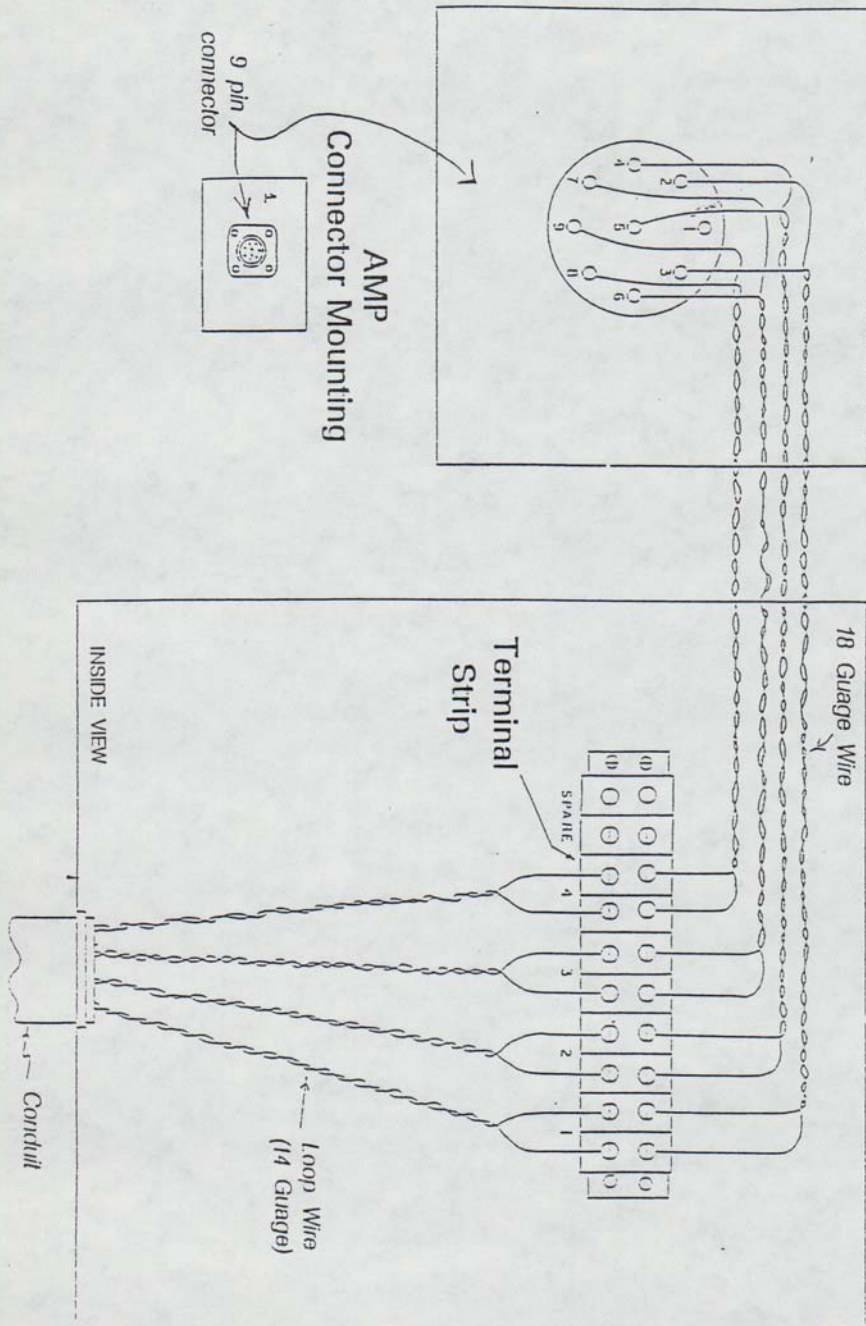
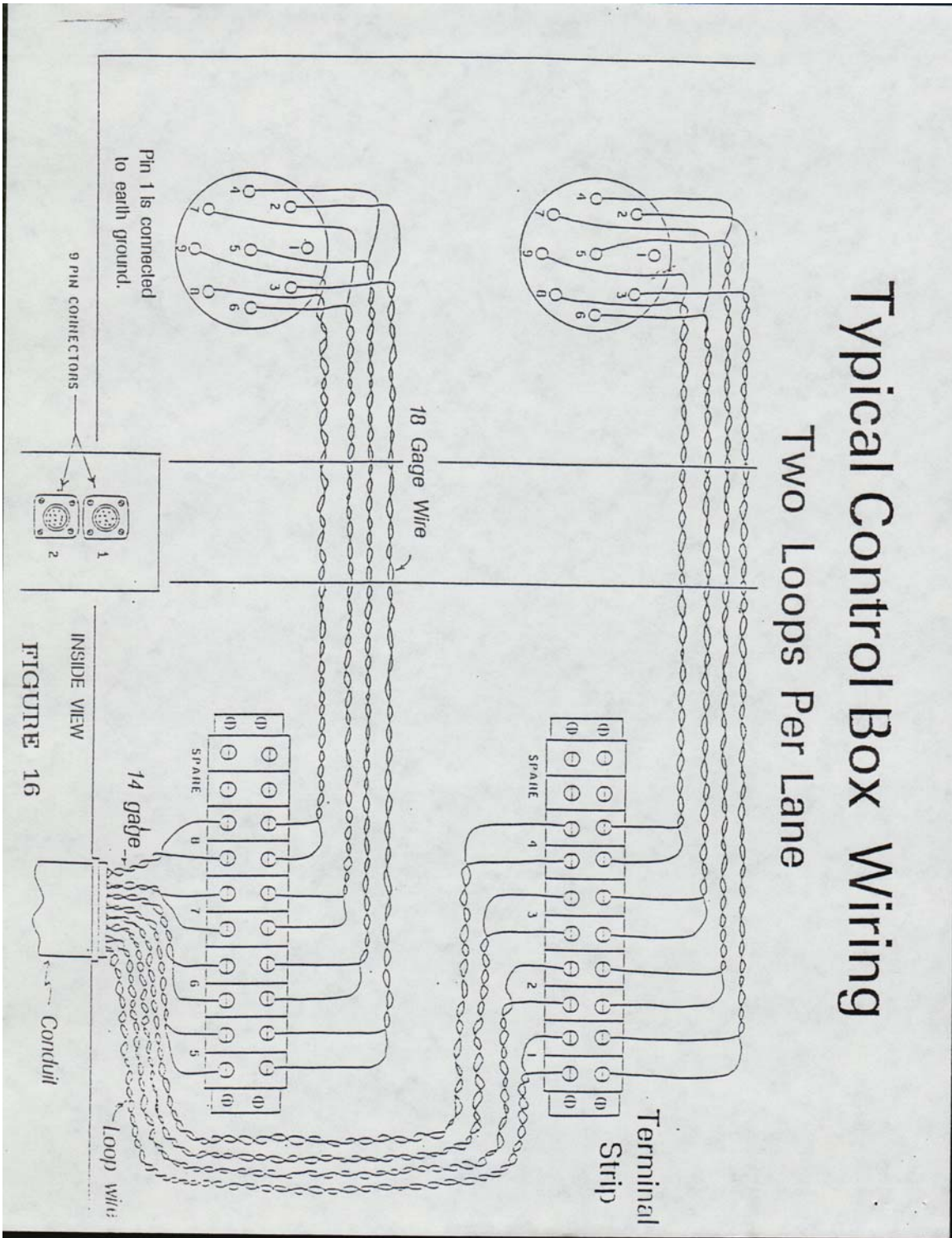

FIGURE 15

Typical Control Box Wiring

Two Loops Per Lane



Typical Control Box Wiring For Piezo Cables

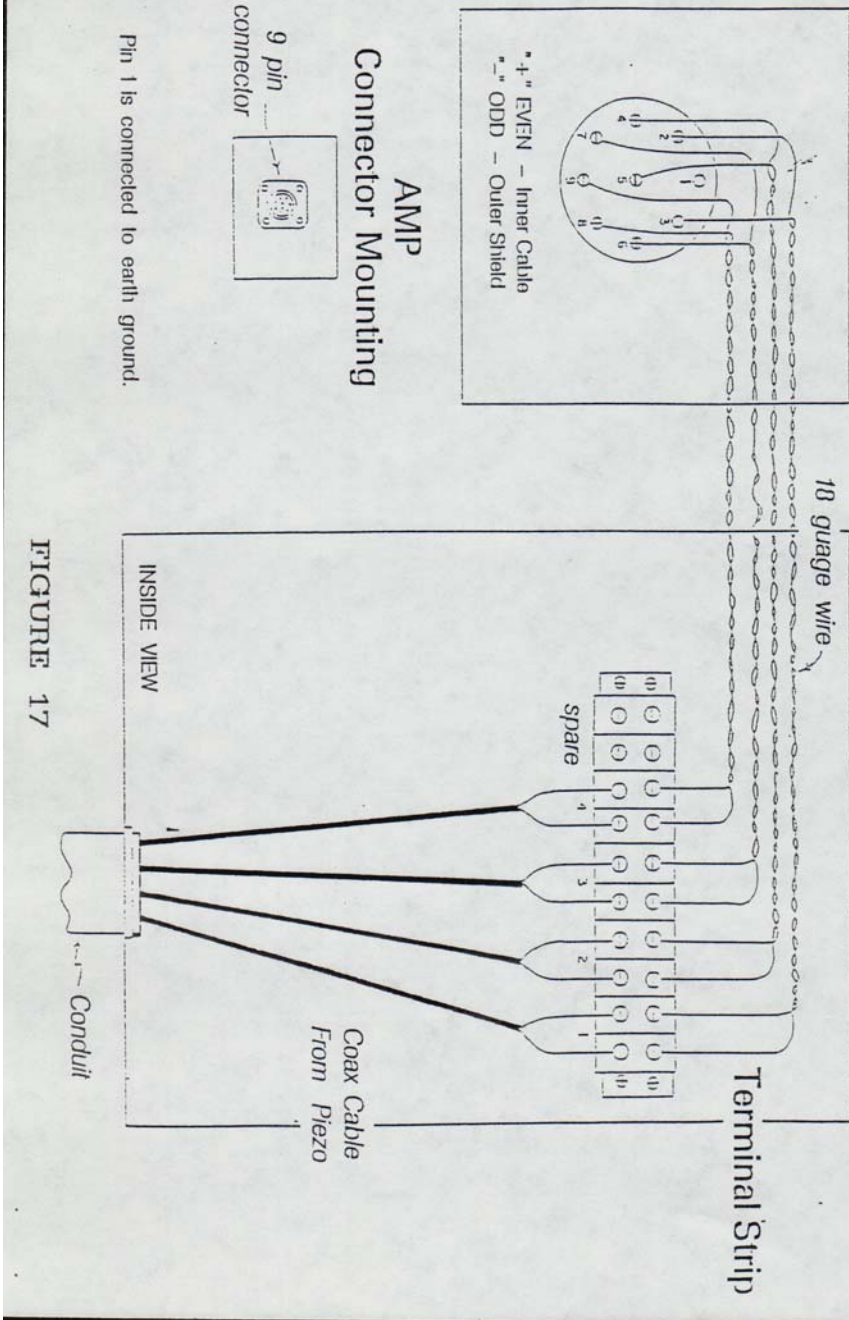

FIGURE 17