

**SCDOT**

**SEISMIC DESIGN SPECIFICATIONS**

**FOR**

**HIGHWAY BRIDGES**



**Version 2.0**  
**July 2008**



## FOREWORD

The South Carolina Department of Transportation (SCDOT or the Department) *Seismic Design Specifications for Highway Bridges* (Specifications) have been developed to provide the Department's bridge designers with a guide to design criteria, analysis methods and detailing procedures for the preparation of highway bridge plans. These Specifications supersede the seismic design requirements of the AASHTO LRFD Bridge Design Specifications for seismic design and analysis of South Carolina bridges.

The primary function of the Specifications is to provide minimum requirements for use by bridge designers to achieve public safety in an earthquake that is likely to occur in the State of South Carolina. The implementation of the Specifications is intended to safeguard against major failures and loss of life, to minimize damage, to maintain functions, and/or to provide for expedited repair.

Each bridge presents a unique set of design challenges. The designer must determine the appropriate methods and level of refinement necessary to design and analyze each bridge on a case-by-case basis. The designer must exercise sound engineering judgment in the application of these Specifications. Therefore, these Specifications are not intended to preclude the exercise of individual initiatives in reaction to site-specific conditions or application of current state of the art practices. It is important that any deviation from the Specifications be documented, along with rationale for the deviations. Any design exceptions to the Specifications shall be reviewed and approved by SCDOT in accordance with SCDOT standard procedures.

The Specifications were developed for SCDOT's use. SCDOT does not warrant the Specifications to be standards required by any other entity for purposes other than for SCDOT.

## ACKNOWLEDGEMENTS

Version 2.0 of the SCDOT *Seismic Design Specifications for Highway Bridges* was developed by the Department with assistance from STV/Ralph Whitehead Associates, Inc., Carolina Stalite Company, Fugro, and PBS&J, (San Diego office). A special thanks is given to CALTRANS Office of Earthquake Engineering and the Federal Highway Administration South Carolina Division Bridge Engineer for their assistance in developing these Specifications. These *Specifications* were based on the SCDOT Seismic Design Specifications, Version 1.0, 2001 as developed with the assistance of Dr. Roy Imbsen from Imbsen & Associates Inc (IAI).

## REVISION PROCESS

The *Specifications* are intended to provide current bridge seismic design policies and procedures for use in developing State highway projects. To ensure that the Specifications remain up-to-date and appropriately reflect changes in SCDOT's needs and requirements, its contents will be updated on an ongoing basis. It is the responsibility of the Specifications holder to keep the Specifications updated.

The SCDOT Seismic Design Support Section will monitor changes in bridge seismic design practices and will ensure that those changes are appropriately addressed through the issuance of revisions to the Specifications. It is important that users of the Specifications inform SCDOT of any inconsistencies, errors, need for clarification, or new ideas to support the goal of providing the best and most up-to-date practical information. Comments may be forwarded to the SCDOT Seismic Design Support Section.



**TABLE OF CONTENTS**

**SECTION 1 – INTRODUCTION.....1-1**

1.1 BACKGROUND ..... 1-1

1.2 PURPOSE AND PHILOSOPHY ..... 1-1

1.3 PERFORMANCE BASED DESIGN ..... 1-1

1.4 APPLICABILITY OF THE SPECIFICATIONS ..... 1-2

1.5 DEFINITION OF TYPICAL SCDOT BRIDGES ..... 1-2

1.6 REFERENCES ..... 1-3

**SECTION 2 – DEFINITIONS AND NOTATION.....2-1**

2.1 DEFINITIONS..... 2-1

2.2 NOTATION..... 2-2

**SECTION 3 – GENERAL REQUIREMENTS .....3-1**

3.1 SEISMIC DESIGN APPROACH ..... 3-1

3.2 OPERATIONAL CLASSIFICATION (OC) ..... 3-1

3.3 GROUND MOTIONS AND DESIGN EARTHQUAKES ..... 3-1

3.4 SEISMIC PERFORMANCE LEVELS AND PERFORMANCE OBJECTIVES ..... 3-3

    3.4.1 Seismic Performance Service Levels ..... 3-3

    3.4.2 Seismic Performance Damage Levels ..... 3-3

3.5 SEISMIC DESIGN CATEGORY (SDC) ..... 3-6

3.6 SEISMIC DEMAND ..... 3-6

3.7 SEISMIC CAPACITY OF STRUCTURAL COMPONENTS ..... 3-8

3.8 SEISMIC DEMAND VS. STRUCTURAL CAPACITY ..... 3-8

3.9 DESIGN REQUIREMENTS FOR SINGLE SPAN BRIDGES OR SDC A BRIDGES ..... 3-8

3.10 DESIGN REQUIREMENTS FOR SDC B, C and D BRIDGES ..... 3-8

3.11 DESIGN REQUIREMENTS FOR TEMPORARY BRIDGES AND STAGED CONSTRUCTION ..... 3-8

3.12 DESIGN REQUIREMENTS FOR PEDESTRIAN BRIDGES ..... 3-8

3.13 SEISMIC DESIGN FLOW CHARTS ..... 3-8

    3.13.1 Seismic Design Category A or Single Span Bridges ..... 3-8

    3.13.2 Seismic Design Category B ..... 3-9

    3.13.3 Seismic Design Category C ..... 3-9

    3.13.4 Seismic Design Category D ..... 3-9

**SECTION 4 – SEISMICITY, GEOTECHNICAL AND FOUNDATION DESIGN CONSIDERATIONS .....4-1**

4.1 INTRODUCTION ..... 4-1

    4.1.1 SOUTH CAROLINA GEOLOGY ..... 4-1

    4.1.2 SOUTH CAROLINA SEISMICITY ..... 4-1

4.2 SITE CLASSIFICATION ..... 4-3

4.3 DESIGN EARTHQUAKE GROUND MOTIONS ..... 4-3

4.4 DESIGN RESPONSE SPECTRUM BASED ON GENERAL PROCEDURE ..... 4-5

4.5 SITE-SPECIFIC RESPONSE SPECTRUM ..... 4-6

4.6 DESIGN EARTHQUAKE ACCELERATION TIME HISTORIES ..... 4-6

4.7 LIQUEFACTION ..... 4-7

4.8 VERTICAL SETTLEMENT ..... 4-7

4.9 EMBANKMENT SLOPE STABILITY ..... 4-7

4.10	SPECIAL PILE REQUIREMENTS .....	4-7
4.11	END BENTS.....	4-8
4.11.1	Free Standing End Bents and Retaining Walls.....	4-8
4.11.2	Integral/Semi-integral End Bents.....	4-8
4.11.3	Design Requirements for End Bents.....	4-8
4.12	SEISMIC HAZARD MITIGATION .....	4-9
<b>SECTION 5 - SEISMIC DISPLACEMENT DEMAND .....</b>		<b>5-1</b>
5.1	GENERAL REQUIREMENTS .....	5-1
5.1.1	Analysis Objectives .....	5-1
5.1.2	Exception for Single Span Bridges.....	5-1
5.1.3	Exception for SDC A Bridges.....	5-1
5.1.4	Balanced Stiffness.....	5-1
5.1.5	Balanced Unit Geometry.....	5-1
5.1.6	Adjusting Dynamic Characteristics .....	5-2
5.1.7	Vertical Ground Motion Considerations.....	5-2
5.1.8	Load Combinations.....	5-2
5.2	ANALYTICAL PROCEDURES AND APPLICATIONS.....	5-4
5.2.1	Special Requirements for Curved Bridges.....	5-4
5.2.2	Special Requirements for Geometrically Complex Bridges.....	5-4
5.2.3	Damping Considerations.....	5-6
5.2.4	Displacement Magnification for Short Period Structures .....	5-6
5.3	GLOBAL VS. LOCAL MODELS .....	5-6
5.4	COMBINATION OF ORTHOGONAL SEISMIC DISPLACEMENTS .....	5-7
5.5	MULTIMODE SPECTRUM ANALYSIS MODELING .....	5-7
5.5.1	Mode Shapes and Mass Participation .....	5-7
5.5.2	Superstructure Modeling.....	5-7
5.5.3	Interior Bent Modeling .....	5-7
5.5.4	Compression Model.....	5-7
5.5.5	Tension Model .....	5-7
5.5.6	Bearings .....	5-8
5.5.7	Effective Section Properties.....	5-10
5.6	END BENT SOIL STRUCTURE INTERACTION.....	5-11
5.6.1	End Bent Pile Stiffness .....	5-11
5.6.2	Backwall / Wingwall Modeling.....	5-12
5.7	SUBSTRUCTURE POINT OF FIXITY.....	5-13
5.8	INTERPRETATION / VERIFICATION OF MSA RESULTS.....	5-17
5.9	TIME HISTORY ANALYSIS.....	5-17
5.10	STAND-ALONE ANALYSIS.....	5-17
<b>SECTION 6 - SEISMIC DISPLACEMENT CAPACITY .....</b>		<b>6-1</b>
6.1	ANALYSIS OBJECTIVES .....	6-1
6.2	DEFINITION OF PLASTIC HINGES .....	6-1
6.3	LOCATIONS OF PLASTIC HINGES .....	6-1
6.4	PLASTIC HINGE ACCESSIBILITY .....	6-2
6.5	DISPLACEMENT CAPACITY OF DUCTILE CONCRETE MEMBERS .....	6-2
6.5.1	Ductile Member Definition.....	6-2
6.5.2	Member Displacement Capacity.....	6-5
6.5.3	Simplified Displacement Capacity for SDC B Bridges.....	6-10
6.5.4	Simplified Yield Displacement for SDC B Bridges .....	6-10



6.6	MATERIAL PROPERTIES FOR CONCRETE COMPONENTS.....	6-10
6.6.1	Expected Material Properties.....	6-10
6.6.2	Nonlinear Reinforcement Steel Model for Ductile Reinforced Concrete Members.....	6-10
6.6.3	Nonlinear Prestressing Strand Model.....	6-11
6.6.4	Unconfined Concrete Model.....	6-12
6.6.5	Confined Concrete Model.....	6-12
6.6.6	Structural Steel Material Properties.....	6-14
6.6.7	Normal Weight Portland Cement Concrete Properties.....	6-14
6.6.8	Sand-Lightweight Concrete Properties.....	6-14
6.6.9	Other Material Properties.....	6-14
6.7	PLASTIC MOMENT CAPACITY FOR DUCTILE CONCRETE MEMBERS.....	6-14
6.7.1	Analytical Modeling of Composite Section.....	6-14
6.7.2	Interpretation of Analysis Results.....	6-14
6.7.3	Reinforced Concrete Moment Curvature ( $M-\phi$ ) Analysis.....	6-15
6.7.4	Prestressed Concrete Moment Curvature ( $M-\phi$ ) Analysis.....	6-15
6.7.5	Shear and Moment Capacity.....	6-15
6.8	PUSH-OVER ANALYSIS.....	6-17
6.8.1	Load-Displacement (P-Y) Curves.....	6-17
6.8.2	Moment Rotation Hinges.....	6-17
6.9	REQUIREMENTS FOR CAPACITY-PROTECTED COMPONENTS.....	6-18
<b>SECTION 7 - DEMAND VERSUS CAPACITY.....</b>		<b>7-1</b>
7.1	PERFORMANCE CRITERIA.....	7-1
7.1.1	Global Displacement Criteria.....	7-1
7.1.2	Substructure Unit Ductility Demand.....	7-1
7.1.3	Ductility Capacity.....	7-1
7.2	P- $\Delta$ EFFECTS.....	7-1
<b>SECTION 8 – CAST-IN-PLACE CONCRETE DESIGN AND DETAILING.....</b>		<b>8-1</b>
8.1	SDC A AND SINGLE SPAN BRIDGES MINIMUM REQUIREMENTS.....	8-1
8.2	SDC B, C AND D BRIDGES MINIMUM REQUIREMENTS.....	8-1
8.2.1	Force Demands for Substructure Units Behaving Elastically.....	8-1
8.2.2	Force Demands For Capacity Protected Elements.....	8-1
8.2.3	Column Flexural Demands.....	8-1
8.2.4	Column Shear Demand.....	8-1
8.2.5	Pier Wall Shear Demand.....	8-1
8.3	VERTICAL GROUND MOTION DETAILING.....	8-1
8.4	DUCTILE MEMBER DESIGN REQUIREMENTS FOR SDC B, C AND D.....	8-2
8.4.1	Minimum Lateral Strength.....	8-2
8.4.2	Maximum Axial Load in a Ductile Member.....	8-2
8.4.3	Maximum Longitudinal Reinforcement.....	8-2
8.4.4	Minimum Longitudinal Reinforcement.....	8-2
8.4.5	Splicing of Longitudinal Reinforcement in Columns.....	8-2
8.4.6	Minimum Development Length of Longitudinal Column Reinforcement.....	8-3
8.4.7	Anchorage of Bundled Bars in Ductile Components.....	8-3
8.4.8	Maximum Bar Diameter.....	8-3
8.4.9	Minimum Development Length of Longitudinal Column Reinforcement Extended into Oversized Shafts.....	8-3
8.4.10	Transverse Reinforcement Inside the Plastic Hinge Region.....	8-3
8.4.11	Transverse Reinforcement Outside the Plastic Hinge Region.....	8-3

8.4.12	Maximum Spacing for Transverse Reinforcement .....	8-3
8.4.13	Transverse Reinforcement Requirements for Columns on Oversized Drilled Shafts.....	8-4
8.4.14	Transverse Confinement for Oversized Drilled Shafts .....	8-4
8.4.15	Lateral Confinement for Non-Oversized Strengthened Drilled Shafts .....	8-4
8.5	CAPACITY PROTECTED ELEMENT DESIGN REQUIREMENTS .....	8-4
8.6	SHEAR DESIGN.....	8-8
8.6.1	Concrete Subject to Flexure and Compression.....	8-8
8.6.2	Strength of Transverse Reinforcement .....	8-8
8.7	BENT CAP JOINT SHEAR DESIGN.....	8-9
8.7.1	Principal Stresses in Connections .....	8-9
8.7.2	Maximum Allowable Principal Stress .....	8-10
8.7.3	Minimum Required Horizontal Reinforcement .....	8-12
8.7.4	Conventional Bent Cap-Column Joints .....	8-12
8.7.5	Vertical Reinforcement.....	8-12
8.7.6	Additional Cap Longitudinal Reinforcement.....	8-12
8.7.7	Hoop Transverse Confinement Reinforcement.....	8-13
8.7.8	Knee Joints.....	8-13
8.8	FOOTING JOINT SHEAR DESIGN .....	8-16
8.8.1	Footing-Column Joints .....	8-16
8.8.2	Vertical Reinforcement.....	8-16
8.8.3	Horizontal Reinforcement.....	8-16
8.8.4	Hoop Transverse Confinement Reinforcement.....	8-16
8.9	INTEGRAL BENT CAP JOINT SHEAR .....	8-18
8.9.1	Integral Superstructure-Column Joints .....	8-18
8.9.2	Integral Superstructure Joint Proportioning.....	8-18
8.9.3	Vertical Reinforcement.....	8-18
8.9.4	Additional Flexural Reinforcement .....	8-18
8.9.5	Horizontal Reinforcement.....	8-18
8.9.6	Hoop Transverse Confinement Reinforcement.....	8-18
<b>SECTION 9 – MISCELLANEOUS DETAILING.....</b>		<b>9-1</b>
9.1	MINIMUM SUPPORT LENGTH.....	9-1
9.1.1	SDC A and Single Span Bridges .....	9-1
9.1.2	SDC B and C Bridges .....	9-1
9.1.3	SDC D Bridges .....	9-1
9.2	LONGITUDINAL AND TRANSVERSE CONNECTIONS.....	9-1
9.2.1	Anchor Bolt Design .....	9-2
9.2.2	Concrete Superstructure Shear Key Design.....	9-2
9.2.3	Steel Superstructure Shear Key Design .....	9-2
9.2.4	Integral Backwall Design.....	9-2
9.3	END BENT FUSE DETAILING.....	9-3
9.3.1	Transverse Direction (in the direction of centerline of end bent cap).....	9-4
9.3.2	Longitudinal Direction (in the direction of centerline of the bridge).....	9-4
9.4	OTHER DETAILS AND REQUIREMENTS .....	9-4
9.4.1	Prestressed Concrete Beam End Diaphragms at Expansion Joints.....	9-4
9.4.2	Prestressed Concrete Beam Closure Diaphragms .....	9-4
9.4.3	Retainer Blocks.....	9-5
9.4.4	HP Pile Details.....	9-5
9.4.5	Column Flares.....	9-5

**LIST OF FIGURES**

Figure 1.1 Displacement vs. Lateral Force ..... 1-2

Figure 3.1 Flow Chart to Determine SDC ..... 3-6

Figure 3.2 Flow Chart for SDC A and Single Span Bridges ..... 3-9

Figure 3.3 Flow Chart for SDC B ..... 3-10

Figure 3.4 Flow Chart for SDC C ..... 3-11

Figure 3.5 Flow Chart for SDC D ..... 3-12

Figure 4.1 SC Geographic Regions ..... 4-1

Figure 4.2 Coastal Plain Sediment Thickness ..... 4-2

Figure 4.3 Design Response Spectrum ..... 4-6

Figure 5.1 Balanced Stiffness ..... 5-3

Figure 5.2 Subtended Angle Definition ..... 5-4

Figure 5.3 MSA Modeling Procedure ..... 5-5

Figure 5.4 Bearing Modeling Procedure (Longitudinal Direction) ..... 5-9

Figure 5.5 End Bent Pile Force v/s Displacement ..... 5-11

Figure 5.6 Backwall Stiffness Model ..... 5-12

Figure 5.7 End Bent MSA Modeling Flowchart ..... 5-14

Figure 5.8 Possible Point of Fixity Locations ..... 5-15

Figure 5.9 Iterative Calibration of SSI and MSA Models for Foundation Point of Fixity ..... 5-16

Figure 6.1 Potential Plastic Hinge Locations ..... 6-3

Figure 6.2 Typical and Oversized Drilled Shafts ..... 6-4

Figure 6.3 Displacement Capacity for One Cantilever Segment (Longitudinal or Free Head) ..... 6-6

Figure 6.4 Displacement Capacity for Two Cantilever Segments (Transverse or Fixed Head) ..... 6-7

Figure 6.5 Displacement Capacity for Column/Drilled Shaft (Longitudinal) ..... 6-8

Figure 6.6 Displacement Capacity for Column/Drilled Shaft (Transverse) ..... 6-9

Figure 6.7 Reinforcement Steel Stress-Strain Model ..... 6-11

Figure 6.8 Grade 270 Low Relaxation Prestressing Strand Stress-Strain Model ..... 6-11

Figure 6.9 Unconfined Concrete Stress-Strain Model ..... 6-12

Figure 6.10 Confined Concrete Stress-Strain Model ..... 6-14

Figure 6.11 Bi-Linear Moment Curvature Curve for Reinforced Concrete Sections ..... 6-15

Figure 6.12 Tri-Linear Moment Curvature Curve for Prestressed Concrete Pile Sections ..... 6-15

Figure 6.13 Moment Diagram for SCDOT Typical Multi-Column Bent ..... 6-16

Figure 6.14 Example P-Y Curve ..... 6-17

Figure 6.15 Bi-Linear P-Y Curve Approximation ..... 6-17

Figure 6.16 Bi-Linear Moment Rotation Curve (Fixed Hinge) ..... 6-18

Figure 6.17 Tri-Linear Moment Rotation Curve (Fixed Hinge) ..... 6-18

Figure 6.18 Bi-Linear Moment Rotation Curve (Free Hinge) ..... 6-18

Figure 6.19 Tri-Linear Moment Rotation Curve (Free Hinge) ..... 6-18

Figure 8.1 Equivalent Static Vertical Loads and Moments ..... 8-2

Figure 8.2 Transverse Reinforcement for Column on a Non-oversized Drilled Shaft ..... 8-5

Figure 8.3 Transverse Reinforcement for a Column on a Pile Footing ..... 8-6

Figure 8.4 Reinforcement for Column on Oversized Drilled Shaft ..... 8-7

Figure 8.5 Joint Shear Principal Stress Diagrams ..... 8-11

Figure 8.6 Conventional Bent Cap to Column Joint Shear Reinforcement ( $L_c > 0.5D_c$ ) ..... 8-14

Figure 8.7 Conventional Bent Cap to Column Joint Shear Reinforcement ( $L_c < 0.5D_c$ ) ..... 8-15

Figure 8.8 Vertical Joint Shear Reinforcement Location ..... 8-17

Figure 8.9 Footing Joint Shear Reinforcement ..... 8-17

Figure 8.10 Integral Column to Superstructure Joint Shear Reinforcement - Plan ..... 8-19

Figure 8.11 Integral Column to Superstructure Joint Shear Reinforcement – Section A-A ..... 8-20

Figure 9.1 Dimensions for Support Length Requirement ..... 9-1

Figure 9.2 Concrete Superstructure Shear Key ..... 9-3

Figure 9.3 Steel Superstructure Shear Key ..... 9-3

Figure 9.4 Example End Diaphragm ..... 9-6

Figure 9.5 Example Closure Diaphragm ..... 9-7

Figure 9.6 Retainer Block Details ..... 9-8

Figure 9.7 Pile Anchorage Detail ..... 9-9

## LIST OF TABLES

Table 3.1 Bridge Operational Classification (OC).....	3-2
Table 3.2 Bridge Seismic Analysis Requirements.....	3-2
Table 3.3 Bridge System (Global) Seismic Performance Objectives .....	3-4
Table 3.4 Bridge Components (Local) Damage Level Objectives .....	3-5
Table 3.5 Seismic Design Category (SDC) .....	3-6
Table 3.6 Bridge System Seismic Displacement Performance Limits.....	3-7
Table 4.1 Site Classes .....	4-3
Table 4.2 Site Class Category.....	4-4
Table 4.3 Values of $F_{PGA}$ and $F_a$ as a Function of Site Class and Mapped Short-Period Spectral Response Acceleration $S_s$ .....	4-5
Table 4.4 Values of $F_v$ as a Function of Site Class and Mapped Spectral Response Acceleration at 1.0 Second Period $S_1$ .....	4-5
Table 5.1 Regular Bridge Requirements.....	5-4
Table 6.1 Plastic Hinge Locations .....	6-2
Table 7.1 Substructure Unit Quantitative Damage Criteria (Maximum Ductility Demand $\mu_d$ ).....	7-2



## **Section 1**

# **INTRODUCTION**

## **SCDOT Seismic Design Specifications for Highway Bridges**





## TABLE OF CONTENTS

<b>SECTION 1 – INTRODUCTION.....</b>	<b>1-1</b>
1.1 BACKGROUND .....	1-1
1.2 PURPOSE AND PHILOSOPHY .....	1-1
1.3 PERFORMANCE BASED DESIGN .....	1-1
1.4 APPLICABILITY OF THE SPECIFICATIONS .....	1-2
1.5 DEFINITION OF TYPICAL SCDOT BRIDGES.....	1-2
1.6 REFERENCES .....	1-3



## SECTION 1 – INTRODUCTION

### 1.1 BACKGROUND

The South Carolina Department of Transportation (SCDOT or Department) developed the "SCDOT Seismic Design Specifications for Highway Bridges" in October 2001, which incorporated "Recommended LRFD Guidelines for Seismic Design of Highway Bridges" (NCHRP Project 12-49) and Caltrans "Seismic Design Criteria, July 1999". Probabilistic ground motion hazard maps produced in 1996 by the U.S. Geological Survey (USGS) were incorporated into the Specifications.

Interim revisions were issued in 2002 after initial release of the Specifications. After the release of the Specifications, SCDOT performed studies of probabilistic seismic hazard mapping for South Carolina. Significant differences were found between the USGS maps and South Carolina seismic hazard maps, which reflect actual geological conditions in South Carolina.

Based on current research and lessons learned, SCDOT decided to update the Seismic Design Specifications for Highway Bridges (Specifications) in 2005. The updated seismic Specifications incorporate information from the recent study of South Carolina Seismic Hazard Maps for Bridges and Highways, "Recommended LRFD Guidelines for the Seismic Design of Highway Bridges" (May 2006) "Recommended LRFD Guidelines for the Seismic Design of Highway Bridges" (MCEER/ATC-49, 2003), Caltrans Seismic Design Criteria, June 2006, Version 1.4, recent research and SCDOT bridge design standard practice.

### 1.2 PURPOSE AND PHILOSOPHY

The SCDOT Seismic Design Specifications for Highway Bridges establish design provisions for bridges in South Carolina to minimize their susceptibility to collapse from large earthquakes. The recommended seismic design procedures were developed to meet current bridge code objectives, including both serviceability and life safety in the event of a large earthquake.

The primary function of these provisions is to provide minimum standards for use in bridge design, and to maintain public safety in the event of a large and rare earthquake within the state of South Carolina. They are intended to safeguard against

major failures, loss of life, and provide for easy repair.

The principles used for the development of the Specifications are:

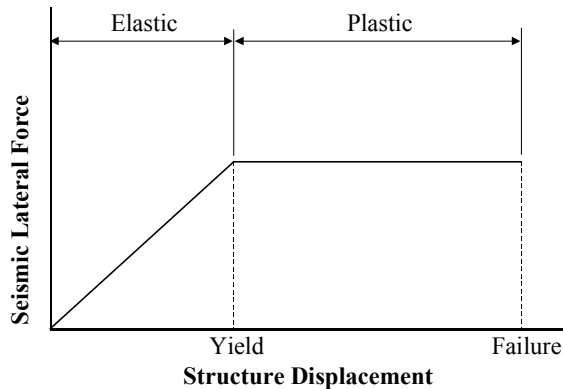
- Loss of life and serious injuries due to unacceptable bridge performance should be minimized.
- Bridges may suffer severe damage and may need to be replaced, but they should have a low probability of collapse due to earthquake motions.
- The functionality of certain bridges shall be maintained even after a major earthquake.

### 1.3 PERFORMANCE BASED DESIGN

These Specifications follow the performance based design methodology. The bridge structures shall be designed to satisfy certain performance levels and performance objectives as described in Section 3.4. With this concept, the substructure elements are designed to allow plastic hinging and plastic deformation while keeping the superstructure deformations in the elastic range. Under the design earthquake, ductile substructure components are expected to experience plastic deformation in addition to the elastic displacement (see Figure 1.1). This design approach requires the structure system and its individual components be designed to have enough capacity to withstand the deformations imposed by the design earthquake.

This design approach is used instead of the traditional force based design approach to overcome the drawbacks of the latter design approach which:

- Does not directly address the inelastic nature of a structural system.
- Requires the use of somewhat an arbitrary force-reduction factor.
- Provides little insight into actual structural behavior.
- Does not provide a consistent level of protection against reaching a specified limit state.



**Figure 1.1 Displacement vs. Lateral Force**

#### 1.4 APPLICABILITY OF THE SPECIFICATIONS

These Specifications were developed for the design and construction of new bridges to resist the effects of earthquake motions. The provisions apply to bridges of conventional slab, beam, girder and box girder superstructure construction with spans not exceeding 300 ft. For other types of construction (suspension bridges, cable-stayed bridges, arch type and movable bridges) and spans exceeding 300 ft, the SCDOT shall specify and/or approve appropriate provisions.

These Specifications shall apply not only to standard SCDOT seismic bridge design, but also to Value Engineering (VE) as well as Design Build (DB) projects.

Seismic effects for box culverts and buried structures need not be considered, except when they are subject to unstable ground conditions (e.g., liquefaction, landslides, and fault displacements) or large ground deformations (e.g., in very soft ground).

The provisions in the Specifications are minimum performance requirements. Additional provisions may be needed to achieve higher performance criteria. Those provisions shall be site and project specific.

#### 1.5 DEFINITION OF TYPICAL SCDOT BRIDGES

Additional design considerations and detailing, which are not included in these Specifications, may be required for some SCDOT structures. The following types of bridge elements are considered typical for SCDOT bridges:

##### Typical Superstructure Types

- Prestressed concrete cored slabs
- Cast-in-Place flat slabs
- Deck slab supported on prestressed concrete beams
- Deck slab supported on steel plate girders or rolled beams

Although concrete box girder superstructures are not commonly used in the State of South Carolina, seismic design and detailing for this type of bridge shall be performed in accordance with these Specifications.

##### Typical Substructure Types

- Prestressed concrete pile bents (with cast-in-place bent cap)
- Pier walls
- Hammerhead bents
- Cast-in-place post and beam concrete bents
- Free standing end bents
- Integral/semi-integral end bents

##### Typical Foundation Types

- Drilled shafts (including oversized drilled shafts)
- Prestressed concrete piles
- Steel HP piles
- Spread footings

## 1.6 REFERENCES

- AASHTO (2007) *Guide Specifications for LRFD Seismic Bridge Design*, American Association of State Highway and Transportation Officials, Washington, DC.
- AASHTO (2004) *LRFD Bridge Design Specifications, 3<sup>rd</sup> Ed.* American Association of State Highway and Transportation Officials, Washington, DC.
- ACI (1995) *Building Requirements for Structural Concrete (ACI 318-95) and Commentary (ACI 318R-95)*, American Concrete Institute, Farmington Hills, MI.
- AISC (1994) *Load Factor Design Manual of Steel Construction, 2<sup>nd</sup> Ed.* American Institute of Steel Construction, Chicago, IL.
- ATC-32 (1996), *Improved Seismic Design Criteria for California Bridges: Provisional Recommendations*. Applied Technology Council, Redwood City, CA.
- Bakeer, R.M., and Mattei, N.J. (2005) *Evaluation of DOTD Semi-integral Bridge and Abutment System*. Louisiana Transportation Research Center, Proj. No. 01-3ST. University of New Orleans, New Orleans, LA.
- Budek, A. et al. (1997) *Experimental Investigation of Ductility of In-ground Hinges in Solid and Hollow Prestressed Piles*. Structural Systems Research Project, Rep. No. SSRP-97/17. University of California at San Diego, La Jolla, CA.
- Building Seismic Safety Council (1997) *NEHRP Recommended Provisions for Seismic Regulations for New Buildings and Other Structures*, Report FEMA 302, Washington, DC.
- Caltrans (2004) *Seismic Design Criteria, Version 1.3*, California Department of Transportation, Sacramento, CA.
- FHWA (2006) *Seismic Retrofitting Manual for Highway Structure: Part I – Bridges*, FHWA-HRT-06-032.
- Frankel, A. et al. (1996) *Interim National Seismic Hazard Maps: Documentation*, U.S. Geological Survey, Denver, CO.
- Harris, K. and Petrou, M. (2001) *Behavior of Precast, Prestressed Concrete Pile to Cast-in-Place Pile Cap Connections*. PCI Journal, 46(4), pp 82-92, Chicago, IL.
- Hawkins, N. M. et al. (2005) *Simplified Shear Design of Structural Concrete Members*. National Cooperative Highway Research Program, Rep. No. 549. Transportation Research Board, Washington, DC.
- Imbsen, R. (2006) *Recommended LRFD Guidelines for the Seismic Design of Highway Bridges*. AASHTO Highway Subcommittee on Bridge and Structures.
- Inouye, B. et al. (2005) *Seismic Analysis and Retrofit Study of the SR 99 – Spokane Street Overcrossing*. Washington State Transportation Center, Rep. No. WA-RD 596.1, University of Washington, Seattle, WA.
- Joel, P. et al. (1988) *Seismic Performance of Prestressed Concrete Piles and Pile – Pile Cap Connections*, Report No. 88-3, Department of Civil Engineering, University of Canterbury, Christchurch, New Zealand.
- Kowalsky, Mervyn J. (2000) *Deformation Limit States for Circular Reinforced Concrete Bridge Columns*. ASCE Journal of Structural Engineering, 126(8), pp 869-878, Reston, VA.
- Mander, J.B. et al. (1988) *Theoretical Stress-Strain Model for Confined Concrete*. ASCE Journal of Structural Engineering, 114(8), pp 1804-1826, Reston, VA.
- MCEER/ATC 49 (2003) *Recommended LRFD Guidelines for the Seismic Design of Highway Bridges, Part I: Specifications*, Redwood City, CA.
- MCEER/ATC 49 (2003) *Recommended LRFD Guidelines for the Seismic Design of Highway Bridges, Part II: Commentary and Appendices*, Redwood City, CA.
- PCI (2004) *Precast Prestressed Concrete Piles, 1<sup>st</sup> Ed.* Precast/Prestressed Concrete Institute, Chicago, IL.
- Priestly, M.J.N. et al. (1996) *Seismic Design and Retrofit of Bridges*, John Wiley and Sons, New York, NY.
- Rojahn, C. et al. (1997) *Seismic Design Criteria for Bridges and Other Highway Structures*. National Center for Earthquake Engineering Research,

Rep. No. NCEER 97-0002. State University of New York at Buffalo, Buffalo, NY.

Silva, P. et al. (1997) *Response of Standard Caltrans Pile-to-Pile Cap Connections under Simulated Seismic Loads*. Structural Systems Research Project, Rep. No. SSRP-97/09. University of California at San Diego, La Jolla, CA.

Silva, P. et al. (1997) *Response of the Coronado Bay Bridge Pile-to-Pile Cap Connections under Simulated Seismic Loads*. Structural Systems Research Project, Rep. No. SSRP-97/11. University of California at San Diego, La Jolla, CA.

Silva, P. et al. (2001) *Influence of Strand Development Length in Formation of Plastic Hinges in Prestressed Piles*. PCI Journal, 46(3), pp 76-89, Chicago, IL.

SCDOT (2001) *SCDOT Seismic Design Specifications for Highway Bridges*, and Interims through 2002, South Carolina Department of Transportation, Columbia, SC.

Xiao, Y. (2003) *Experimental Studies on Precast Prestressed Concrete Pile to Pile-Cap Connections*. PCI Journal, 48(6), 82-91, Chicago, IL.

Xiao, Y. et al. (2006) *Experimental Studies on Seismic Behavior of Steel Pile-to-Pile-Cap Connections*. ASCE Journal of Bridge Engineering, 11(2), 151-159, Reston, VA.

## **Section 2**

# **DEFINITIONS AND NOTATION**

**SCDOT Seismic Design Specifications for Highway Bridges**





**TABLE OF CONTENTS**

**SECTION 2 – DEFINITIONS AND NOTATION.....2-1**  
2.1 DEFINITIONS.....2-1  
2.2 NOTATION.....2-2



## SECTION 2 – DEFINITIONS AND NOTATION

### 2.1 DEFINITIONS

**Abutment** – An end support of a bridge superstructure. It transmits the reaction of superstructure to the foundations and retains the earth filling behind the abutment back wall. Abutment is interchangeable with End Bent but most of time, the term Abutment is used when the concrete cap height exceeds 6'.

**Capacity Design** - A method of component design that allows the designer to prevent damage in certain components by making them stiff enough to resist loads that are generated when adjacent components reach their overstrength capacity.

**Capacity Protected Element** - Part of the structure that is either connected to a critical element or within its load path and that is prevented from yielding by virtue of having the critical member limit the maximum force that can be transmitted to the capacity protected element.

**Collapse** - The inability of a bridge or bridge span to support its self-weight.

**Complete Quadratic Combination (CQC)** - A statistical rule for combining modal responses from an earthquake load applied in a single direction to obtain the maximum response due to this earthquake load.

**Damage Level** - A measure of seismic performance based on the amount of damage expected after one of the design earthquakes.

**Design Earthquake** - The earthquake (SEE or FEE) used to determine anticipated structural displacement demand.

**Ductile Member** - Any member that is intentionally designed to deform inelastically for several cycles without significant degradation of strength or stiffness under the demands generated by the design earthquake.

**Embankment Global Stability** - The stability of a cut or fill slope where either a circular arc or a sliding block stability method can model the failure surface.

**Earthquake Resisting Element (ERE)** - The individual components, such as columns, connections, bearings, joints, foundation and abutments, that together constitute the Earthquake Resisting System (ERS).

**Earthquake Resisting System (ERS)** - A system that provides a reliable and uninterrupted load path for transmitting seismically induced forces into the ground and sufficient means of energy dissipation and/or restraint to reliably control seismically induced displacements.

**End Bent** – An end support of a bridge superstructure. It transmits the reaction of superstructure to the foundations and retains the earth filling behind the abutment back wall. The LRFD Specifications uses the term “abutment” to designate bridge end supports; SCDOT’s use of the term “end bent” is synonymous with the LRFD term “abutment.”

**Essentially Elastic** – The condition of an element under seismic loading, where concrete does not exceed the crushing stress and the steel stress does not exceed the elastic limit of material.

**Fixed Hinge** - Moment rotation hinge that models the rigid connection of a pile or column in a manner such that relative rotation between pile head and bent cap does not occur until the pile or column reaches the effective yield moment.

**Free Hinge** - Moment rotation hinge that models the pile or column in regions not in a rigid connection, where rotation occurs before the section reaches effective yield.

**Functional Evaluation Earthquake (FEE)** - The design seismic event with a 15% probability of exceedance in 75 years.

**Fundamental (Natural) Period** - The longest period in a certain direction for which a structure shows a maximum response. Defined as the reciprocal of the natural frequency.

**Operational Classification (OC)** - Structure classification from I to III that determines the design earthquakes and Seismic Design Category.

**Liquefaction** - The tendency to develop excess pore water pressure during the design seismic event, resulting in the sudden loss of strength and stiffness of the granular soils followed by densification of loose granular materials.

**Liquefaction Induced Lateral Flow** - Lateral displacement of relatively flat slopes that occurs from the combination of gravity loads and excessive pore water pressure (without inertial loading from earthquake). Lateral flow often occurs after cessation of earthquake loading.

**Liquefaction Induced Lateral Spreading** - Lateral displacement of a slope that occurs from the combined effects of pore water pressure buildup, inertial loads from the earthquake, and gravity loads.

**Minimum Support Length** - The minimum required width of a bearing seat that must be provided in a new bridge designed according to these Specifications.

**Multi-Modal Spectral Analysis (MSA)** – A dynamic analysis method which is used to model the bridge system as a three-dimensional space frame with joints and nodes to determine model coupling effects and multi-model contributions to the bridge seismic response.

**Oversized Drilled Shaft** – When a drilled shaft is at least one foot larger in diameter than the supported column and it has different longitudinal reinforcement cage than the supported column, the drilled shaft is called an Oversized Drilled Shaft.

**Overstrength Capacity** - The maximum expected force or moment that can be developed in a yielding structural element assuming expected material properties and large strains and associated stresses.

**Plastic Hinge** - The region of a structural component, usually a column or a pier, that undergoes flexural yielding and plastic rotation while still retaining sufficient flexural strength.

**Plastic Hinge Zone** - Regions of structural components that are subject to potential plastification and thus must be detailed accordingly.

**Pushover Analysis** - A non-linear analysis procedure that determines the structure displacement capacity.

**Safety Evaluation Earthquake (SEE)** - The design earthquake with a 3% probability of exceedance in 75 years.

**Seismic Design Category (SDC)** - Designation of a structure from A to D that determines the level of analysis and detailing required. Designation determined by the bridge operational classification and the design spectral response acceleration for the safety evaluation event at the one-second period.

**Short Period Structure** - Structure with a Fundamental (Natural) Period less than the characteristic ground motion period corresponding to the peak energy input spectrum.

**Site Class** - One of six classifications used to characterize the effect of the soil conditions on ground motion.

**Soil Structure Interaction (SSI)** – Analysis procedure which is used to develop the P-Y curves for the substructure elements.

**Square Root of the Sum of the Squares (SRSS) Combination** - In these Specifications, this classical statistical combination rule is used in two ways. The first is for combining forces resulting from two or three orthogonal ground motion components. The second use is for establishing orthogonal moments for biaxial design.

**Tributary Weight** - The portion of the weight of the superstructure that would act on a bent participating in the **FEE** or **SEE** events if the superstructure between participating bents consisted of simply supported spans. A portion of the weight of a substructure unit may also be included in the tributary weight when analyzing seismic demand on the substructure unit.

## 2.2 NOTATION

The following symbols, and definitions apply to these Specifications:

$A_b$	Cross-sectional area of anchor bolt
$A_{brg}$	Plan area of elastomeric bearing
$A_c$	Area of column core measured to outside of transverse confining reinforcement
$A_{cv}$	Area of concrete in the shear plane
$A_e$	Effective shear area
$A_g$	Gross area of column, pile or pier wall

$A_s^{anchor}$	Area of concrete in the shear plane (in <sup>2</sup> )	$E_{ce}$	Elastic modulus of concrete using expected material properties
$A_s^{bot}$	Area of flexural reinforcement in the bottom layer of the bent cap	$E_{ps}$	Modulus of elasticity of prestressing steel
$A_s^{bw}$	Area of steel in the backwall crossing the shear plane	$EQ$	Seismic loading
$A_s^{jf}$	Additional longitudinal reinforcement	$E_s$	Steel elastic modulus
$A_s^{ji}$	Vertical beam stirrup reinforcement	$E_{sec}$	Secant modulus of concrete at peak stress
$A_s^{jh}$	Area of horizontal stirrups	$F_a$	Site coefficient defined in Table 4.3 based on the site class and the values of the mapped response acceleration parameter $S_s$
$A_s^{jv}$	Area of vertical joint shear reinforcement	$F_{max}$	Maximum backwall or wingwall force from passive pressure resistance
$A_s^{sf}$	Area of longitudinal side face reinforcement in the bent cap	$F_{PGA}$	Site coefficient for peak ground acceleration
$A_s^{sk}$	Area of reinforcement crossing the shear plane	$F_{pile}$	Top of pile force on the bi-linear model corresponding to the estimated displacement
$A_s^{top}$	Area of flexural reinforcement in the top layer of the bent cap	$F_{ub}$	Specified minimum tensile strength of the anchor bolt
$A_{st}$	Total area of longitudinal reinforcement in the column / shaft	$F_v$	Site coefficient defined in Table 4.4 based on the site class and the values of the mapped response acceleration parameter $S_I$
$A_v$	Area of transverse reinforcement bars	$F_y$	Specified structural steel yield stress
$D$	Column diameter or pile width in the direction of bending	$F_y^{pile}$	Estimated yield force of bi-linear model at yield point
$D'$	Confined core diameter of a column or effective depth of a rectangular member	$G$	Shear modulus of the elastomer
$D^*$	Diameter or cross section dimension in direction of bending	$H$	Height of the substructure measured from top of cap to top of footing, or point of fixity of drilled shaft/driven pile
$D_c$	Diameter or maximum cross sectional dimension of column	$H'$	Length of pile/column from point of maximum moment below ground to point of contraflexure above ground
$D_{c,max}$	Largest cross-sectional dimension of the column	$H_{bw}$	Height of backwall and cap or wingwall exposed to passive earth pressure
$DL$	Dead load of structure and all attachments	$H_s$	The largest column height in the most flexible frame adjacent to the expansion joint under consideration. The average height from the top of column to top of pile footing, or to the point of fixity of drilled shaft or driven pile foundations. For single spans seated on
$E$	Modulus of elasticity of column, pile or drilled shaft using expected material properties		
$E_c$	Elastic modulus of concrete		

	abutments, the term is taken as the abutment height	$M_{po}$	Overstrength plastic hinge moment
$I$	Moment of inertia of column for pile footing or oversized shaft foundations, or drilled shaft for drilled shaft foundations	$M_{sh}$	Moment at the idealized onset of strain hardening
$I_{eff}$	Effective flexural moment of inertia	$M_u$	Ultimate moment (point where section reaches failure)
$I_g$	Gross section moment of inertia	$M_y$	Moment of the section at first yield of the reinforcement steel
$J_{eff}$	Effective torsional moment of inertia	$M_{yeff}$	Effective plastic hinge moment of pile
$J_g$	Gross torsional moment of inertia	$N$	Minimum support length
$L$	Total expansion length at the joint or distance from the point of maximum moment to the point of contraflexure	$N_{ab}$	Number of anchor bolts
$LL$	Live load without impact	$N_d$	Differential seismic movement between superstructure and substructure
$L'$	Length of column from point of contraflexure to cap, footing or oversized shaft	$P_b$	Axial force in the cap including prestress
$L_l$	Length of column from top of column to point of contraflexure	$P_{col}$	Axial load including overturning effects
$L_2$	Length of column from the point of contraflexure to the bottom of column	$P_{dl}$	Axial dead load in the column / pile
$L_c$	Bent cap overhang length	$PI$	Plasticity Index (AASHTO T89, T90 or ASTM D 4318)
$L_p$	Analytical plastic hinge length	$P_{max}$	The maximum allowable axial load in the column, pile, or pier wall
$L_{p1}$	Analytical plastic hinge length of the first cantilever segment	$PGA_{B-C}$	Peak ground acceleration at B-C boundary
$L_{p2}$	Analytical plastic hinge length of the second cantilever segment	$R$	Force reduction factor obtained by dividing the spectral force by the plastic capacity
$L_{pr}$	Plastic hinge region	$R_D$	Reduction factor for higher damping ratio
$L_y$	Distance from top of column, pile or drilled shaft to the point of fixity used in the MSA model or the top of footing for bents with pile footings	$R_{DL}$	Dead load girder reaction
$M_{max}$	Maximum moment for the section (could be equal to the ultimate moment)	$R_T$	Displacement magnification factor to account for short period structures
$M_{ne}$	Nominal moment capacity of a reinforced concrete member based on expected materials properties	$S$	The skew angle of the bridge substructure measured from a line normal to the span
$M_p$	Plastic moment capacity of column, pile or drilled shaft	$S_l$	The mapped design spectral acceleration for the 1-second period as provided by the Regional Production Group's Geotechnical Design Squad (GDS) for the SEE or FEE
		$S_a$	Design spectral response acceleration for SEE or FEE corresponding to a given period ( $T_a$ )

$S_{DI}$	Design spectral response acceleration parameter at one second for the SEE or FEE	$b_b$	Cap or footing width
$S_{DS}$	Design short period (0.2 second) spectral response acceleration parameter for the SEE or FEE	$b_{je}$	Effective joint width
$S_s$	The mapped design spectral acceleration for the short period (0.2 second) as provided by the Regional Production Group's Geotechnical Design Squad (GDS) for the SEE or FEE	$c$	Damping ratio (enter in decimal format) maximum of 0.10
$T$	Fundamental period of the structure	$d_{bl}$	Longitudinal reinforcement nominal bar diameter
$T_o$	Period of peak acceleration for the structure (seconds)	$d_c$	Diameter of core measured to outside of transverse reinforcement
$T_a$	Period of SEE or FEE (seconds)	$d_e$	Depth of the member (80% of member depth in the direction of the shear)
$T_i$	Natural period of the less flexible frame or unit	$f_c$	Stress in concrete
$T_j$	Natural period of the more flexible frame or unit	$f'_c$	Specified concrete compressive strength
$T_s$	Period of acceleration degradation (seconds)	$f'_{cc}$	Peak stress of confined concrete
$T^*$	Characteristic ground motion period corresponding to the peak energy input spectrum	$f'_{ce}$	Expected maximum concrete compressive strength
$V_{ab}$	Shear strength of anchor bolts	$f_h$	Average axial horizontal stress
$V_{bw}$	Shear strength of the backwall	$f'_l$	Effective lateral confining stress
$V_c$	Concrete shear capacity	$f_{pc}$	Axial compressive stress in the concrete due to prestress alone, after all prestress losses considered
$V_p$	Plastic hinge shear force	$f_{ps}$	Prestressing steel stress
$V_{po}$	Overstrength plastic hinge shear force	$f_s$	Reinforcement steel stress
$V_s$	Reinforcement shear strength capacity	$f_{ue}$	Expected ultimate tensile strength of reinforcement steel
$V_{sk}$	Shear strength of the shear key	$f_v$	Average axial vertical stress
$V_u$	Smaller of elastic shear force or the overstrength plastic hinge shear force ( $V_{po}$ )	$f_y$	Specified minimum yield strength of reinforcement steel
$Y$	Pile embedment into cap or footing	$f_{ye}$	Expected yield strength of reinforcement steel
$Z_{DTM}$	Depth-to-motion is the location where the ground motion transmits the ground shaking energy to the structure.	$f_{yh}$	Transverse reinforcement expected yield stress
$a_p$	Pile width	$h$	Height from MSA point of fixity to top of column
		$h_b$	Cap or footing depth

$h_c$	Width of column	$s'$	Clear spacing between spirals or hoops
$h_{rt}$	Total elastomer thickness	$\bar{s}_u$	Average undrained shear strength for cohesive soils in the upper 100 ft (30 m) below $Z_{DTM}$ . (psf or kPa) (AASHTO T208 or T296 or ASTM D2166 or D2850)
$k_{bw}$	The secant or elastic backwall/wingwall stiffness as computed in Section 5.6.2	$v_{jh}$	Average joint shear stress
$k_{bw}^e$	Elastic backwall or wingwall stiffness	$\bar{v}_s$	Average shear wave velocity for the upper 100 ft (30 m) below $Z_{DTM}$ . (ft/sec or m/sec)
$k_{bw}^s$	Secant stiffness of backwall or wingwall	$w$	Moisture Content (AASHTO T265 or ASTM D 2216)
$k_e$	Confinement effectiveness coefficient	$w_c$	Density of concrete
$k_{F1F1}$	Longitudinal bearing stiffness	$x$	Ratio of concrete strain to maximum strain
$k_{F2F2}$	Vertical stiffness	$y_y$	Estimated yield displacement of bi-linear P-Y Curve
$k_i^e$	The smaller effective bent or column stiffness	$\Delta_{bw}$	Estimated displacement demand of backwall or wingwall in the transverse or longitudinal direction
$k_j^e$	The larger effective bent or column stiffness	$\Delta_c$	Displacement capacity
$k_{pile}$	The secant or elastic pile stiffness as computed in Section 5.6.1	$\Delta_{c1}$	Displacement capacity of first cantilever segment
$k_{pile}^e$	Elastic pile stiffness from the bi-linear SSI model	$\Delta_{c2}$	Displacement capacity of second cantilever segment
$k_{pile}^s$	Secant pile stiffness	$\Delta_d$	Displacement demand
$k_{total}$	The total stiffness for the end bent spring in either the transverse or longitudinal direction	$\Delta_E$	Ultimate bearing elastic shear deformation capacity
$k_{ww}$	The secant or elastic wingwall stiffness as computed in Section 5.6.2	$\Delta_{eq}$	Seismic displacement demand of the long period frame on one side of the expansion joint
$l_{ac}$	Anchorage length for longitudinal column reinforcement	$\Delta_{Fmax}$	Backwall or wingwall displacement required to fully develop the ultimate backwall passive pressure
$m_i$	Tributary mass of column or bent (i)	$\Delta_L$	Longitudinal displacement
$m_j$	Tributary mass of column or bent (j)	$\Delta_{ot}$	Movement attributed to prestress shortening, creep, shrinkage and thermal expansion or contraction to be considered no less than one inch per 100 feet of bridge superstructure length between expansion joints
$p_c$	Principal compressive stress		
$p_t$	Principal tensile stress		
$p_y$	Estimated yield load for bi-linear P-Y Curve		
$r$	Modulus of elasticity ratio		
$s$	Transverse reinforcement spacing		



$\Delta_p$	Plastic displacement	$\epsilon_{su}$	Ultimate tensile strain of steel reinforcement
$\Delta_{p1}$	Plastic displacement capacity of first cantilever segment	$\epsilon_{su}^R$	Reduced ultimate tensile strain of steel reinforcement
$\Delta_{p2}$	Plastic displacement capacity of second cantilever segment	$\epsilon_{ye}$	Yield strain at expected yield stress of steel reinforcement
$\Delta_{pile}$	Estimated top of pile displacement	$\phi_{max}$	Curvature at maximum moment (could be equal to the ultimate curvature)
$\Delta_r$	The relative lateral offset between the point of contraflexure and the end of the plastic hinge	$\phi_p$	Idealized plastic moment curvature
$\Delta_v$	Vertical deflection of bearing from dead load	$\phi_{p1}$	Idealized plastic moment curvature of the first cantilever segment
$\Delta_y$	Yield displacement	$\phi_{p2}$	Idealized plastic moment curvature of the second cantilever segment
$\Delta_{y1}$	Yield displacement of the first cantilever segment	$\phi_{sh}$	Curvature at idealized onset of strain hardening
$\Delta_{y2}$	Yield displacement of the second cantilever segment	$\phi_u$	Curvature at failure, defined as the confined concrete strain reaching $\epsilon_{ccu}$ or the confinement reinforcement steel reaching the ultimate strain $\epsilon_{su}$
$\Delta_y^{pile}$	Estimated top of pile displacement at yield point of bi-linear model	$\phi_{u1}$	Curvature at failure of the first cantilever segment, defined as the confined concrete strain reaching $\epsilon_{ccu}$ or the confinement reinforcement steel reaching the ultimate strain $\epsilon_{su}$
$\Lambda$	Fixity factor for the column (1 for fixed-free and 2 for fixed-fixed) end conditions	$\phi_{u2}$	Curvature at failure of the second cantilever segment, defined as the confined concrete strain reaching $\epsilon_{ccu}$ or the confinement reinforcement steel reaching the ultimate strain $\epsilon_{su}$
$\alpha$	Concrete factor 0.72 for $f_c \leq 4,000$ psi and decreases 0.04 for every 1000 psi up to 8,000 psi.	$\phi_s$	Shear strength reduction factor
$\epsilon_c$	Concrete strain	$\phi_y$	Yield curvature
$\epsilon_{cc}$	Concrete strain at maximum confined concrete stress	$\phi_{y1}$	Yield curvature of the first cantilever segment
$\epsilon_{cu}$	Unconfined concrete strain at maximum stress	$\phi_{y2}$	Yield curvature of the second cantilever segment
$\epsilon_{ccu}$	Ultimate confined concrete compressive strain, defined as strain at first hoop fracture	$\gamma$	Live load factor typically zero for standard SCDOT bridges (unless otherwise instructed by Department)
$\epsilon_{cy}$	Yield strain for unconfined concrete	$\mu_c$	Ductility capacity
$\epsilon_{ps}$	Prestressing steel strain		
$\epsilon_{psu}$	Ultimate prestressing steel strain		
$\epsilon_s$	Reinforcement steel strain		
$\epsilon_{sh}$	Onset of strain hardening of steel reinforcement		
$\epsilon_{sp}$	Unconfined concrete spalling strain		

---

$\mu_d$	Ductility demand
$\mu_f$	Coefficient of friction
$\theta$	Subtended angle
$\theta_{Mmax}$	Rotation at maximum moment
$\theta_p$	Plastic rotation
$\theta_{p1}$	Plastic rotation of the first cantilever segment
$\theta_{p2}$	Plastic rotation of the second cantilever segment
$\theta_{sh}$	Rotation at idealized onset of strain hardening
$\theta_u$	Ultimate rotation
$\rho_{cc}$	Longitudinal reinforcement ratio
$\rho_s$	Volumetric ratio of transverse reinforcement
$\Psi$	Fixity factor for the column or pile, 6 for fixed-fixed and 3 for fixed-free end conditions

**Section 3**

**GENERAL REQUIREMENTS**

**SCDOT Seismic Design Specifications for Highway Bridges**



## TABLE OF CONTENTS

<b>SECTION 3 – GENERAL REQUIREMENTS .....</b>	<b>3-1</b>
3.1 SEISMIC DESIGN APPROACH.....	3-1
3.2 OPERATIONAL CLASSIFICATION (OC).....	3-1
3.3 GROUND MOTIONS AND DESIGN EARTHQUAKES .....	3-1
3.4 SEISMIC PERFORMANCE LEVELS AND PERFORMANCE OBJECTIVES .....	3-3
3.4.1 Seismic Performance Service Levels.....	3-3
3.4.2 Seismic Performance Damage Levels .....	3-3
3.5 SEISMIC DESIGN CATEGORY (SDC).....	3-6
3.6 SEISMIC DEMAND .....	3-6
3.7 SEISMIC CAPACITY OF STRUCTURAL COMPONENTS.....	3-8
3.8 SEISMIC DEMAND VS. STRUCTURAL CAPACITY .....	3-8
3.9 DESIGN REQUIREMENTS FOR SINGLE SPAN BRIDGES OR SDC A BRIDGES.....	3-8
3.10 DESIGN REQUIREMENTS FOR SDC B, C and D BRIDGES.....	3-8
3.11 DESIGN REQUIREMENTS FOR TEMPORARY BRIDGES AND STAGED CONSTRUCTION.....	3-8
3.12 DESIGN REQUIREMENTS FOR PEDESTRIAN BRIDGES.....	3-8
3.13 SEISMIC DESIGN FLOW CHARTS .....	3-8
3.13.1 Seismic Design Category A or Single Span Bridges.....	3-8
3.13.2 Seismic Design Category B .....	3-9
3.13.3 Seismic Design Category C .....	3-9
3.13.4 Seismic Design Category D.....	3-9



## SECTION 3 – GENERAL REQUIREMENTS

### 3.1 SEISMIC DESIGN APPROACH

All bridges shall be designed to withstand deformations imposed by the design earthquake. All structural components shall be designed to provide sufficient strength and/or ductility, with a reasonable amount of reserve capacity, to ensure collapse will not take place during the design earthquake. This is often referred to as Performance Based Design or Displacement Based Design.

The collapse limit state is defined as the condition where any additional deformation will potentially render a bridge incapable of supporting its self-weight. Structural failure or instability in one or more components usually characterizes collapse. All forces (axial, flexure, shear and torsion) and deformations (rotation and displacement) shall be considered when quantifying the collapse limit state.

Bridges shall be seismically designed so that inelastic deformation (damage) intentionally occurs in interior bent columns or interior bent piles at locations where damage can be readily inspected and repaired after an earthquake. See Section 6.3 and 6.4 for more information about the location of the plastic hinge. No damage is allowed in the piles of a pile footing.

Capacity design procedures are used to prevent damage from occurring in capacity protected elements such as bent caps, footings and footing piles, etc... Should this performance objective be unattainable, a different structural configuration or foundation type shall be considered.

There are two exceptions to this design philosophy for operational classification II and III bridges, as determined in Section 3.2. For interior pile bents, end bent piles and interior bent drilled shafts, some limited plastic deformation is permitted below the ground or water level, with approval of SCDOT's Regional Production Group (RPG) Structural Engineer, in consultation with the Structural Design Support Engineer. See Section 6.3 for more information about the location of the plastic hinge.

The second exception is with lateral spreading associated with liquefaction. Significant inelastic deformation is permitted in piles and shafts under a large design earthquake when lateral spread occurs, with approval of SCDOT's Regional Production Group (RPG) Structural Engineer, in consultation with the Structural Design Support Engineer.

For seismic design of cast-in-place columns and drilled shafts, see Section 8.

Superstructure components designed adequately using AASHTO LRFD Specifications for strength or service load combinations, and meeting the requirements of Section 8 of the Specifications, shall be assumed to perform elastically under a design earthquake.

### 3.2 OPERATIONAL CLASSIFICATION (OC)

The Operational Classification (OC) is determined based on the location of the structure, traffic volume, design life, and available detour options. Structures are classified as OC I, II, or III based on the criteria set forth in Table 3.1.

### 3.3 GROUND MOTIONS AND DESIGN EARTHQUAKES

The design earthquake ground motions are based on probabilities of exceedance for a nominal life expectancy of a bridge equal to 75 years. Two levels of earthquakes are typically considered in the design:

Functional Evaluation Earthquake (FEE) – defined as the ground shaking having a 15% probability of exceedance in 75 years (15%/75 year). This design earthquake is equivalent to the 10% probability of exceedance in 50 years (10%/50).

Safety Evaluation Earthquake (SEE) – defined as the ground shaking having a 3% probability of exceedance in 75 years (3%/75 year). This design earthquake is equivalent to the 2% probability of exceedance in 50 years (2%/50).

Table 3.2 lists the seismic analysis level required for a structure based on the Operational Classification and potential for soil liquefaction.

**Table 3.1 Bridge Operational Classification (OC)**

Operational Classification (OC)	Description
<b>I</b>	All bridges that are located on the Interstate system or along the following roads: <ul style="list-style-type: none"> <li>• US 17, US 378 from SC 441 east to I-95</li> <li>• I-20 Spur from I-95 east to US 76</li> <li>• US 76 from I-20 Spur east to North Carolina</li> </ul> Additionally all bridges that meet any of the following criteria: <ul style="list-style-type: none"> <li>• Structures that do not have detours</li> <li>• Structures with detours greater or equal to 15 miles</li> <li>• Structures with a design life greater than 75 years</li> </ul>
<b>II</b>	All bridges that do not have a bridge OC = I and meet any of the following criteria: <ul style="list-style-type: none"> <li>• A projected (20 years) ADT <math>\geq 500</math></li> <li>• A projected (20 years) ADT <math>&lt; 500</math>, with bridge length longer than 180' or individual span length larger than 60'</li> </ul>
<b>III</b>	All bridges that do not have an OC = I or II classification.

**Table 3.2 Bridge Seismic Analysis Requirements**

Operational Classification (OC)	Analysis Description ♦
<b>I, II</b>	Seismic analysis shall be performed for the following design earthquakes: <ul style="list-style-type: none"> <li>• Functional Evaluation Earthquake (FEE) only when potential liquefiable soil or slope instability (see Geotechnical Design Manual for more information) exists and no geotechnical mitigation is performed.</li> <li>• Safety Evaluation Earthquake (SEE)</li> </ul>
<b>III</b>	Seismic analysis required for Safety Evaluation Earthquake (SEE) only.

♦ For design requirements of temporary bridges and staged construction, see Section 3.11. For design requirements for pedestrian bridges, see Section 3.12.

Detailed seismic analysis is not required for SDC A or Single Span bridges, however minimum detailing shall be provided, see Section 3.13.1.



### 3.4 SEISMIC PERFORMANCE LEVELS AND PERFORMANCE OBJECTIVES

All bridge systems shall be designed to meet the seismic performance objectives expressed in terms of service level and damage level. There are three bridge seismic performance service levels and three bridge seismic performance damage levels.

Structures are required to meet specific bridge seismic performance levels based on the OC and seismic analysis level. Table 3.3 lists the required bridge seismic performance service objectives.

All structure components shall be designed to meet the bridge seismic performance damage level objectives shown in Table 3.4. Since damages in end bent wing walls can be readily inspected and repaired, significant damages to wing walls are permitted.

The seismic performance levels and performance objectives are achieved by controlling the ductility demand imposed on the structure. See Section 7 for the ductility limits.

The performance objectives specified in Tables 3.3 and 3.4 are for new construction and do not apply to seismic retrofitting of structures. These objectives have been developed based on SCDOT design and construction standards of practice. SCDOT reserves the right to change these performance objectives based on project specific requirements or as new research or experience becomes available. The performance objectives are minimum requirements based on typical structures used in South Carolina. The designer of record, with concurrence of SCDOT's Regional Production Group (RPG) Structural Engineer, in consultation with the Structural Design Support Engineer, may impose more restrictive performance objectives and limits depending on the type of structure and operational classification. The designer of the structure has the ultimate responsibility to insure performance objectives are used judiciously so as not to jeopardize the structure being designed.

#### 3.4.1 Seismic Performance Service Levels

The three bridge seismic performance service levels are as follows:

**Immediate** Full access to all traffic immediately following the earthquake.

**Maintained** Immediate access to emergency traffic. Short period of closure to public with access typically restored within days of the earthquake.

**Impaired** Extended closure to public with access typically restored within months to years after the earthquake.

#### 3.4.2 Seismic Performance Damage Levels

The three bridge seismic performance damage levels are as follows:

**Minimal** No risk of collapse. Essentially elastic performance of structure with no permanent deformation.

**Repairable** No risk of collapse. Concrete cracking, spalling of concrete cover, and minor yielding of reinforcement steel will occur. The extent of damage is expected to be sufficiently limited so that the structure can be essentially restored to its pre-earthquake condition without replacement of reinforcement or replacement of structural members. Damage can be repaired with a minimum risk of losing functionality.

**Significant** Minimum risk of collapse. Permanent offsets may occur in elements other than foundations. Damage consisting of concrete cracking, reinforcement yielding, major spalling of concrete, and deformations in minor bridge components may require closure to repair. Partial or complete demolition and replacement may be required in some cases.

**Table 3.3 Bridge System (Global) Seismic Performance Objectives<sup>1</sup>**

Design Earthquake	Performance Level	Operational Classification (OC)		
		I	II	III
Functional Evaluation Earthquake (FEE <sup>2</sup> )	Service	Immediate	Maintained	See Note 2
	Damage	Minimal	Repairable	See Note 2
Safety Evaluation Earthquake (SEE)	Service	Maintained	Impaired	Impaired
	Damage	Repairable	Significant	Significant

1. Higher level seismic performance objectives may be required by SCDOT.
2. Analysis for FEE not required for OC III bridges

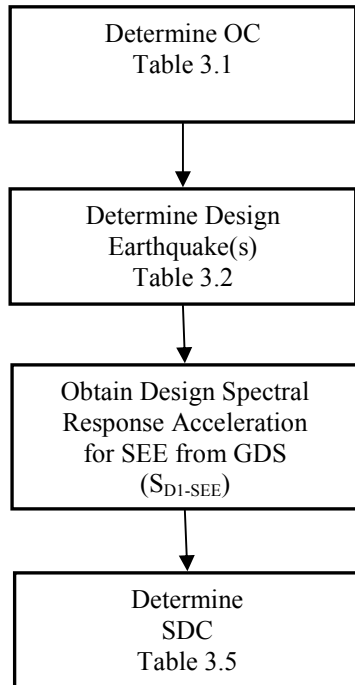
**Table 3.4 Bridge Components (Local) Damage Level Objectives**

Bridge Component		Design Earthquake	Operational Classification (OC)		
			I	II	III
Superstructure	FEE <sup>4</sup>	Minimal	Minimal	See Note 4	
	SEE	Minimal	Minimal	Minimal	
Connection Components <sup>1</sup>	FEE <sup>4</sup>	Repairable	Repairable	See Note 4	
	SEE	Significant	Significant	Significant	
Interior Bent Restraint Components <sup>2</sup>	FEE <sup>4</sup>	Minimal	Minimal	See Note 4	
	SEE	Minimal <sup>5</sup>	Minimal <sup>5</sup>	Minimal <sup>5</sup>	
End Bent Restraint Components <sup>2</sup>	FEE <sup>4</sup>	Minimal	Minimal	See Note 4	
	SEE	Significant	Significant	Significant	
Capacity Protected Components <sup>3</sup>	FEE <sup>4</sup>	Minimal	Minimal	See Note 4	
	SEE	Minimal	Minimal	Minimal	
Substructure	Single Column Bents	FEE <sup>4</sup>	Minimal	Repairable	See Note 4
		SEE	Repairable	Significant	Significant
	Multi Column Bents	FEE <sup>4</sup>	Minimal	Repairable	See Note 4
		SEE	Repairable	Significant	Significant
	End Bent Piles	FEE <sup>4</sup>	Minimal	Repairable	See Note 4
		SEE	Minimal	Significant	Significant
	End Bent Wing Walls	FEE <sup>4</sup>	Minimal	Repairable	See Note 4
		SEE	Significant	Significant	Significant
	Pile Bents	FEE <sup>4</sup>	Minimal	Repairable	See Note 4
		SEE	Repairable	Significant	Significant
	Pier Walls Weak Axis	FEE <sup>4</sup>	Minimal	Repairable	See Note 4
		SEE	Repairable	Significant	Significant
	Pier Walls Strong Axis	FEE <sup>4</sup>	Minimal	Minimal	See Note 4
		SEE	Minimal	Minimal	Repairable

1. Include Expansion Joints and Bearings
2. Include Shear Keys, Retainer Blocks, Anchor Bolts, Dowel Bars
3. Include Bent Caps, Footings, Oversized Shafts
4. Analysis for FEE Not Required for OC III Bridges
5. When shear keys are designed not to fuse

### 3.5 SEISMIC DESIGN CATEGORY (SDC)

Bridges are assigned a Seismic Design Category (SDC) based on the operational classification and the design SEE acceleration coefficient at one-second period ( $S_{D1-SEE}$ ). There are four Seismic Design Categories, SDC A through SDC D. Table 3.5 lists the SDC based on the OC and  $S_{D1-SEE}$ . Use the flow chart in Figure 3.2 to determine the SDC for a structure.



(GDS Stands for Regional Production Group Geotechnical Design Squad)

**Figure 3.1 Flow Chart to Determine SDC**

**Table 3.5 Seismic Design Category (SDC)**

Value of $S_{D1-SEE}$	Operational Classification (OC)		
	I	II	III
$S_{D1-SEE} < 0.30g$	B	A	A
$0.30g \leq S_{D1-SEE} < 0.45g$	C	B	A
$0.45g \leq S_{D1-SEE} < 0.60g$	C	C	B
$S_{D1-SEE} \geq 0.60g$	D	C	B

### 3.6 SEISMIC DEMAND

Seismic demand includes displacement demand and force demand.

Displacement demand can be obtained from a Multimode Spectral Analysis (MSA). This procedure is described in Section 5.2. Section 5 covers displacement demand modeling and computations. Upper limits of the displacement demand are given in Table 3.6. If displacement performance limits are exceeded, the designer shall consider other types of substructure configurations or change bridge geometry.

The design force demand is obtained from the MSA or the overstrength capacity of the ductile components, depending on the displacement demand of the structure.

If the displacement demand of the structure is less than the yield displacement, the force demand can be directly obtained from the MSA.

If the displacement demand is greater than the yield displacement, the MSA should not be used to obtain force demand. The force demand from the MSA in this situation does not recognize the force limit state associated with yield and computes unrealistic moment and shear demand. In this situation, the force demand is computed from the overstrength capacity of the ductile components as described in Section 6.7.5.

**Table 3.6 Bridge System Seismic Displacement Performance Limits<sup>♦</sup>**

Bridge System	Design Earthquake	Operational Classification (OC)		
		I	II	III
Expansion Joints (Longitudinal Differential Displacement) (inches) <sup>1</sup>	FEE <sup>3</sup>	0.015L	0.020L	See Note 3
	SEE	0.025L	0.040L	0.050L
Expansion Joints (Transverse Differential Displacement)	FEE <sup>3</sup>	2"	4"	See Note 3
	SEE	4"	6"	8"
Integral/Semi-Integral End Bents (Longitudinal Displacement)	FEE <sup>3</sup>	2"	4"	See Note 3
	SEE	4"	8"	12"
Integral/Semi- Integral End Bents (Transverse Displacement)	FEE <sup>3</sup>	2"	4"	See Note 3
	SEE	4"	8"	12"
Free Standing End Bents (Longitudinal Displacement)	FEE <sup>3</sup>	1"	2"	See Note 3
	SEE	3"	6"	8"
Free Standing End Bents (Transverse Displacement)	FEE <sup>3</sup>	2"	4"	See Note 3
	SEE	4"	8"	12"
Interior Bents – Fixed Bearings (Longitudinal Displacement) (inches) <sup>2</sup>	FEE <sup>3</sup>	0.075H	0.100H	See Note 3
	SEE	0.300H	0.400H	0.500H
Interior Bents – Expansion Bearings (Longitudinal Displacement) (inches) <sup>2</sup>	FEE <sup>3</sup>	0.050H	0.075H	See Note 3
	SEE	0.200H	0.300H	0.400H
Interior Bents (Transverse Displacement) (inches) <sup>2</sup>	FEE <sup>3</sup>	0.075H	0.100H	See Note 3
	SEE	0.250H	0.400H	0.500H

<sup>1</sup> "L" is the total expansion length at the joint. "L" shall be input in feet, with the results being in inches.

<sup>2</sup> The displacements are measured at the top of bents. "H" is the height measured from top of cap to top of footing, or point of fixity of drilled shaft/driven pile. Input "H" in feet, with the result being in inches.

<sup>3</sup> FEE not required for OC III bridges.

<sup>♦</sup> Displacement limits shall not exceed the minimum support length as described in Section 9.1.

### **3.7 SEISMIC CAPACITY OF STRUCTURAL COMPONENTS**

Moment-curvature analysis shall be used to calculate the strength and deformation capacity of ductile components. A ductile member is defined as any member that is intentionally designed to deform inelastically for several cycles without significant degradation of strength or stiffness under the demands generated by the design earthquake. Modeling and analysis of the structure to obtain displacement capacity is covered in Section 6.

### **3.8 SEISMIC DEMAND VS. STRUCTURAL CAPACITY**

In general, each bridge system and its components shall have sufficient capacity to resist seismic demands. See Section 7 for comparing seismic demand to structural capacity.

### **3.9 DESIGN REQUIREMENTS FOR SINGLE SPAN BRIDGES OR SDC A BRIDGES**

A detailed seismic analysis is not required for a single span bridge or for a bridge with SDC A, although the potential for liquefiable soil or slope stability shall still be investigated. Minimum support length shall be provided as detailed in Section 9.1.1. Connection and restraint components between the superstructure and substructure shall be designed in accordance with Sections 8.1, 9.2, and 9.4.

### **3.10 DESIGN REQUIREMENTS FOR SDC B, C and D BRIDGES**

For bridges with SDC B and above, a detailed seismic analysis is required to determine seismic demands and capacities of the bridge. Methods for computing demands and capacities are covered under Sections 5 and 6. Sections 8 and 9 cover detailing and design requirements for the bridge components.

### **3.11 DESIGN REQUIREMENTS FOR TEMPORARY BRIDGES AND STAGED CONSTRUCTION**

The requirement that an earthquake shall not cause collapse of all or part of a bridge applies to temporary bridges and detour bridges that are expected to carry traffic and/or pass over routes that carry traffic. Bridges that are constructed in stages and are expected to carry traffic and/or pass over routes that carry traffic must also satisfy these requirements. However, in view of the limited exposure period, the acceleration coefficient given in the FEE will be used

in order to calculate the structural component elastic forces and displacements during the stages of construction.

The minimum support length provisions of Section 9 shall be applied to temporary bridges and staged construction based on the bridge SDC.

A bridge or partially constructed bridge expected to be temporary for more than 5 years shall be designed using the requirements for permanent structures.

The widening of an existing structure is not covered by these Specifications. Existing structures undergoing the widening process may require seismic retrofitting to meet ductility and maximum displacement requirements and is covered on a case-by-case basis by the Department.

### **3.12 DESIGN REQUIREMENTS FOR PEDESTRIAN BRIDGES**

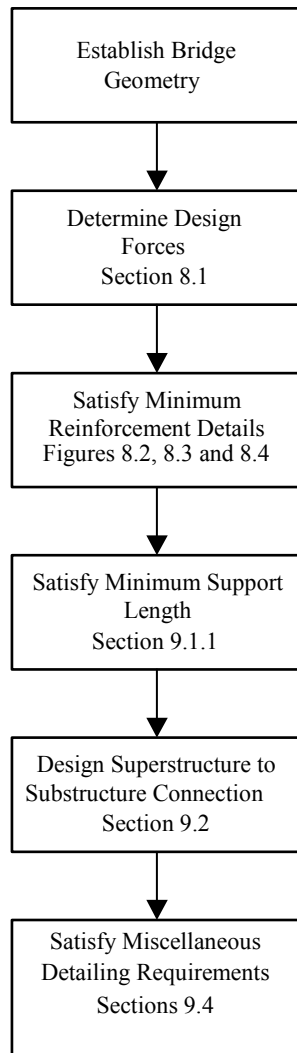
Pedestrian bridges over roads carrying vehicular traffic shall satisfy OC III performance objectives and shall be designed accordingly.

### **3.13 SEISMIC DESIGN FLOW CHARTS**

The following sub-sections detail the suggested design process for the four different bridge Seismic Design Categories.

#### **3.13.1 Seismic Design Category A or Single Span Bridges**

A structure designated SDC A or a single span structure does not require a check of seismic displacement demand, capacity or ductility. The main consideration shall be the minimum support length in both directions, superstructure to substructure connection and minimum detailing requirements of Sections 8 and 9. See Figure 3.3 for the SDC A analysis and design flowchart. This flow chart is also applicable to single span bridges.



**Figure 3.2 Flow Chart for SDC A and Single Span Bridges**

### 3.13.2 Seismic Design Category B

Detailed multi-mode spectral analysis model(s) will be required to determine the seismic displacement demand of the structure. The seismic yield displacement and displacement capacity of the structure designated SDC B can be estimated using explicit equations as prescribed in Section 6.5.3. See Figure 3.4 for the analysis and design flowchart. In addition, the minimum support length (Section 9.1) and pile/column to cap connection requirements (Section 8) apply to this type structure as well.

### 3.13.3 Seismic Design Category C

Detailed multi-mode spectral analysis model(s) will be required to determine the global seismic displacement demand of the structure. With the

likelihood of high seismic displacements and plastic deformations, the displacement capacity of the structure shall be determined using pushover analysis. See Figure 3.5 for the analysis and design flowchart. Similar to SDC B bridges, the minimum support length (Section 9.1) and pile/column to cap connection requirements (Section 8) apply to this type structure as well.

### 3.13.4 Seismic Design Category D

The analysis procedures for determining the seismic displacement and capacity are similar to those for structures designated SDC C. The difference is that in addition to the global displacement demand of the structure, the individual unit/frame (local) displacements shall be determined through stand-alone analysis. See Figure 3.6 for the analysis and design flowchart. In addition, the minimum support length (Section 9.1) and pile/column to cap connection requirements (Section 8) apply to this type structure as well.

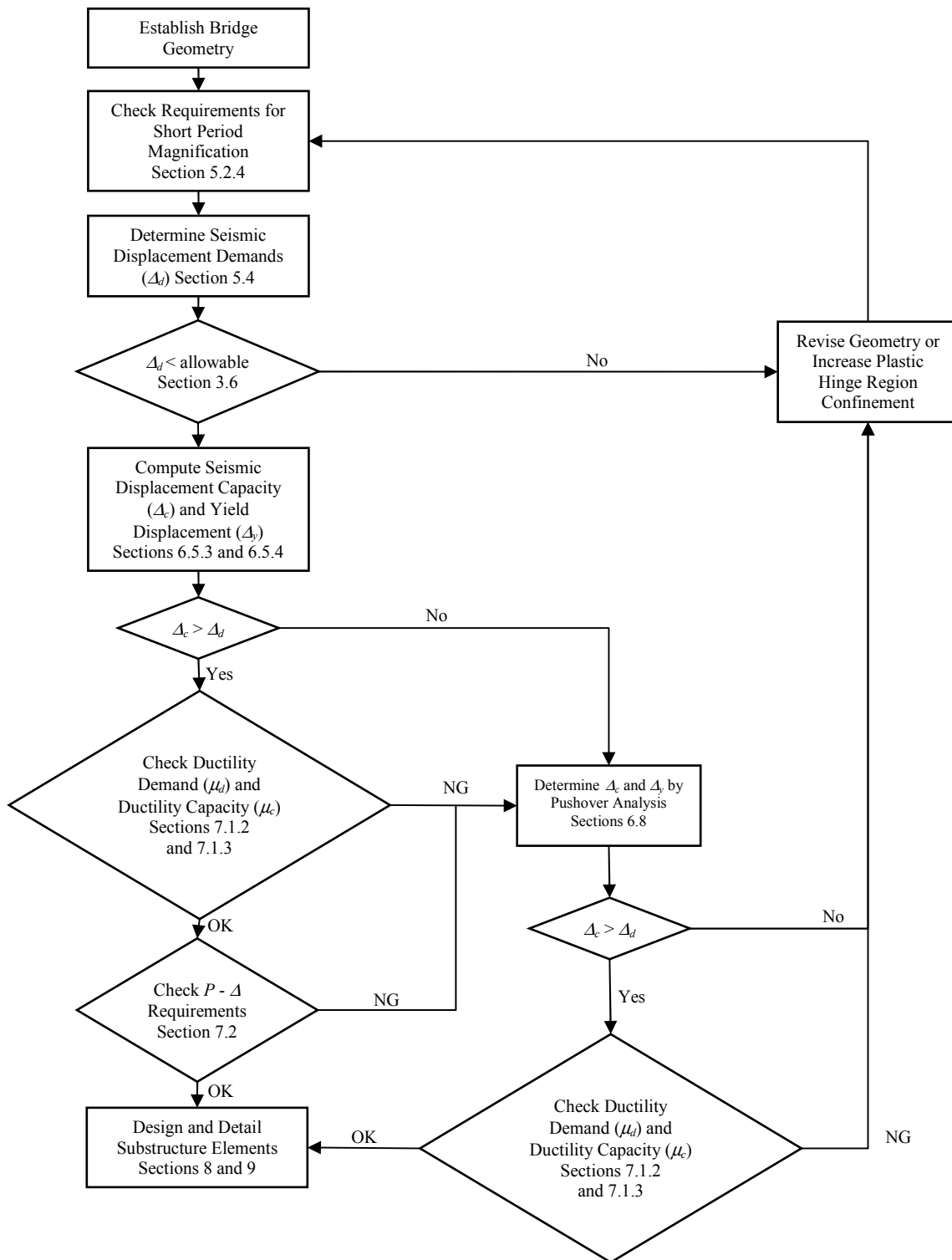


Figure 3.3 Flow Chart for SDC B



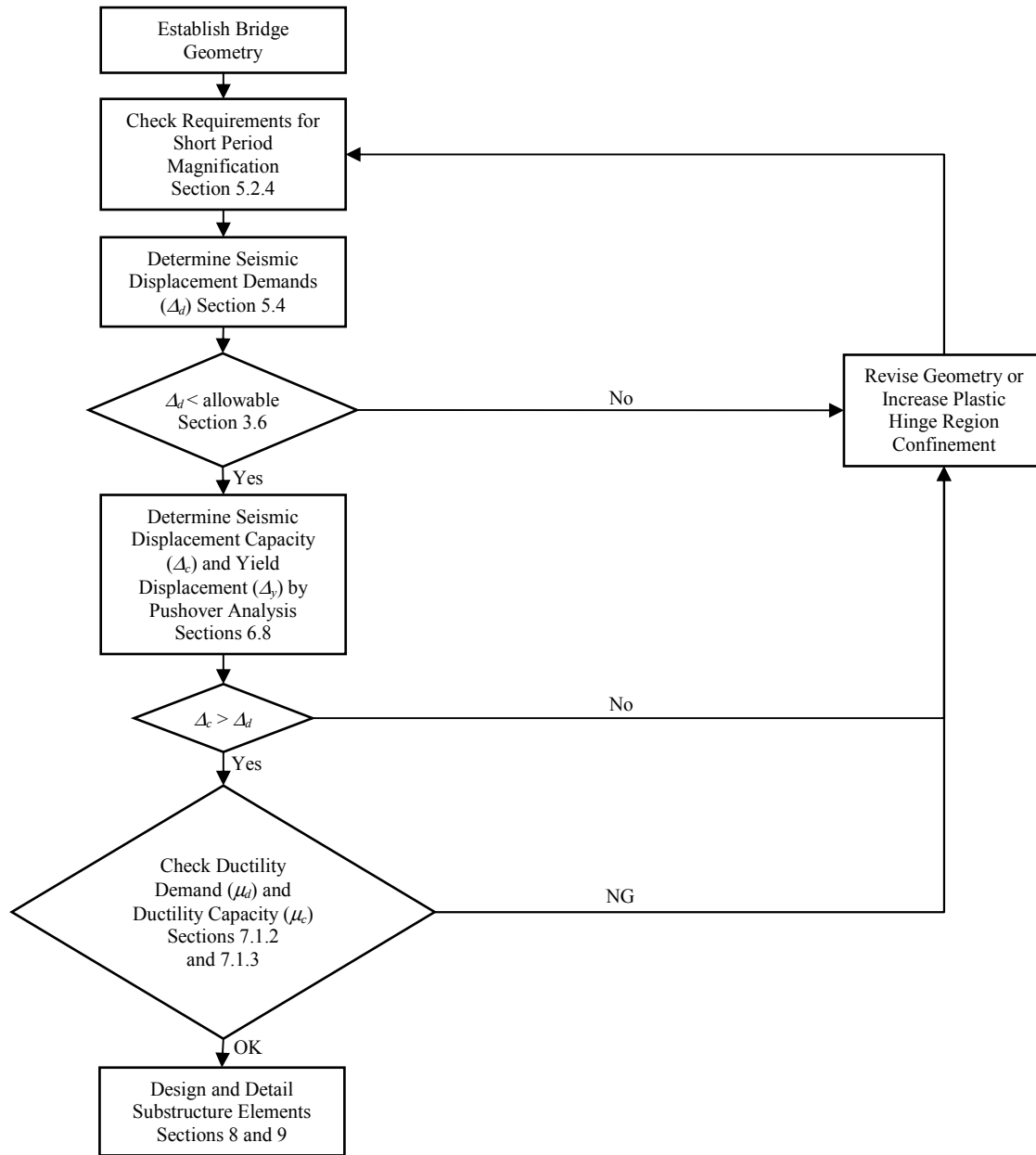


Figure 3.4 Flow Chart for SDC C

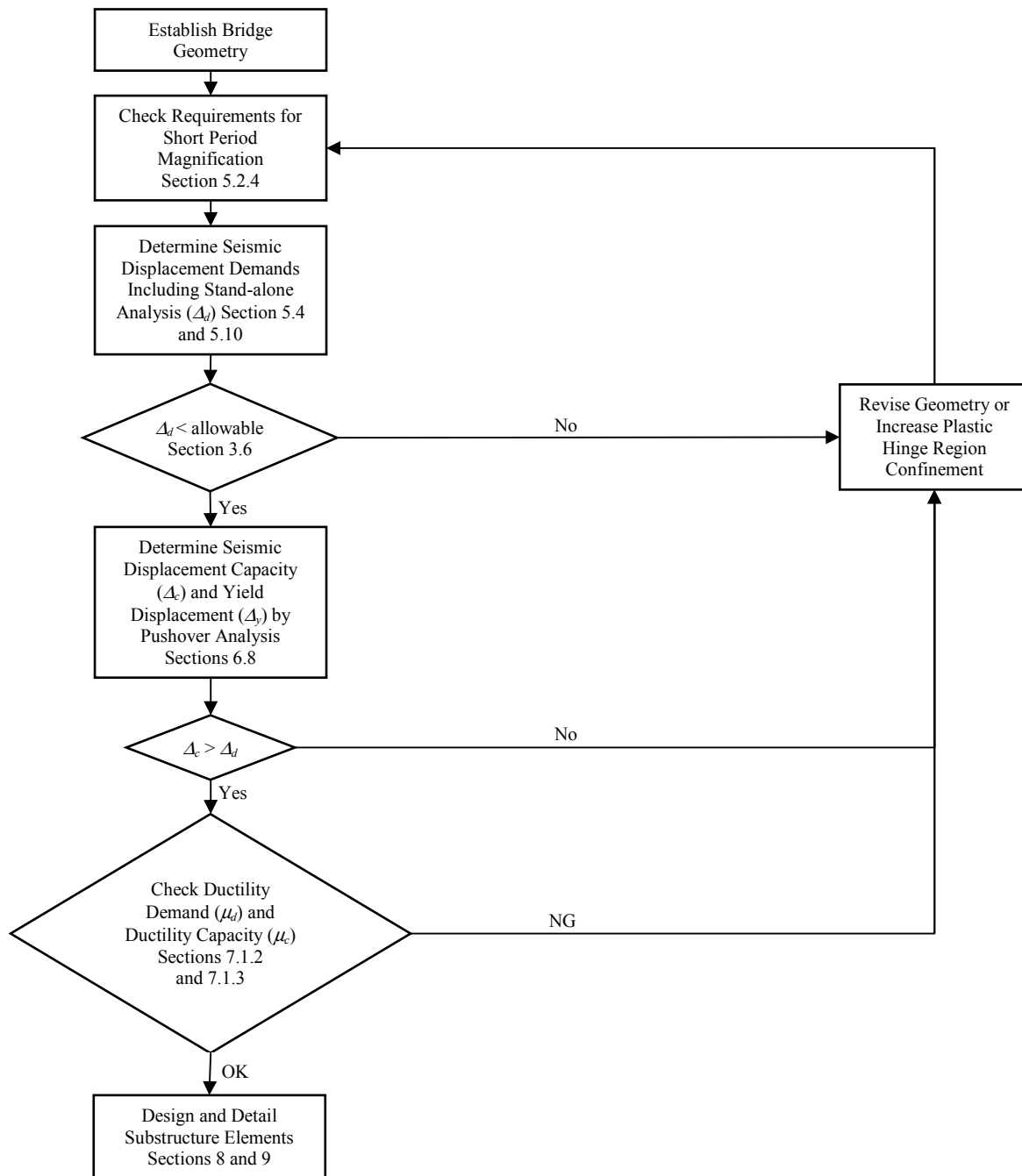


Figure 3.5 Flow Chart for SDC D

## **Section 4**

# **SEISMICITY, GEOTECHNICAL AND FOUNDATION DESIGN CONSIDERATIONS**

**SCDOT Seismic Design Specifications for Highway Bridges**



**TABLE OF CONTENTS**

**SECTION 4 – SEISMICITY, GEOTECHNICAL AND FOUNDATION DESIGN**

**CONSIDERATIONS .....4-1**

4.1 INTRODUCTION .....4-1

    4.1.1 SOUTH CAROLINA GEOLOGY .....4-1

    4.1.2 SOUTH CAROLINA SEISMICITY .....4-1

4.2 SITE CLASSIFICATION.....4-3

4.3 DESIGN EARTHQUAKE GROUND MOTIONS .....4-3

4.4 DESIGN RESPONSE SPECTRUM BASED ON GENERAL PROCEDURES.....4-5

4.5 SITE-SPECIFIC RESPONSE SPECTRUM.....4-6

4.6 DESIGN EARTHQUAKE ACCELERATION TIME HISTORIES .....4-6

4.7 LIQUEFACTION .....4-7

4.8 VERTICAL SETTLEMENT .....4-7

4.9 EMBANKMENT SLOPE STABILITY .....4-7

4.10 SPECIAL PILE REQUIREMENTS .....4-7

4.11 END BENTS.....4-8

    4.11.1 Free Standing End Bents and Retaining Walls .....4-8

    4.11.2 Integral/Semi-integral End Bents.....4-8

    4.11.3 Design Requirements for End Bents.....4-8

4.12 SEISMIC HAZARD MITIGATION .....4-9



## SECTION 4 – SEISMICITY, GEOTECHNICAL AND FOUNDATION DESIGN CONSIDERATIONS

### 4.1 INTRODUCTION

#### 4.1.1 SOUTH CAROLINA GEOLOGY

South Carolina has in the interior, the Appalachian Mountains, with an average elevation of 3,000 feet, followed by the Appalachian Piedmont that ranges in elevation from 300 feet to 1000 feet. Continuing eastward from these highlands is a "Fall Line" which serves to transition into the Atlantic Coastal Plain. The Atlantic Coastal Plain gently slope towards the Atlantic Ocean with few elevations higher than 300 feet. See Figure 4.1 for illustration. The sediment thickness in the coastal plain varies from 300 feet to 3,300 feet, which presents a unique geology for South Carolina and results in significantly different seismic hazards from those described in the USGS Seismic Hazard Maps. See Figure 4.2 for the coastal plain sediment thickness in the State of South Carolina.

In order to account for the actual geological conditions in South Carolina, a probabilistic seismic hazard study has been performed for South Carolina by SCDOT.



Figure 4.1 SC Geographic Regions

#### 4.1.2 SOUTH CAROLINA SEISMICITY

Even though seismically active areas are generally considered to be in California and the Western United States, historical records indicate that there have been major seismic events in the Central and Eastern United States of equal or greater magnitude

and that have occurred over broader area. Of particular interest to South Carolina is the 1886 earthquake in Charleston, SC, estimated to have a moment magnitude ( $M_M$ ) of at least 7.3. Also of interest to the northwestern end of South Carolina is the influence of the New Madrid seismic zone, near New Madrid, Missouri, where historical records indicate that between 1811 and 1812 there were large earthquakes with an estimated maximum moment magnitude of 7.4.

Sources of seismicity are not well defined in much of the Eastern United States. Seismicity sources have therefore been defined based on seismic history in the Southeastern United States. A probabilistic seismic hazard study of South Carolina has been prepared for SCDOT. The South Carolina Earthquake Hazard study was based on two types of seismic sources defined as Non-Characteristic Earthquakes and Characteristic Earthquakes.

The newly developed South Carolina Seismic Hazard Maps shall be used for the seismic design of typical SCDOT bridges. For non-typical bridges the SCDOT Preconstruction Support/Geotechnical Design Section (PCS/GDS) in consultation with the RPG Geotechnical Design Squad, will specify and/or approve appropriate geotechnical earthquake engineering provisions on a project specific basis.

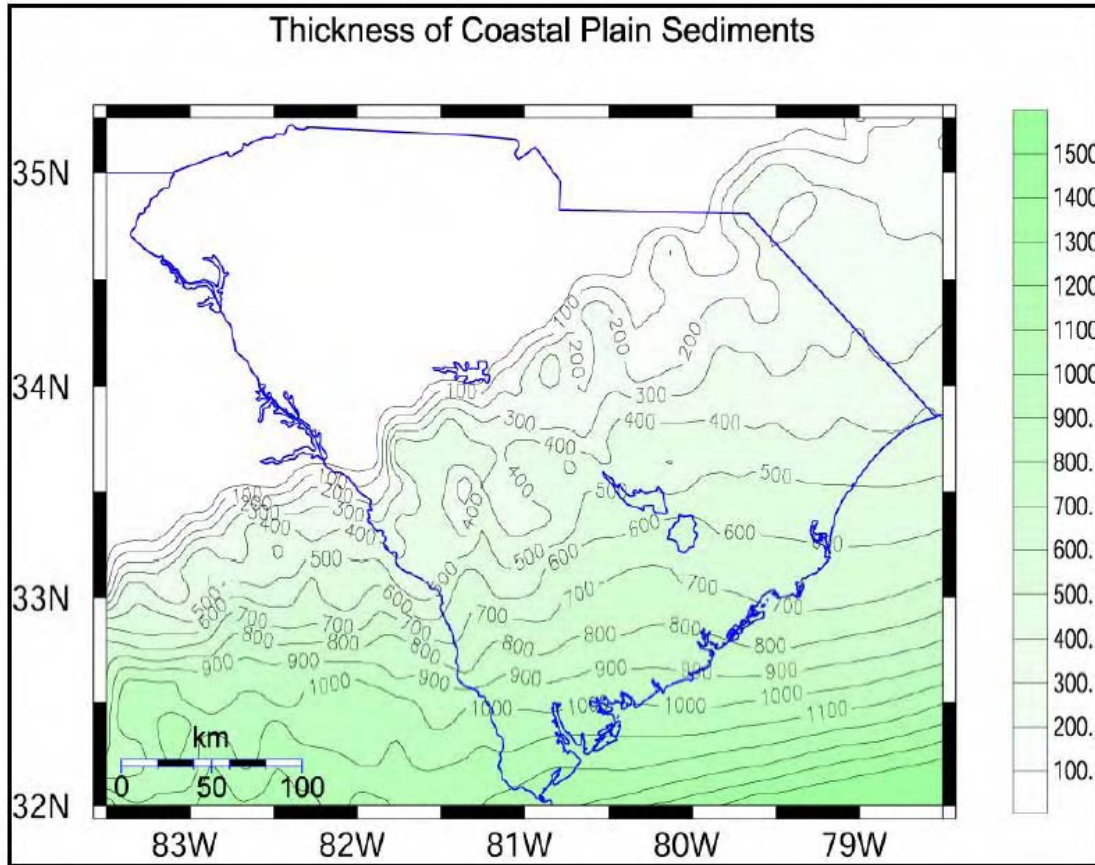


Figure 4.2 Coastal Plain Sediment Thickness



## 4.2 SITE CLASSIFICATION

There are six (6) site classes, see Table 4.1. They are classified by the site stiffness (average shear wave velocity). See Table 4.2 for the site classification parameters for each site class.

**Table 4.1 Site Classes**

Site Class	Soil Profile Name
A	Hard rock
B	Rock
C	Very dense soil and soft rock
D	Stiff Soil
E	Soft soil
F	Soil requiring site specific response spectrum evaluation

Site Class F soil contains one or more of the following characteristics:

1. Peats and/or highly organic clays ( $H > 10$  ft of peat and/or highly organic clay where  $H$  = thickness of soil)
2. Very high plasticity clays ( $H > 25$  ft with plasticity index larger than 75)
3. Very thick soft/medium stiff clays ( $H > 120$  ft)

The site class is dependant on the soil information obtained from subsurface investigations. The geotechnical engineer will evaluate the soil information and determine the site class. Detailed procedures of determining the site classes are given in the Geotechnical Design Manual (GDM).

## 4.3 DESIGN EARTHQUAKE GROUND MOTIONS

Two levels of design earthquake ground motions are identified in Section 3.3. These ground motions are the Safety Evaluation Earthquake (SEE) and the Functional Evaluation Earthquake (FEE). The ground motions required in the seismic analysis are set forth in Table 3.2, with the exception of staged construction or temporary structures as described in Section 3.11.

An Acceleration Design Response Spectrum (ADRS) represents the design earthquake ground motions. The ADRS shall be provided by the Regional Geotechnical Design Squad (GDS) using the procedures set forth in the GDM.

**Table 4.2 Site Class Category**

SITE CLASS	SOIL PROFILE NAME	AVERAGE PROPERTIES IN TOP 100 FT (30 M) Below $Z_{DTM}$
		SITE STIFFNESS $\bar{V}_s$
A	Hard Rock	$\bar{V}_s > 5,000$ ft/sec ( $\bar{V}_s > 1500$ m/sec)
B	Rock	$2,500 < \bar{V}_s \leq 5,000$ ft/sec ( $760 < \bar{V}_s \leq 1500$ m/sec)
C	Very Dense Soil and Soft Rock	$1,200 < \bar{V}_s \leq 2,500$ ft/sec ( $360 < \bar{V}_s \leq 760$ m/sec)
D	Stiff Soil	$600 \leq \bar{V}_s \leq 1,200$ ft/sec ( $180 \leq \bar{V}_s \leq 360$ m/sec)
E	Soft Soil	$\bar{V}_s < 600$ ft/sec ( $\bar{V}_s < 180$ m/sec)
		Any profile with more than 10 ft (3m) of soft clay defined as: $PI > 20$ ; $w \geq 40\%$ ; and $\bar{\tau} = \bar{s}_u < 500$ psf (25 kPa)
F	Soils Requiring Site Specific Response Evaluation	Any soil profile containing one or more of the following characteristics: 1. Peats and/or highly organic clays ( $H > 10$ ft [3 m] of peat and/or highly organic clay where $H$ = thickness of soil) 2. Very high plasticity clays ( $H > 25$ ft [8 m] with $PI > 75$ ) 3. Very thick soft/medium stiff clays ( $H > 120$ ft [36 m])

**Definitions:**  
 $PI$  = Plasticity Index (AASHTO T89, T90 or ASTM D 4318)  
 $w$  = Moisture Content (AASHTO T265 or ASTM D 2216)  
 $\bar{V}_s$  = Average shear wave velocity for the upper 100 ft (30 m) below  $Z_{DTM}$ . (ft/sec or m/sec)  
 $\bar{\tau}$  = Average undrained shear strength ( $\bar{\tau} = \bar{s}_u$ ) for cohesive soils in the upper 100 ft (30 m) below  $Z_{DTM}$ . (psf or kPa) (AASHTO T208 or T296 or ASTM D2166 or D2850)  
 $Z_{DTM}$  = Depth-to-motion is the location where the ground motion transmits the ground shaking energy to the structure.

**Notes:**

- (1) The shear wave velocity for rock, Site Class B, shall be either measured on site or estimated by a geotechnical engineer or engineering geologist/seismologist for competent rock with moderate fracturing and weathering. Softer and more highly fractured and weathered rock shall either be measured on site for shear wave velocity or classified as Site Class C.
- (2) The hard rock, Site Class A, category shall be supported by shear wave velocity measurements either on site or on profiles of the same rock type in the same formation with an equal or greater degree of weathering and fracturing. Where hard rock conditions are known to be continuous to a depth of 100 feet (30m) below  $Z_{DTM}$ , surficial shear wave velocity measurements may be extrapolated to assess shear wave velocities.
- (3) Site Classes A and B should not be used when there is more than 10 feet (3m) of soil between the rock surface and the depth-to-motion,  $Z_{DTM}$ . When rock is encountered within the 100 feet (30m) below the depth-to-motion,  $Z_{DTM}$ , and the soil layer is more than 10 feet (3m) use the Site Class pertaining to the soil above the rock.
- (4) A Site Class F is not required if a determination is made that the presence of such soils will not result in a significantly higher response of a bridge. Consideration of the effects of depth-to-motion,  $Z_{DTM}$ , shall be taken into account when making this determination. Such a determination must be approved by the PCS/GDS.

### 4.4 DESIGN RESPONSE SPECTRUM BASED ON GENERAL PROCEDURE

Detailed procedures of determining the Acceleration Design Response Spectrum (ADRS) are given in the GDM. The ADRS values are generated for a structure with 5% damping. For SCDOT in-house projects, the seismic hazard information, including ADRS can be obtained from the GDS following the procedures set forth in the GDM.

The SCDOT seismic hazard maps are developed to account for the actual geologic conditions, especially the thickness of the coastal plain deposits, see Figure 4.2. The base mapped PGA, and response spectral acceleration values ( $S_s$  and  $S_l$ ) from the maps, as obtained from the GDS, shall be modified by site class specific coefficients listed in Tables 4.3 and 4.4 using the following equations.

$$S_{DS} = F_a S_s \tag{4-1}$$

$$S_{DI} = F_v S_l \tag{4-2}$$

$$PGA = F_{PGA} PGA_{B-C} \tag{4-3}$$

Where:

$S_{DS}$  Design short period (0.2 second) spectral response acceleration parameter for the SEE or FEE

$S_{DI}$  Design spectral response acceleration parameter at one second for the SEE or FEE

$F_a$  Site coefficient defined in Table 4.3 based on the site class and the values of the mapped response acceleration parameter  $S_s$

$PGA$  Peak ground acceleration

$F_{PGA}$  Site coefficient for peak ground acceleration

$PGA_{B-C}$  The mapped peak ground acceleration at the B-C boundary (T=0 sec) as provided by the GDS for FEE and SEE.

$F_v$  Site coefficient defined in Table 4.4 based on the site class and the values of the mapped response acceleration parameter  $S_l$

$S_s$  The mapped spectral acceleration for the short period (0.2 second) as provided by the GDS for the SEE or FEE

$S_l$  The mapped spectral acceleration for the 1.0 second period as provided by the GDS for the SEE or FEE

**Table 4.3 Values of  $F_{PGA}$  and  $F_a$  as a Function of Site Class and Mapped Short-Period Spectral Response Acceleration  $S_s$**

Site Class	Mapped Peak Ground Acceleration ( $PGA_{B-C}$ ) or Spectral Acceleration ( $S_s$ ) at Short Periods				
	$PGA_{B-C} \leq 0.10$ $S_s \leq 0.25$	$PGA_{B-C} = 0.20$ $S_s = 0.50$	$PGA_{B-C} = 0.30$ $S_s = 0.75$	$PGA_{B-C} = 0.40$ $S_s = 1.00$	$PGA_{B-C} \geq 0.50$ $S_s > 1.25$
A	0.8	0.8	0.8	0.8	0.8
B	1.0	1.0	1.0	1.0	1.0
C	1.2	1.2	1.1	1.0	1.0
D	1.6	1.4	1.2	1.1	1.0
E	2.5	1.7	1.2	0.9	0.9
F	*	*	*	*	*

\* Site-specific geotechnical investigation and dynamic site response analysis shall be performed.

Linear interpolation may be performed for intermediate values of  $PGA_{B-C}$  or  $S_s$ , where  $PGA_{B-C}$  is the peak ground acceleration and  $S_s$  is the spectral acceleration coefficient at 0.2 second obtained from the ground motion maps.

**Table 4.4 Values of  $F_v$  as a Function of Site Class and Mapped Spectral Response Acceleration at 1.0 Second Period  $S_l$**

Site Class	Mapped Spectral Response Acceleration ( $S_l$ ) at 1.0 Second Period				
	$S_l < 0.10$	$S_l = 0.20$	$S_l = 0.30$	$S_l = 0.40$	$S_l > 0.50$
A	0.8	0.8	0.8	0.8	0.8
B	1.0	1.0	1.0	1.0	1.0
C	1.7	1.6	1.5	1.4	1.3
D	2.4	2.0	1.8	1.6	1.5
E	3.5	3.2	2.8	2.4	2.4
F	*	*	*	*	*

\* Site-specific geotechnical investigation and dynamic site response analysis shall be performed.

Linear interpolation may be performed for intermediate values of  $S_l$ , where  $S_l$  is the mapped spectral acceleration coefficient at 1.0 second obtained from the ground motion maps.

The general design response spectrum curve shall be developed as indicated in Figure 4.3 and as follows.

For periods less than or equal to  $T_o$  as defined using Equation 4-4, the design spectral response acceleration  $S_a$ , shall be given by Equation 4-5.

$$T_o = 0.2 \frac{S_{DI}}{S_{DS}} \tag{4-4}$$

$$S_a = PGA + (S_{DS} - PGA) \frac{T}{T_o} \tag{4-5}$$

Where:

- $S_a$  Design spectral response acceleration for SEE or FEE corresponding to a given period ( $T$ )
- $S_{D1}$  Design spectral response acceleration parameter at 1-second for the SEE or FEE
- $S_{DS}$  Design short period (0.2 second) spectral response acceleration parameter for the SEE or FEE
- $T$  Period of vibration (seconds)

For periods greater than or equal to  $T_o$  and less than or equal to  $T_s$  as defined using Equation 4-6, the design spectral response acceleration,  $S_a$ , shall be taken equal to  $S_{DS}$ .

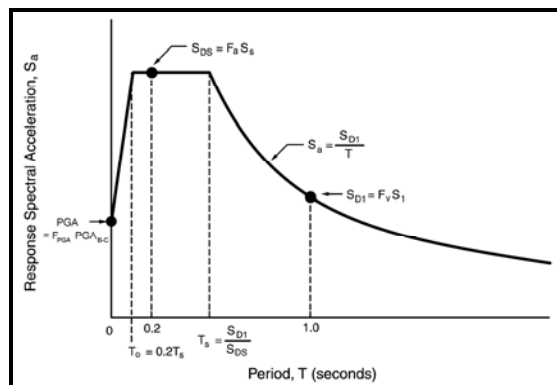
$$T_s = \frac{S_{D1}}{S_{DS}} \tag{4-6}$$

Where:

- $T_s$  Period of acceleration at the beginning of degradation (seconds)

For periods greater than  $T_s$ , the design spectral response acceleration,  $S_a$ , shall be given by Equation 4-7.

$$S_a = \frac{S_{D1}}{T} \tag{4-7}$$



**Figure 4.3 Design Response Spectrum**

The Multi-Point method of constructing an ADRS curve shall be used to check the reasonableness of the Three-Point ADRS curve. For constructing the Multi-Point ADRS curve, see the GDM. However, the Multi-Point method can lead to ambiguous results for sites other than rock because only a short-period site factor and a long-period site factor are available and it is not clear how the site factors vary when applied to spectral values at multiple periods.

Therefore, judgment shall be required when applying the multi-point method for soil sites other than rock.

#### 4.5 SITE-SPECIFIC RESPONSE SPECTRUM

A site-specific response analysis is required for bridges with a Site Class F, or when SCDOT Seismic Hazard Maps are not appropriate. Site-specific response analysis shall be based on the geologic, seismologic, and soil characteristics associated with the specific site. See the SCDOT Geotechnical Design Manual for procedures to determine site-specific response spectrum. The site-specific response analysis requirements and procedures specified in SCDOT Geotechnical Design Manual apply only to typical SCDOT bridges specified in Section 1.5. For non-typical bridges the SCDOT PCS/GDS in consultation with the Regional Production Group GDS, will specify and/or approve appropriate geotechnical earthquake engineering provisions on a project specific basis.

#### 4.6 DESIGN EARTHQUAKE ACCELERATION TIME HISTORIES

Typically non-linear time history analysis is required for non-typical SCDOT bridges or for bridges utilizing isolation bearings. When a time history analysis of a bridge is required, the time histories of ground motions to be used in the analysis should represent the seismic environment of the site and local site conditions. Site characteristics to be considered typically include:

- The tectonic environment, e.g., crustal environment in eastern United States
- Earthquake magnitude
- Type of faulting (e.g., strike-slip; reverse; normal)
- Seismic source-to-site distance
- Local site conditions
- Design or expected ground motion characteristics (e.g., design response spectrum, duration of strong shaking, special ground motion characteristics such as near-fault characteristics)

Typically, at least three time histories of either recorded, simulated-recorded, or spectrum-matched motions, should be used for each component of motion when performing non-linear inelastic dynamic analysis. However, due to lack of recorded time histories similar to SCDOT seismic hazard, a generated synthetic time history is used to perform time history analysis for SCDOT bridges based on

South Carolina Seismic Hazard Study. For more information and procedures of determining earthquake acceleration time histories, see the GDM.

#### 4.7 LIQUEFACTION

The effects of geotechnical seismic hazard shall be considered in the design of all bridges. A liquefaction potential assessment shall be conducted for soils that have been screened to be potentially liquefiable. The liquefaction potential shall be evaluated according to the procedures described in the GDM. If potential liquefaction at the project site may occur under seismic loading, consideration shall be given to the following:

- Bridges should be analyzed and designed for a liquefied and a non-liquefied configurations. For the non-liquefiable configuration, the structure should be analyzed with the appropriate ADRS assuming a no liquefied state for the site. The same ADRS used for the no liquefied condition should be used for the analysis and design of the liquefied condition. The structure should be analyzed and designed assuming that the layer has liquefied and the liquefied soil provides the appropriate residual resistance.
- The Designer should provide explicit detailing of plastic hinging zones for both cases, since it is likely that locations of plastic hinges for the liquefied configuration are different than locations of plastic hinges for the non liquefied configuration.
- Design requirements including shear reinforcement should be met for liquefied and non-liquefied configurations.
- Liquefaction induced soil settlement
- Liquefaction induced down drag forces
- Embankment slope stability
- Liquefaction induced lateral flow
- Liquefaction induced lateral spreading

The effect of liquefaction induced down drag can have a significant effect on the substructure. The additional load on the pile or column elements shall be considered in the design.

Coordination is required between the structural engineer and the geotechnical engineer in order to minimize the effect of soil liquefaction and adaptation of mitigation measures, such as ground modification, utilization of different substructure types, etc. to achieve an economical design.

#### 4.8 VERTICAL SETTLEMENT

Ground settlement due to soil consolidation can occur as liquefaction-induced, excess pore water pressure in the soil dissipates. This consolidation occurs over time, perhaps for several days after the earthquake, and may result in the settlement and/or differential settlement of foundations located above the liquefied layer.

The settlement of end bents and interior bents shall be considered in tandem with the lateral motions accompanying the design event. The vertical settlement of the substructure can result in additional load on substructure elements, increased rotation of bearing elements, uplift of continuous structures and excessive superstructure grade changes.

The geotechnical engineer is responsible for evaluating earthquake induced soil settlement in accordance with the SCDOT GDM.

#### 4.9 EMBANKMENT SLOPE STABILITY

The bridge embankment is defined as 150' from begin or end of the bridges in the longitudinal direction. Slope failure of the bridge embankment due to earthquake loads can lead to significant damage to end bent components or complete bridge failure.

Global stability of bridge embankments shall be determined utilizing the procedures prescribed in the SCDOT GDM.

#### 4.10 SPECIAL PILE REQUIREMENTS

Piles may be used to resist both axial and lateral loads. The minimum depth of embedment, together with the axial and lateral pile capacities, required to resist seismic loads shall be determined by means of the design criteria established in the site investigation report. Note, the ultimate capacity of the piles should be used in designing for seismic loads.

When reliable uplift pile capacity from skin friction is present, and the pile/footing connection detail and structural capacity of the pile are adequate, uplift at a pile footing is acceptable, provided the magnitude of footing rotation will not result in unacceptable performance. Friction piles may be considered to resist intermittent, but not sustained, uplift. For seismic loads, uplift resistance may be equivalent to 50 percent of the ultimate skin friction resistance. In no case shall the uplift exceed the weight of material (buoyancy considered) surrounding the embedded portion of the pile.

Timber piles, treated or untreated, are not allowed. All concrete piles shall be reinforced to resist the design moments, shears, and axial loads. Minimum pile reinforcement shall be in accordance with the SCDOT bridge drawings and details.

In soft soils, piles shall be designed and detailed to accommodate imposed seismic displacements and axial forces based on the results of the design earthquake analysis.

#### **4.11 END BENTS**

The participation of end bent walls in the overall dynamic response of bridge systems to earthquake loading and in providing resistance to seismically induced inertial loads shall be considered in the seismic design to reflect the structural configuration, the load-transfer mechanism from bridge to end bent system, the effective stiffness and force capacity of wall-soil systems, and the level of expected end bent damage. Seismic resistance from end bents shall not be considered on simply supported spans.

Under the earthquake loading, the earth pressure action on end bent walls changes from a static condition to one of two dynamic conditions. A dynamic active pressure condition, as the wall moves away from the backfill, and a dynamic passive condition as the bridge pushes the wall into the backfill.

The capacity of end bents to resist the bridge inertial load shall be compatible with the structural design of the end bent wall (i.e., whether part of the wall will be damaged by the design earthquake) as well as the soil resistance that can be reliably mobilized. Soil capacity shall be evaluated based on an applicable passive earth pressure theory for end bent walls. Active pressure and passive pressure methods of analysis shall be performed according to the appropriate methods presented on the GDM.

##### **4.11.1 Free Standing End Bents and Retaining Walls**

For free standing end bents and retaining walls which may displace horizontally without significant restraint and where the expansion joint is sufficiently large to accommodate both the cyclic movement between the abutment wall and the bridge superstructure, the seismically induced earth pressure on the abutment wall shall be considered the dynamic active pressure condition. However, when the gap at the expansion joint is not sufficient to accommodate the cyclic wall/bridge movements, a transfer of forces will occur from the superstructure to the end bent

wall. As a result, the active earth pressure condition will not be valid and the earth pressure approaches a much larger passive pressure load condition behind the backwall, which is the main cause for end bent damage (e.g., superstructure supported by sliding bearings).

On the evaluation of the earthquake induced active lateral forces, the Mononobe-Okabe method of analysis, should be used with caution because, it can give excessively high wall pressures and failure surfaces that approach infinity (flat) for high accelerations and walls with backslopes.

The seismic design of free-standing end bents should take into account forces arising from seismically-induced lateral earth pressures, additional forces arising from wall inertia effects and the transfer of seismic forces from the bridge deck through bearing supports which do not slide freely (e.g., elastomeric bearings).

For free standing end bents, which are restrained from horizontal displacement by anchors (such as MSE walls), the magnitudes of seismically induced lateral earth pressures are higher than those given by the Mononobe-Okabe method of analysis.

##### **4.11.2 Integral/Semi-integral End Bents**

For integral/semi integral end bents where the end bent forms an integral part of the bridge superstructure, the abutment stiffness and capacity under passive pressure loading are primary design concerns. The Mononobe-Okabe method for evaluating seismic passive capacity should not be used. To minimize end bent damage, the end bent should be designed to resist the passive pressure capable of mobilizing end bent backfill, which should be greater than the maximum estimated longitudinal earthquake force transferred to the end bent. It may be assumed that the lateral active earth pressure during seismic loading is less than the superstructure earthquake load.

When piers or columns at intermediate supports resist longitudinal seismic forces, it is necessary to estimate end bent stiffness in the longitudinal direction in order to compute the proportion of earthquake load resisted by the end bent.

##### **4.11.3 Design Requirements for End Bents**

In addition to the provisions in Sections 4.11.1 and 4.11.2, consideration should be given to the mechanism of transfer of superstructure transverse inertial forces to the bridge end bents. Adequate

resistance to lateral pressure should be provided by wing walls or end bent keys to minimize lateral end bent displacements where desired.

Damage to wing walls is allowed to occur during earthquakes considering the no collapse criteria. The lateral load capacity of the walls shall be evaluated based on an applicable passive earth-pressure theory. A simplistic approach that may be used is to consider one wall 2/3 effective in acting against the end bent soil fill, while the second wall is considered 1/3 effective in acting against the outside sloped berm.

To minimize potential loss of bridge access arising from end bent damage, monolithic or end diaphragm construction is strongly recommended for short span bridges.

Approach slabs providing structural support between approach fills and end bents shall be provided for all bridges classified as SDC B and above. Slabs shall be adequately linked to end bents using flexible ties.

The end bent skew should be minimized. Bridges with end bents having skews greater than 20° have a tendency for increased displacements at the acute corner. In the case where a skewed end bent cannot be avoided, sufficient support length in conjunction with an adequate shear key shall be designed to prevent any possible unseating of the bridge superstructure.

#### **4.12 SEISMIC HAZARD MITIGATION**

Ground improvement can be implemented to mitigate the effects of liquefaction. A number of these methods are available, including grouting (compaction, permeation, and jet), vibro systems (vibro probe, vibro-compaction, vibro-replacement), surcharge and buttress fills, reinforcement and containment (root piles, mixed-in-place walls and columns) and drains. The suitability of these methods will depend on the soil conditions at the site, the location of the ground water, and project logistics.

A critical phase in any ground improvement method is confirmation that the ground improvement goals have been achieved. Pre- and post field explorations are required using SPT or Cone Penetration Test (CPT) methods to confirm that required ground improvements have been achieved. It is desirable to conduct a test program prior to implementing an actual ground improvement program to confirm that the proposed improvement methods will work in the particular conditions occurring at the project site.

However, any ground improvement may result in significantly additional construction cost. The structural engineer shall work closely with the geotechnical engineer to explore other options (such as changing the bridge geometry, substructure type, etc...) to mitigate the seismic hazard before applying any ground improvement.

Prior approval by the SCDOT Preconstruction Support/Geotechnical Design Section (PCS/GDS) in consultation with the RPG Geotechnical Design Squad, is required before any ground improvement method is implemented.





## **Section 5**

# **SEISMIC DISPLACEMENT DEMAND**

**SCDOT Seismic Design Specifications for Highway Bridges**



## TABLE OF CONTENTS

<b>SECTION 5 - SEISMIC DISPLACEMENT DEMAND .....</b>	<b>5-1</b>
5.1 GENERAL REQUIREMENTS .....	5-1
5.1.1 Analysis Objectives .....	5-1
5.1.2 Exception for Single Span Bridges .....	5-1
5.1.3 Exception for SDC A Bridges.....	5-1
5.1.4 Balanced Stiffness.....	5-1
5.1.5 Balanced Unit Geometry.....	5-1
5.1.6 Adjusting Dynamic Characteristics .....	5-2
5.1.7 Vertical Ground Motion Considerations.....	5-2
5.1.8 Load Combinations.....	5-2
5.2 ANALYTICAL PROCEDURES AND APPLICATIONS.....	5-4
5.2.1 Special Requirements for Curved Bridges.....	5-4
5.2.2 Special Requirements for Geometrically Complex Bridges .....	5-4
5.2.3 Damping Considerations.....	5-6
5.2.4 Displacement Magnification for Short Period Structures .....	5-6
5.3 GLOBAL VS. LOCAL MODELS .....	5-6
5.4 COMBINATION OF ORTHOGONAL SEISMIC DISPLACEMENTS .....	5-7
5.5 MULTIMODE SPECTRUM ANALYSIS MODELING .....	5-7
5.5.1 Mode Shapes and Mass Participation .....	5-7
5.5.2 Superstructure Modeling.....	5-7
5.5.3 Interior Bent Modeling .....	5-7
5.5.4 Compression Model.....	5-7
5.5.5 Tension Model .....	5-7
5.5.6 Bearings .....	5-8
5.5.7 Effective Section Properties.....	5-10
5.6 END BENT SOIL STRUCTURE INTERACTION .....	5-11
5.6.1 End Bent Pile Stiffness .....	5-11
5.6.2 Backwall / Wingwall Modeling.....	5-12
5.7 SUBSTRUCTURE POINT OF FIXITY.....	5-13
5.8 INTERPRETATION / VERIFICATION OF MSA RESULTS.....	5-17
5.9 TIME HISTORY ANALYSIS.....	5-17
5.10 STAND-ALONE ANALYSIS.....	5-17



## SECTION 5 - SEISMIC DISPLACEMENT DEMAND

### 5.1 GENERAL REQUIREMENTS

#### 5.1.1 Analysis Objectives

The objective of seismic analysis is to assess displacement demands and capacities of a bridge and its individual components. Multimode Spectral Analysis (MSA) is the required analytical tool for estimating the displacement demands for SCDOT typical bridges. This analysis procedure is described in Section 5.2.

The requirements of Section 5 shall govern the method of seismic displacement demand analysis of bridges.

#### 5.1.2 Exception for Single Span Bridges

A detailed seismic analysis is not required for single span bridges.

#### 5.1.3 Exception for SDC A Bridges

A detailed seismic analysis is not required for SDC A bridges.

#### 5.1.4 Balanced Stiffness

The ratio of effective stiffness between any two bents within a unit/frame or between any two columns within a bent shall satisfy Equation 5-1. The ratio of effective stiffness between adjacent bents within a unit/frame or between adjacent columns within a bent shall satisfy Equation 5-2. An increase in mass along the length of the unit/frame should be accompanied by a reasonable increase in stiffness. For variable width units, the tributary mass supported by each bent or column shall be included in the stiffness comparison as specified in Equations 5-3 and 5-4, corresponding to Equations 5-1 and 5-2, respectively.

##### Constant Width Units

$$\frac{k_i^e}{k_j^e} \geq 0.5 \quad (5-1)$$

$$\frac{k_i^e}{k_j^e} \geq 0.75 \quad (5-2)$$

##### Variable Width Units

$$\frac{k_i^e m_j}{k_j^e m_i} \geq 0.5 \quad (5-3)$$

$$\frac{k_i^e m_j}{k_j^e m_i} \geq 0.75 \quad (5-4)$$

Where:

- $k_i^e$  The smaller effective bent or column stiffness (k/in)
- $k_j^e$  The larger effective bent or column stiffness (k/in)
- $m_i$  Tributary mass of column or bent (i) (slugs)
- $m_j$  Tributary mass of column or bent (j) (slugs)

The following considerations shall be taken into account when calculating the effective stiffness: framing effects, end conditions, column height, percentage of longitudinal and transverse column steel, column diameter, and foundation flexibility.

Some of the consequences of not meeting the relative stiffness recommendations defined above include:

- Increased damage in the stiffer elements
- An unbalanced distribution of inelastic response throughout the structure
- Increased column torsion generated by rigid body rotation of the superstructure

#### 5.1.5 Balanced Unit Geometry

It is strongly recommended that the fundamental period of vibration ratio of adjacent units in both the longitudinal and transverse direction satisfy Equation 5-5.

$$\frac{T_i}{T_j} \geq 0.7 \quad (5-5)$$

Where:

- $T_i$  Natural period of the less flexible frame or unit (seconds)
- $T_j$  Natural period of the more flexible frame or unit (seconds)

The consequences of not meeting the fundamental period requirements of Equation 5-5 include a greater likelihood of out-of-phase response between adjacent units leading to large relative displacements that increase the probability of longitudinal unseating and pounding between units at the expansion joints. The pounding and relative transverse translation of

adjacent units will transfer the seismic demand from one unit to the next, which can be detrimental to the stand-alone capacity of the unit receiving the additional seismic demand. See Figure 5.1 (for illustration purpose only) for more information.

### 5.1.6 Adjusting Dynamic Characteristics

The following list of techniques should be considered for adjusting or tuning the fundamental period of vibration and/or stiffness to satisfy Equations 5-1 to 5-5.

- Rearrange span layout
- Use of oversized drilled shafts
- Adjust effective column lengths (i.e. lower footings, isolation casing)
- Use of modified end fixities
- Reduce and/or redistribute superstructure mass
- Vary the column cross section and longitudinal reinforcement ratios
- Add or relocate columns
- Modify the hinge/expansion joint layout
- Incorporate isolation bearings or dampers

A careful evaluation of the structure performance is required if project constraints make it impractical to satisfy the stiffness and structure period requirements in Equations 5-1 to 5-5.

### 5.1.7 Vertical Ground Motion Considerations

Vertical ground motion shall be only considered for bridges with SDC D. See Section 8.3 for details.

### 5.1.8 Load Combinations

For most seismic analysis, the dead load of the structure is the only load to be considered. The dead load includes the weight of the structure, future wearing surface, barrier rails, sidewalk, medians, utilities and the weight of any future modification to the structure.

In large metropolitan areas, the inclusion of live load, without impact, in the load combination may be included. The inclusion of live load in the load combination should be discussed with the Department on a case-by-case basis.

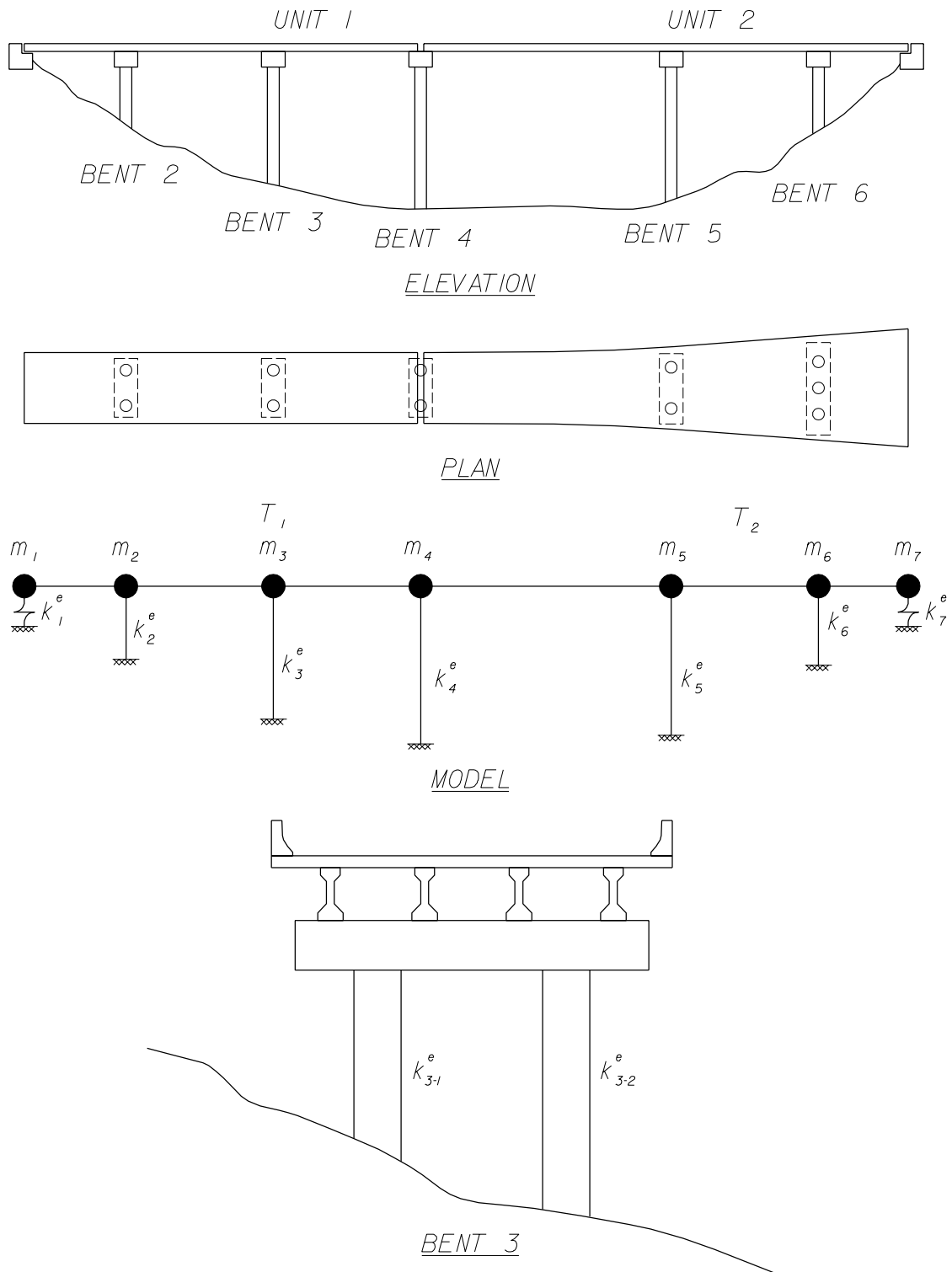
The dead load and live load (when required) shall be applied to the structural model thru the use of the following load combination.

$$EQ = 1.0DL + \gamma LL \quad (5-6)$$

Where:

<i>EQ</i>	Seismic loading
<i>DL</i>	Dead load of structure and all attachments
<i>LL</i>	Live load without impact
$\gamma$	Live load factor typically zero for standard SCDOT bridges (unless otherwise instructed by Department)

The effect of scour on the soil surrounding the substructure of bridges needs to be taken into consideration. Scour is treated as an extreme event in the AASHTO Specifications. Typically, two extreme events are not considered simultaneously. However, since the timing of a seismic event is not predictable, the effect of long term scour should be considered.



**Figure 5.1 Balanced Stiffness**

## 5.2 ANALYTICAL PROCEDURES AND APPLICATIONS

Multimode Spectral Analysis (MSA) is a linear elastic dynamic analysis procedure. MSA shall be used to estimate the displacement demands for all typical SCDOT bridges as defined in Section 1.5. For each structure, a linear elastic multi-modal spectral analysis utilizing the appropriate acceleration response spectrum shall be performed.

The MSA can produce stresses in some elements that exceed their elastic limit, indicating nonlinear behavior. Therefore, forces generated by a MSA could vary considerably from the actual force demands on the structure because of the nonlinear behavior of some elements.

Sources of nonlinear response that are not captured by MSA include the effects of the surrounding soil, yielding of structural components, opening / closing of expansion joints and end bent behavior.

MSA modal results shall be combined using the Complete Quadratic Combination (CQC) method. See Figure 5.3 for the procedure used to obtain seismic displacement demand using a MSA model.

### 5.2.1 Special Requirements for Curved Bridges

A curved bridge may be analyzed as if it were straight provided all of the following requirements are satisfied:

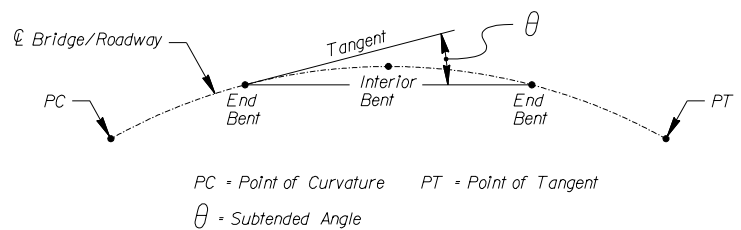
- The bridge is regular as defined in Table 5.1 except for a two-span bridge the maximum to minimum span length ratio must not exceed 2.
- The subtended angle in plan is not greater than 30°, see Figure 5.2.
- The span lengths of the equivalent straight bridge are equal to the arc lengths of the curved bridge (as measured along the centerline of bridge).

If these requirements are not satisfied, then curved bridges shall be analyzed using the actual curved geometry.

**Table 5.1 Regular Bridge Requirements**

Number of Spans	2	3	4	5	6
Maximum Span Length Ratio from Span-to-Span	2	2	2	1.5	1.5
Maximum Bent Stiffness Ratio from Span-to-Span (excluding end bents)	---	4	4	3	2

Note: All ratios expressed in terms of the smaller value

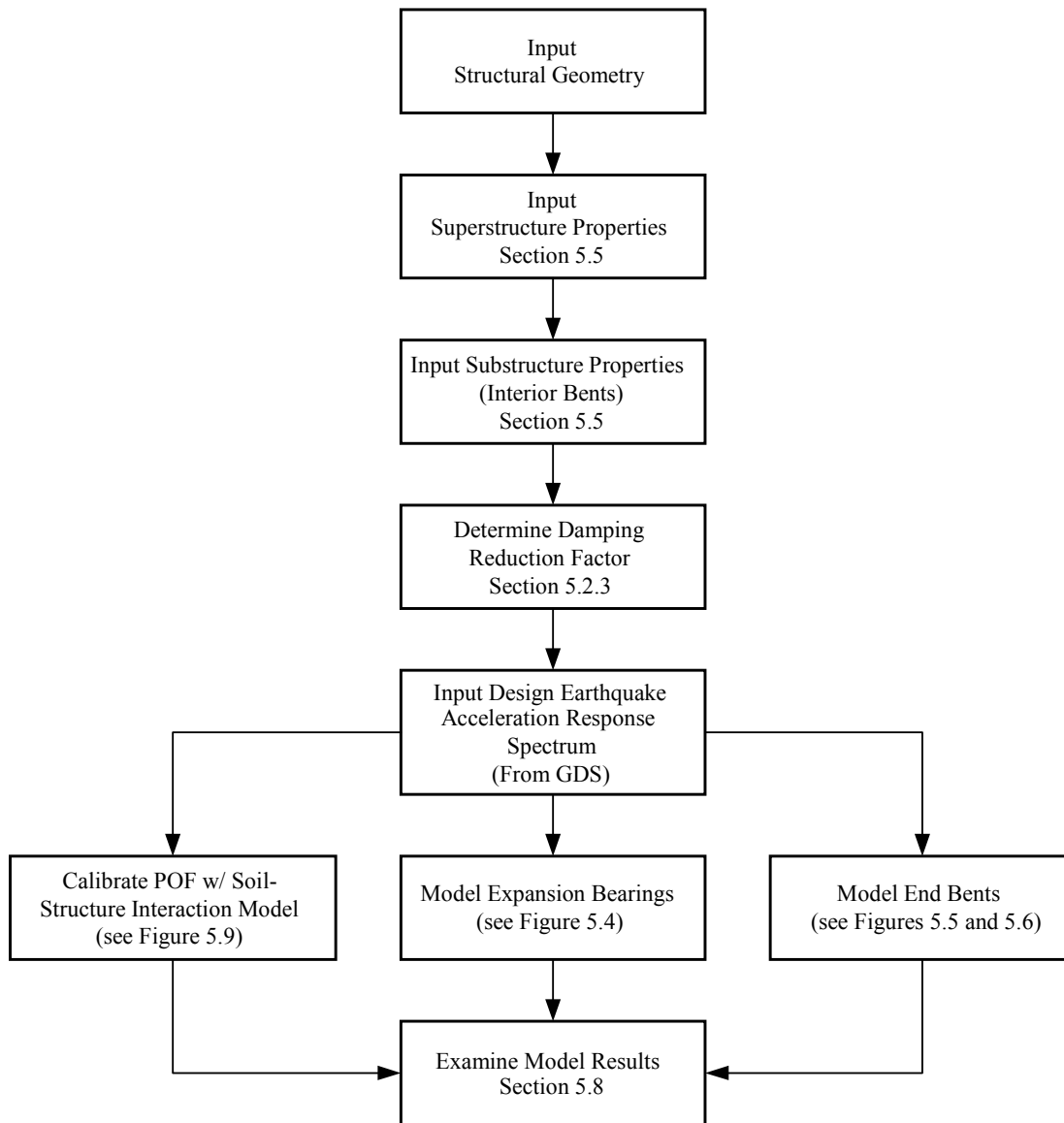


**Figure 5.2 Subtended Angle Definition**

### 5.2.2 Special Requirements for Geometrically Complex Bridges

The Department requires more rigorous methods of analysis for certain important bridges considered to be geometrically complex. Time history methods of analysis are recommended for this purpose, provided care is taken with both the modeling of the structure and the selection of the input time histories of ground motion. Also see Section 5.9.





**Figure 5.3 MSA Modeling Procedure**

### 5.2.3 Damping Considerations

The ADRS Curves for the FEE and SEE are typically based on 5% damping. However, damping ratios on the order of 10% can be used for bridges that are heavily influenced by energy dissipation at the end bents and are expected to respond predominately as a single-degree-of-freedom system. A reduction factor ( $R_D$ ) can be computed using Equation 5-7 and applied to the 5% damped spectrum coefficient used to calculate the displacement demand.

$$R_D = \frac{1.5}{(40c + 1)} + 0.5 \quad (5-7)$$

Where:

- $R_D$  Reduction factor for higher damping ratio (dimensionless)
- $c$  Damping ratio (enter in decimal format maximum of 0.10)

The following criteria should be met before higher damping can be used.

- Total length less than 300 feet (90 m)
- Three spans or less
- End bents designed for sustained soil mobilization
- Normal or slight skew (less than 20 degrees)
- Continuous superstructure without hinges or expansion joints

End diaphragm and integral end bents typically are effective in mobilizing the surrounding soil. However, end bents that respond in a flexible manner may not develop enough sustained structure-soil interaction to reliably provide the higher damping ratio. The displacement demands for bridges with end bents designed to fuse shall be based on a 5% damped spectrum curve unless the end bents are specifically designed for sustained soil mobilization.

### 5.2.4 Displacement Magnification for Short Period Structures

Displacements calculated from elastic analysis shall be multiplied by the factor obtained from Equation 5-8 or 5-9 to obtain the design displacements. This magnification applies when the fundamental period of the structure ( $T$ ) is less than the characteristic ground motion period corresponding to the peak energy input spectrum ( $T^*$ ).

$$T^* = 1.25T_s \quad (5-8)$$

$$R_T = \left(1 - \frac{1}{R}\right) \left(\frac{T^*}{T}\right) + \frac{1}{R} \geq 1 \quad \text{for } \frac{T^*}{T} \geq 1 \quad (5-9a)$$

$$R_T = 1 \quad \text{for } \frac{T^*}{T} < 1 \quad (5-9b)$$

Where:

- $R_T$  Displacement magnification factor to account for short period structures (dimensionless)
- $R$  Force reduction factor obtained by dividing the spectral force by the plastic capacity (dimensionless)
- $T$  Fundamental period of structure (seconds)
- $T^*$  Characteristic ground motion period corresponding to the peak energy input spectrum (seconds)
- $T_s$  Period of acceleration at the beginning of degradation (seconds)

The value of  $R_T$  used shall be taken based on the maximum value of  $R$  expected in the design of the subject bridge. This value is obtained by dividing the spectral force by the plastic capacity of the bridge component where plastic hinging is expected. For plastic capacity calculations, see Section 6.

## 5.3 GLOBAL VS. LOCAL MODELS

For analysis purposes, the entire bridge system is referred to as the "global" model, whereas an individual bent or end bent is referred to as a "local" model. The term "global" describes the overall behavior of the bridge system including the effects of adjacent components, subsystems, or boundary conditions. The term "local" is used to refer to the behavior of an individual component or subsystem, which constitutes its response independent of the effects of adjacent components, subsystems or boundary conditions.

A global model is required to capture the response of the entire bridge system. Bridge systems with irregular geometry, in particular curved bridges and skewed bridges, multiple transverse expansion joints, massive substructure components, and foundations supported by soft soil can exhibit dynamic response characteristics that are not necessarily intuitively obvious and may not be captured in a separate subsystem analysis.

Linear elastic dynamic analysis procedures are generally used for the global response analysis. There are however, some limitations in a linear elastic analysis approach. The nonlinear response of yielding columns, gapped expansion joints,

earthquake restrainers and nonlinear soil properties can only be approximated with a linear elastic approach. A piecewise linear analysis can be used to approximate nonlinear response.

Two global dynamic analyses are required to approximate the nonlinear response of a bridge with expansion joints because it possesses different characteristics in tension versus compression. Thus a tension model and a compression model shall be used.

The structure's geometry will dictate if both a tension model and a compression model are required. See Sections 5.5.4 and 5.5.5 for more information on tension and compression models.

#### **5.4 COMBINATION OF ORTHOGONAL SEISMIC DISPLACEMENTS**

The structure displacement is evaluated in two directions in the MSA model. The first direction is the longitudinal direction, parallel to the centerline of the bridge. The second is the transverse direction, perpendicular to the centerline of the bridge.

A combination of orthogonal seismic displacements is used to account for the directional uncertainty of earthquake motions and the simultaneous occurrences of earthquake forces in two perpendicular horizontal directions. The seismic displacements resulting from analyses in the two perpendicular directions shall be combined to form two load cases as follows:

**LOAD CASE 1:** Seismic displacements on each of the principal axes of a member shall be obtained by adding 100% of the absolute value of the member seismic displacements resulting from the analysis in longitudinal direction to 30% of the absolute value of the corresponding member seismic displacements resulting from the analysis in the transverse direction.

**LOAD CASE 2:** Seismic displacements on each of the principal axes of a member shall be obtained by adding 100% of the absolute value of the member seismic displacements resulting from the analysis in the transverse direction to 30% of the absolute value of the corresponding member seismic displacements resulting from the analysis in the longitudinal direction.

#### **5.5 MULTIMODE SPECTRUM ANALYSIS MODELING**

The bridge should be modeled as a three-dimensional space frame with joints and nodes selected to realistically model the stiffness and inertia effects of

the structure. Each joint or node should have six degrees of freedom, three translational and three rotational. The structural mass should be lumped with a minimum of three translational inertia terms.

The mass should take into account structural elements and other relevant loads including, but not limited to, pier caps, end bents, columns and footings.

##### **5.5.1 Mode Shapes and Mass Participation**

In order to obtain realistic seismic displacements from the MSA, a minimum of 90% of the mass in both the transverse and longitudinal directions shall be mobilized. The higher the number of mode shapes, the more mass participation the model can obtain. The minimum number of mode shapes is three times the number of spans, or 25, whichever is less.

##### **5.5.2 Superstructure Modeling**

The superstructure should, as a minimum, be modeled as a series of space frame members with nodes at the span quarter points in addition to joints at the ends of each span. Discontinuities in the superstructure at the expansion joints and end bents should be included in the model. Care should be taken to distribute properly the lumped mass inertia effects at these locations.

##### **5.5.3 Interior Bent Modeling**

The intermediate columns or piers should also be modeled as space frame members. Columns should be modeled with intermediate nodes at the third points in addition to the joints at the ends of the columns. The model needs to consider the eccentricity of the columns with respect to the superstructure. Foundation conditions at the base of the columns and at the end bents may be modeled using equivalent linear spring coefficients

##### **5.5.4 Compression Model**

In the compression model, the superstructure elements are locked longitudinally to capture structural response modes where the joints close up, mobilizing the end bents when applicable.

##### **5.5.5 Tension Model**

In the tension model, all expansion joints including joints at the end bents are released longitudinally. Bearings elements shall be modeled properly to capture the relative movement between superstructure and substructure.

### 5.5.6 Bearings

Typically two types of bearings are considered in the design of South Carolina bridges in South Carolina: elastomeric and pot bearings. Both types are typically restrained against motion transverse to the centerline of superstructure. Structures can be designed to incorporate one or both bearing types.

The elastomeric bearings can be modeled for two types of stiffness. The first, typically for small displacements, is to model the bearing stiffness based on shear deformation of the bearing. This elastic stiffness is computed using Equation 5-10.

$$k_{FIFI} = \frac{GA_{brg}}{h_{rt}} \quad (5-10)$$

Where:

$k_{FIFI}$	Longitudinal bearing stiffness (k/in)
$G$	Shear modulus of the elastomer (ksi)
$A_{brg}$	Plan area of elastomeric bearing (in <sup>2</sup> )
$h_{rt}$	Total elastomer thickness (in)

For larger displacements, the elastomeric bearing shear capacity will be exceeded and the resistance will come directly from friction between the girder or superstructure and the elastomer. The stiffness for this condition is computed using Equation 5-11.

$$k_{FIFI} = \frac{R_{DL}\mu_f}{\Delta_L} \quad (5-11)$$

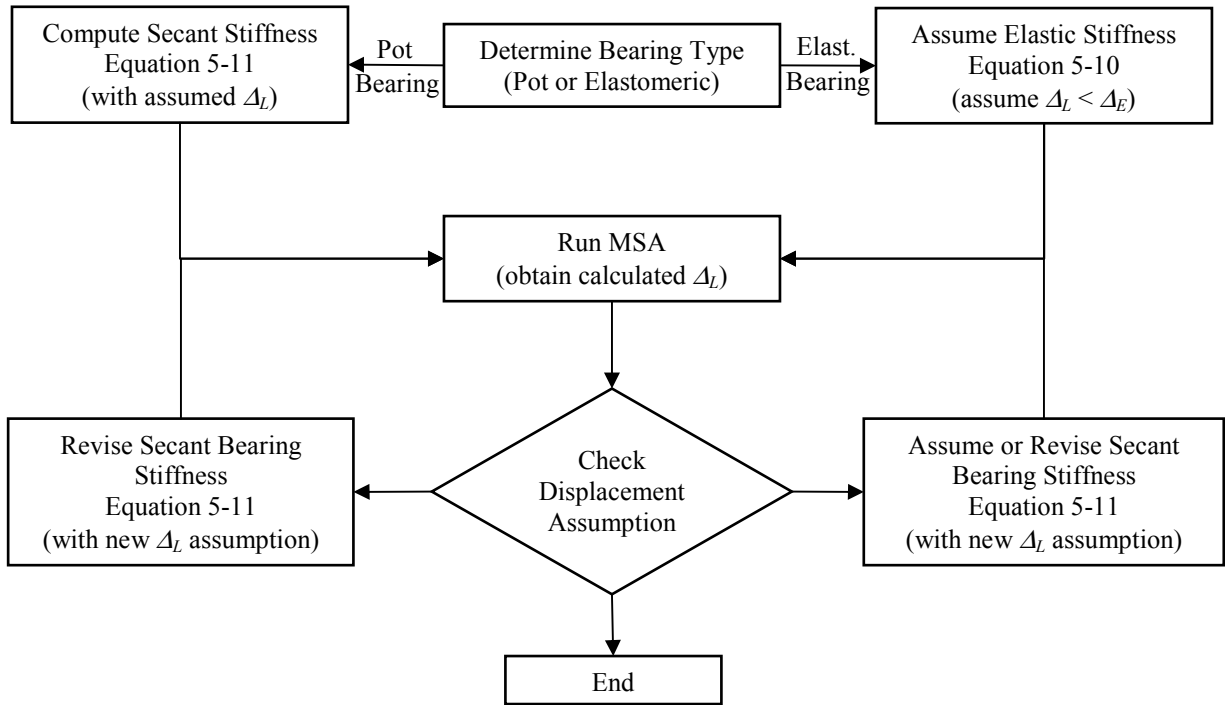
Where:

$k_{FIFI}$	Longitudinal bearing stiffness (k/in)
$R_{DL}$	Dead load girder reaction (k)
$\mu_f$	Coefficient of friction (dimensionless) 0.4 for elastomeric bearings on concrete 0.35 for elastomeric bearings on steel 0.03 for pot bearings
$\Delta_L$	Longitudinal displacement (in)

For pot bearings, resistance is from friction. However, the coefficient of friction for pot bearings is significantly lower than for elastomeric bearings. See Equation 5-11 for computation of longitudinal stiffness for pot bearings.

When attempting to model the expansion bearings in the MSA model, the general procedure is to assume the bearing will remain elastic, and model the elastomeric bearings with Equation 5-10. After the model is analyzed, the bearing displacement is compared to the ultimate bearing elastic shear

deformation ( $\Delta_E$ ). The capacity of the bearing is estimated as half of the total elastomer thickness. If the capacity is exceeded, the bearing is modeled using Equation 5-11. For pot bearings, Equation 5-11 is the only method applicable. See Figure 5.4 for the recommended MSA Bearing modeling procedure.



**Figure 5.4 Bearing Modeling Procedure (Longitudinal Direction)**

In the vertical direction, the elastomeric bearing stiffness is computed using the dead load bearing displacement and the girder dead load reaction, see Equation 5-12.

$$k_{F2F2} = \frac{R_{DL}}{\Delta_v} \quad (5-12)$$

Where:

$k_{F2F2}$	Vertical stiffness (k/in)
$R_{DL}$	Dead load girder reaction (k)
$\Delta_v$	Vertical deflection of bearing from dead load (in)

For pot bearings the vertical stiffness can be assumed fixed for the MSA analysis.

In addition to pot and elastomeric bearings, the use of seismic isolation bearings can be an option to the designers. Use of this bearing type however requires the more detailed time history analysis method. See Section 5.9 for more information.

### 5.5.7 Effective Section Properties

The interior bent substructure will be designed to undergo plastic deformation during a seismic event. In this case, the substructure elements will be subjected to cracking of concrete and yielding of reinforcement. Both of these conditions reduce the sectional properties and capacity of the member. Therefore, the gross section properties of the substructure elements shall not be used in the MSA.

Effective section properties that take into account the plastic damage of the substructure element should be used in the MSA. These can be obtained using a moment – curvature analysis of the section. From this analysis the plastic moment and curvature at the plastic moment can be determined. From these values and the elastic modulus of concrete, the effective or cracked section properties can be computed using Equation 5-13.

$$I_{eff} = \frac{M_p}{\phi_p E_{ce}} \quad (5-13)$$

Where:

$I_{eff}$	Effective flexural moment of inertia (in <sup>4</sup> )
$M_p$	Plastic moment capacity of column, pile or drilled shaft (k-in)
$\phi_p$	Idealized plastic moment curvature (in <sup>-1</sup> )
$E_{ce}$	Elastic modulus of concrete using expected material properties (ksi)

The previously mentioned moment–curvature analysis is discussed in Section 6.

In addition to the effective moment of inertia, the effective torsional moment of inertia needs to be obtained as well. Reduced torsional capacity is taken as 20% of the gross section properties as computed in Equation 5-14.

$$J_{eff} = 0.2J_g \quad (5-14)$$

Where:

$J_{eff}$	Effective torsional moment of inertia (in <sup>4</sup> )
$J_g$	Gross torsional moment of inertia (in <sup>4</sup> )

In the absence of a refined moment-curvature analysis or for preliminary effective stiffness values for substructure elements, the following equations can be used to estimate the effective moment of inertia.

$$I_{eff} = \frac{M_{ne} D'}{2E_{ce} \epsilon_{ye}} \quad (5-15)$$

Where:

$I_{eff}$	Effective flexural moment of inertia (in <sup>4</sup> )
$M_{ne}$	Nominal moment capacity of a reinforced concrete member based on expected material properties (k-in)
$E_{ce}$	Elastic modulus of concrete using expected material properties (ksi)
$\epsilon_{ye}$	Yield strain at expected yield stress of steel reinforcement (in/in)
$D'$	Confined core diameter of a column or effective depth of a rectangular member (in)

Should the flexural strength of the section be unavailable or unknown, the effective moment of inertia can also be approximated using the following equation.

$$I_{eff} = \begin{cases} 0.5I_g & (\text{for columns/piles/shafts}) \\ \frac{I_g}{3} & (\text{for bent caps}) \end{cases} \quad (5-16)$$

Where:

$I_{eff}$	Effective moment of inertia (in <sup>4</sup> )
$I_g$	Gross section moment of inertia (in <sup>4</sup> )

### 5.6 END BENT SOIL STRUCTURE INTERACTION

The various types of soil have an effect on how the structure will behave as well as how it is modeled. Therefore the soil effects must be included in the MSA model.

The soil resistance is separated into two components, the resistance from passive earth pressure, and the resistance of the embedded piles. Assuming the designer models the end bent as springs with the combined stiffness of the embedded piles, backwall and wingwall passive pressure, the total stiffness is computed using Equation 5-17. Each component should be separated into transverse and longitudinal stiffness directions for input into the MSA model.

$$k_{total} = k_{pile} + k_{ww} + \frac{k_{bw}}{2} \tag{5-17}$$

Where:

- $k_{total}$  The total stiffness for the end bent spring in either the transverse or longitudinal direction (k/in)
- $k_{pile}$  The secant or elastic pile stiffness as computed in Section 5.6.1. (k/in)
- $k_{bw}$  The secant or elastic backwall stiffness in the direction of consideration as computed in Section 5.6.2 (k/in)
- $k_{ww}$  The secant or elastic wingwall stiffness in the direction of consideration as computed in Section 5.6.2 (k/in)

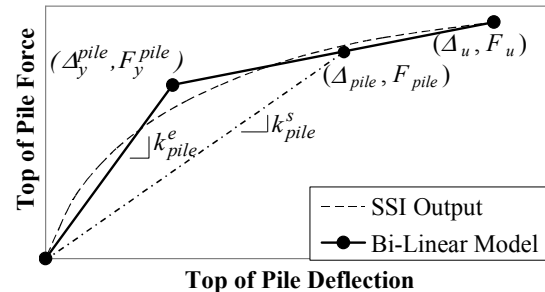
The structural seismic displacement is assumed to engage only one end bent backwall at a time. However most MSA programs do not allow the input of different stiffness values dependent on the direction of motion. For this situation, the stiffness resultant in the longitudinal direction from the passive earth pressure against the backwall is split between the two end bents.

The geotechnical engineer will provide designers with a model of the soil profile for use in determining the soil – structure interaction (SSI). This model will allow designers to estimate the pile stiffness and determine the point of fixity. In addition to the model, the geotechnical engineer will provide the ultimate pressure the soil can sustain.

The flow chart in Figure 5.7 should be used as a guideline for modeling the end bent.

#### 5.6.1 End Bent Pile Stiffness

The elastic pile stiffness for the end bents can be determined through use of the SSI model. A load versus displacement graph is to be generated for the end bent pile in the SSI model (labeled SSI Output), see Figure 5.5.



**Figure 5.5 End Bent Pile Force v/s Displacement**

The elastic pile stiffness, as determined by Equation 5-18, is the recommended starting point for estimating the pile stiffness in the MSA model.

$$k_{pile}^e = \frac{F_y^{pile}}{\Delta_y^{pile}} \tag{5-18}$$

Where:

- $k_{pile}^e$  Elastic pile stiffness from the bi-linear SSI model (k/in)
- $F_y^{pile}$  Estimated yield force of bi-linear model at yield point (k)
- $\Delta_y^{pile}$  Estimated top of pile displacement at yield point of bi-linear model (in)

The idealized yield point is estimated by the designer such as to divide the pile response into an elastic and plastic portion. The goal in selecting the yield point is to balance the area of the actual force displacement graph above and below the bi-linear approximation.

The initial MSA model incorporates the elastic stiffness. The end bent displacement results need to be compared to the idealized yield moment displacement. If the displacement is less than the idealized yield moment displacement, no further changes to the pile stiffness are required. If the displacement exceeds the idealized yield moment displacement, the end bent pile stiffness will need to be adjusted to determine the secant stiffness as computed using Equation 5-19.

$$k_{pile}^s = \frac{F_{pile}}{\Delta_{pile}} \quad (5-19)$$

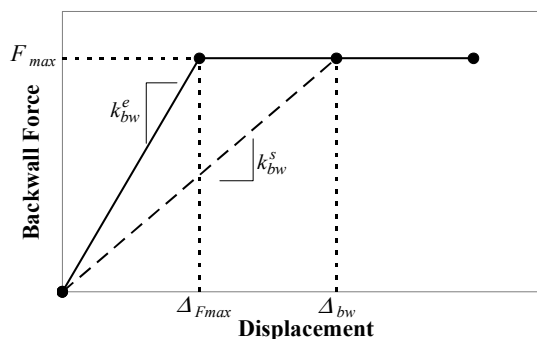
Where:

- $k_{pile}^s$  Secant pile stiffness (k/in)  
 $F_{pile}$  Top of pile force on the bi-linear model corresponding to the estimated displacement (k)  
 $\Delta_{pile}$  Estimated top of pile displacement (in)

The pile stiffness determined using either Equation 5-18 or 5-19 is for lateral movements. The vertical stiffness of the pile is also required to model the structure. The vertical stiffness of a pile can be assumed double that of the lateral stiffness.

### 5.6.2 Backwall / Wingwall Modeling

The geotechnical engineer provides the designer with an ultimate soil pressure for the backwall / wingwall soil. The soil resistance is assumed to be linear until the pressure reaches the ultimate limit. Once the ultimate pressure has been reached, the resistance remains constant for further displacement. Since the stiffness of the end bent is not linear, an equivalent linear stiffness is used in the MSA model for situations when the end bent displacement demand is greater than the yield displacement of the backwall or wingwall soil see Figure 5.6.



**Figure 5.6 Backwall Stiffness Model**

An equivalent linear soil stiffness is valid only if it predicts achievable soil forces. The passive force applied on the backwall can never exceed the passive force capacity of the soil, because the soil will fail before this could happen. If the seismic analysis provides an end bent force that exceeds the soil pressure capacity, then the model is unrealistic, and the spring constants must be reduced before accepting the model results.

This force limit applies to all spring locations, including: soil at backwall and soil at wings.

The starting point for the MSA model backwall / wingwall contribution to the end bent total stiffness is to assume the soil behind the backwall and wingwalls remains elastic. The elastic stiffness is computed using Equation 5-20.

$$k_{bw}^e = \frac{F_{max}}{\Delta_{Fmax}} \quad (5-20)$$

Where:

- $k_{bw}^e$  Elastic backwall or wingwall stiffness (k/in)  
 $F_{max}$  Maximum backwall or wingwall force from passive pressure resistance (k)  
 $\Delta_{Fmax}$  Backwall or wingwall displacement required to fully develop the ultimate backwall passive pressure (in)

The displacement required to fully develop the backwall or wingwall ultimate pressure, depends on the soil properties. Refer to the Geotechnical Design Manual for the displacement required to fully develop the ultimate backwall or wingwall passive pressure. In the absence of site specific data, backwall displacement required to fully develop the ultimate backwall pressure can be estimated using the following equation.

$$\Delta_{Fmax} = 0.02H_{bw} \quad (5-21)$$

Where:

- $\Delta_{Fmax}$  Backwall or wingwall displacement required to fully develop the ultimate backwall passive pressure (in)  
 $H_{bw}$  Height of backwall and cap or wingwall exposed to passive earth pressure (in)

The end bent displacement results need to be compared to the displacement required to fully develop the ultimate backwall passive pressure. If the displacement demand is larger than  $\Delta_{Fmax}$ , Equation 5-22 is used to evaluate the stiffness.

$$k_{bw}^s = \frac{F_{max}}{\Delta_{bw}} \quad (5-22)$$

Where:

- $k_{bw}^s$  Secant stiffness of backwall or wingwall (k/in)  
 $F_{max}$  Maximum backwall or wingwall force from passive pressure resistance (k)



$\Delta_{bw}$  Estimated displacement demand of backwall or wingwall in transverse or longitudinal direction (in)

For the typical SCDOT structure, two wingwalls are used at each end bent. The resistance of the wingwall is due to the pressure of the soil against the inside face of the wall. For wing walls that are of a constant height, there is a small amount of soil present on the outside of the wing wall that can contribute to the resistance. This resistance shall be taken as 1/3 of the adjacent wing. Should the distance between the two wings be greater than 40', the additional resistance from soil on the outside face shall not be included.

### 5.7 SUBSTRUCTURE POINT OF FIXITY

Most MSA methods require the designer to input a point of fixity for the substructure. The Soil Structure Interaction (SSI) model is used iteratively with the MSA model to determine the point of fixity.

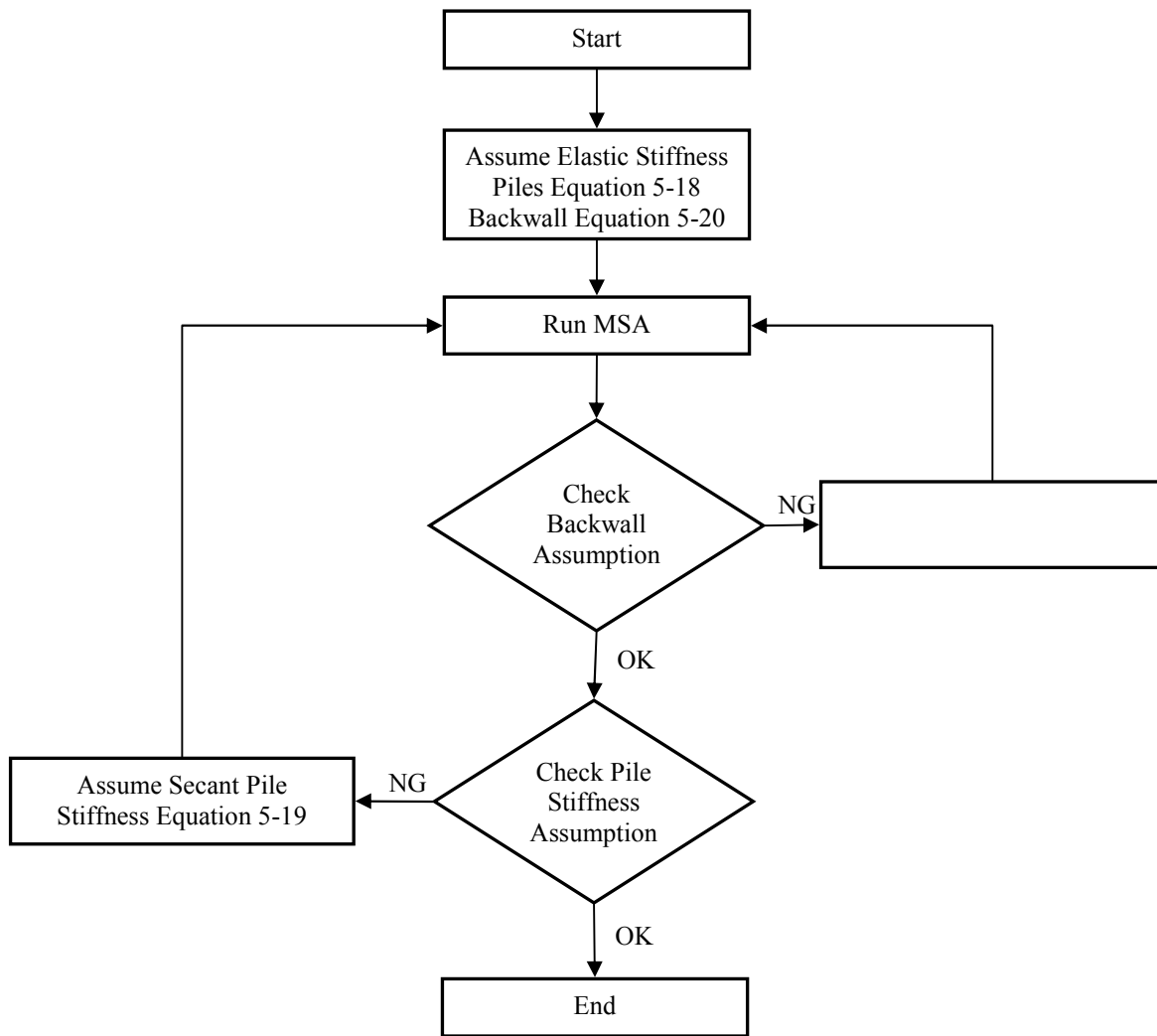
The model of the soil profile for the project, as provided by the geotechnical engineer, is used to estimate the point of fixity location in the MSA model to start the iterative process.

The following locations, which can be determined from the SSI model, may be used as the initial point of fixity in the MSA model; as illustrated in Figure 5.8.

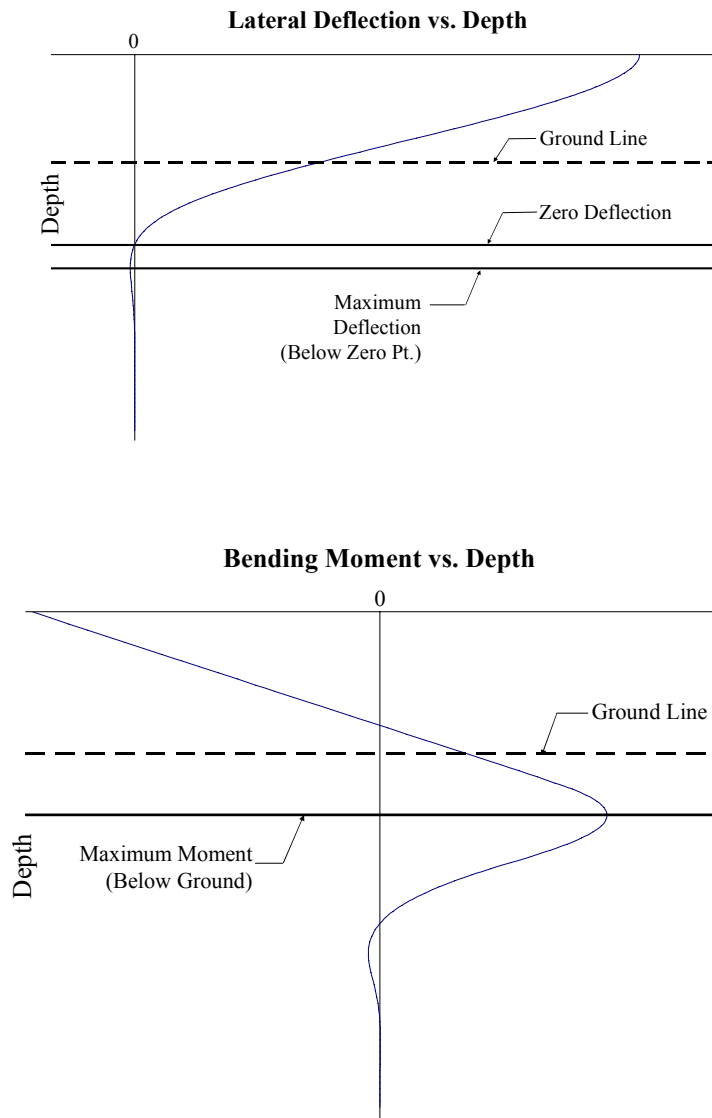
- Point of Maximum Moment
- Point of Zero Deflection
- Point of Maximum Negative Deflection

In order for the MSA model to accurately represent the effects of the soil, the MSA model and the SSI model shall be calibrated. The suggested method is to adjust the point of fixity in the MSA model such that the forces obtained from the MSA model, when input into the SSI model, result in similar displacements. For more information, see Figure 5.9.

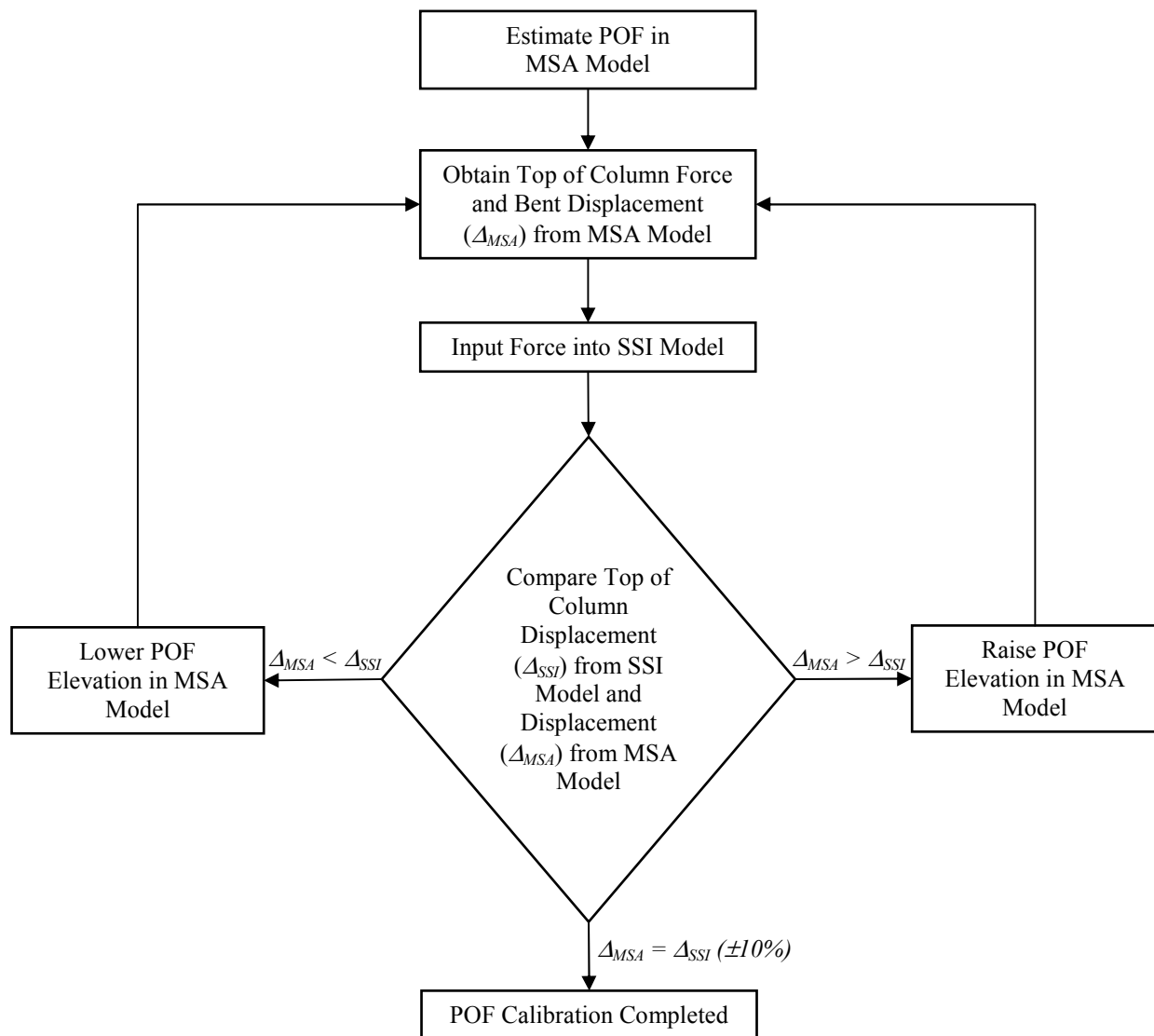
For pile footings, the point of fixity is typically taken to be at the bottom of the column. Therefore no iterations are required for this foundation type.



**Figure 5.7 End Bent MSA Modeling Flowchart**



**Figure 5.8 Possible Point of Fixity Locations**



**Figure 5.9 Iterative Calibration of SSI and MSA Models for Foundation Point of Fixity**

Note: Calibration of End Bent stiffness could affect results of this calibration process (especially in the longitudinal direction). Since only one direction can be calibrated, it is recommended that the transverse direction be selected for calibration. Once the End Bent has been modeled, check the top of column forces to make sure changes to End Bent stiffness do not significantly change the top of column forces.

## 5.8 INTERPRETATION / VERIFICATION OF MSA RESULTS

The MSA results shall be verified to ensure accuracy and correctness. The designer should use the following procedures for model verification.

- Using graphics, check the orientation of all nodes, members, supports, joint and member releases. Make sure that all structural components and connections correctly model the actual structure.
- Check dead load reactions with hand calculations. The difference should be less than 5 percent.
- Calculate fundamental and subsequent modes by hand and compare results with MSA results.
- Check the mode shapes and verify that structure movements are reasonable.
- Check the distribution of lateral forces. Are they consistent with the column stiffnesses? Do small changes in stiffness of certain columns give predictable results?

The objective of the MSA is to obtain the displacement demand of the structure. From the calibrated model, the displacement of each interior bent and end bent should be obtained for both the longitudinal and transverse direction.

## 5.9 TIME HISTORY ANALYSIS

The non-linear time history analysis method is not normally required for "typical" SCDOT bridges. The time histories of input acceleration used to describe earthquake load will be selected in consultation with SCDOT and will be provided by the PCS/GDS, in consultation with the Regional Production Group GDS, for those non typical structures, as determined by the SCDOT, requiring time history analysis.

### 5.10 STAND-ALONE ANALYSIS

When the SDC has been determined to be SDC D, stand-alone analysis shall be performed in both the transverse and longitudinal directions on each individual unit separately.

#### (a) Transverse Stand-Alone Analysis

Transverse stand-alone unit models shall assume lumped mass at the columns. The transverse analysis of end units shall include a realistic estimate of the end bent stiffness consistent with the expected end bent performance. The transverse displacement demand at each bent in a unit shall include the effects

of rigid body rotation around the center of rigidity for the unit.

#### (b) Longitudinal Stand-Alone Analysis

Longitudinal stand-alone unit models typically ignore the free standing end bent stiffness for structures with more than two units, an overall length greater than 300 feet or significant horizontal curvature, since the controlling displacement occurs when the unit is moving away from the end bent. A realistic estimate of the end bent stiffness may be incorporated into the stand-alone analysis for single unit tangent bridges and two unit tangent bridges less than 300 feet in length. However, stiffness of integral/semi-integral end bents shall be included in the longitudinal stand-alone analysis for the end units.



## **Section 6**

# **SEISMIC DISPLACEMENT CAPACITY**

**SCDOT Seismic Design Specifications for Highway Bridges**





## TABLE OF CONTENTS

<b>SECTION 6 - SEISMIC DISPLACEMENT CAPACITY .....</b>	<b>6-1</b>
6.1 ANALYSIS OBJECTIVES .....	6-1
6.2 DEFINITION OF PLASTIC HINGES .....	6-1
6.3 LOCATIONS OF PLASTIC HINGES .....	6-1
6.4 PLASTIC HINGE ACCESSIBILITY .....	6-2
6.5 DISPLACEMENT CAPACITY OF DUCTILE CONCRETE MEMBERS .....	6-2
6.5.1 Ductile Member Definition.....	6-2
6.5.2 Member Displacement Capacity.....	6-5
6.5.3 Displacement Capacity for SDC B Bridges.....	6-10
6.5.4 Yield Displacement for SDC B Bridges.....	6-10
6.6 MATERIAL PROPERTIES FOR CONCRETE COMPONENTS.....	6-10
6.6.1 Expected Material Properties.....	6-10
6.6.2 Nonlinear Reinforcement Steel Model for Ductile Reinforced Concrete Members.....	6-10
6.6.3 Nonlinear Prestressing Strand Model .....	6-11
6.6.4 Unconfined Concrete Model.....	6-12
6.6.5 Confined Concrete Model.....	6-12
6.6.6 Structural Steel Material Properties .....	6-14
6.6.7 Normal Weight Portland Cement Concrete Properties.....	6-14
6.6.8 Sand-Lightweight Concrete Properties .....	6-14
6.6.9 Other Material Properties.....	6-14
6.7 PLASTIC MOMENT CAPACITY FOR DUCTILE CONCRETE MEMBERS .....	6-14
6.7.1 Analytical Modeling of Composite Section.....	6-14
6.7.2 Interpretation of Analysis Results.....	6-14
6.7.3 Reinforced Concrete Moment Curvature ( $M-\phi$ ) Analysis .....	6-15
6.7.4 Prestressed Concrete Moment Curvature ( $M-\phi$ ) Analysis .....	6-15
6.7.5 Shear and Moment Capacity .....	6-15
6.8 PUSH-OVER ANALYSIS .....	6-17
6.8.1 Load-Displacement (P-Y) Curves.....	6-17
6.8.2 Moment Rotation Hinges.....	6-17
6.9 REQUIREMENTS FOR CAPACITY-PROTECTED COMPONENTS.....	6-18



## SECTION 6 - SEISMIC DISPLACEMENT CAPACITY

### 6.1 ANALYSIS OBJECTIVES

The seismic displacement capacity and yield displacement of a structure needs to be determined for SDC B to SDC D bridges. They can be estimated for SDC B bridges using the equations presented in Sections 6.5.3 and 6.5.4. A more accurate method of obtaining the displacement capacity is through pushover analysis. This method is required for SDC C and SDC D bridges.

Pushover analysis takes into account the non-linearity of the materials, structure and surrounding soil. Substructure displacement can be broken down into elastic displacement and plastic displacement. The transition between elastic and plastic displacement is the yield displacement (see Figure 1.1). Since the superstructure is designed to remain elastic, the substructure elements are the only components modeled.

### 6.2 DEFINITION OF PLASTIC HINGES

The analytical plastic hinge length is the equivalent length of column over which the plastic curvature is assumed constant for estimating the plastic rotation. The plastic rotation is then used to calculate the plastic displacement of an equivalent member from the point of maximum moment to the point of contraflexure.

The plastic hinge lengths are calculated for the following four conditions:

- (a) *Concrete Columns Framing into a Footing, Bent Cap or Oversized Shaft*

$$L_p = 0.08L' + 0.15f_{ye}d_{bl} \geq 0.3f_{ye}d_{bl} \quad (6-1)$$

- (b) *Prestressed Concrete Piles Framing into a Footing or Bent Cap*

$$L_p = 0.08L' \geq D^* \quad (6-2)$$

- (c) *Prismatic Concrete Columns or Drilled Shafts*

$$L_p = D^* + 0.08H' \quad (6-3)$$

- (d) *Steel Columns / Piles*

$$L_p = 0.125H \geq 18'' \quad (6-4)$$

Where:

$L_p$	Analytical plastic hinge length (in)
$L'$	Length of column from point of contraflexure to cap, footing or oversized shaft (in)
$f_{ye}$	Expected yield strength of reinforcement steel (ksi)
$d_{bl}$	Longitudinal reinforcement nominal bar diameter (in)
$D^*$	Diameter or cross section dimension in direction of bending (in)
$H$	Height of the substructure above ground or river/stream bed to the top of bent cap (in)
$H'$	Length of pile/column from point of maximum moment below ground to point of contraflexure above ground (in)

The plastic hinge region,  $L_{pr}$ , which is the portion of the column, pile, pier or shaft that requires enhanced detailing of lateral confinement, is defined by the larger of:

- 1.5 times the cross sectional dimension in the direction of bending
- The region of column where the moment exceeds 75% of the effective yield moment
- The analytical plastic hinge length ( $L_p$ ) as computed using Equations 6-1 to 6-4.

### 6.3 LOCATIONS OF PLASTIC HINGES

The plastic hinge occurs in different locations depending on the direction of substructure movement. For conventional (non-integral) bents or piers moving in the transverse direction, the plastic hinge is expected to form in two locations. For conventional (non-integral) bents or piers moving in the longitudinal direction, the plastic hinge is expected to form in one location, see Figure 6.1.

For movement in the transverse (parallel to the centerline of the bent cap) direction, the cap to pile / column connection is typically assumed to be fixed against rotation. Therefore the moment will develop at the top of the pile or column as well as a location at or below ground level, see Figure 6.1.

For movement in the longitudinal (perpendicular to the centerline of the bent cap) direction, typical elastomeric bearings and pot bearings are assumed not to transfer any moment. Therefore the moment at top of column is relatively small and the plastic hinge is expected to form in a location at or below ground level.

Should an integral bent cap be required, the connection between the superstructure and substructure will prevent rotation. Thus the plastic hinge could form at the top of column in addition to the location at or below ground level.

Table 6.1 summarizes the allowable location of the plastic hinge (above or below ground) for drilled shafts and prestressed concrete piles. See Section 3.1 for more information on the preferred plastic hinge locations. The designer shall take measures to ensure that a bridge has satisfactory performance under the design earthquake (SEE).

**Table 6.1 Plastic Hinge Locations**

		Operational Classification		
		I	II	III
Interior Bents	Above Ground	Yes	Yes	Yes
	Below Ground	No	Yes <sup>1</sup>	Yes <sup>1</sup>
End Bent	Above Ground	NA <sup>2</sup>	NA <sup>2</sup>	NA <sup>2</sup>
	Below Ground	No	Yes <sup>1</sup>	Yes <sup>1</sup>
Pile Footing	Above Ground	NA <sup>2</sup>	NA <sup>2</sup>	NA <sup>2</sup>
	Below Ground	No	No	No

1. Plastic hinge allowed only with permission from SCDOT’s Regional Production Group (RPG) Structural Engineer, in consultation with the Structural Design Support Engineer.
2. Piles/shafts for end bent and pile footing are typically below ground. Hence, the requirements for above ground plastic hinges are not applicable.

**6.4 PLASTIC HINGE ACCESSIBILITY**

In some instances, such as for Operational Classification "I" bridges, the structural geometry should be detailed such that any plastic hinge forms above ground. A hinge that forms in this location should be easily identified and accessible for repair without significant excavation.

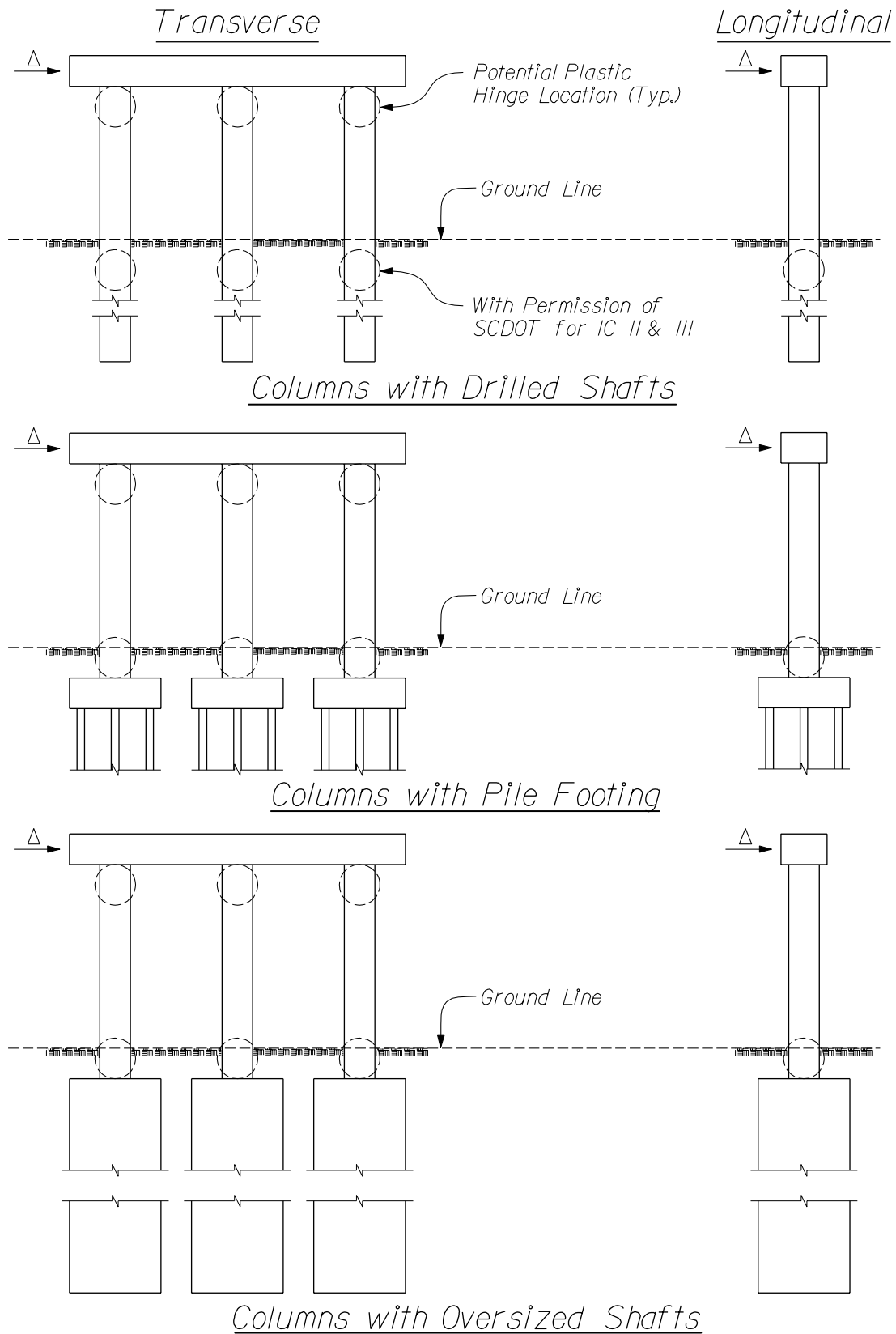
There are two foundation arrangements that lend themselves to above ground plastic hinges. The first is a column with pile footing as shown in Figure 6.1. The second is a column with oversized drilled shaft as shown in Figure 6.1.

The key to forcing the plastic hinge above ground with the oversized drilled shaft is placing the transverse reinforcement in the shaft at a larger diameter than the column framing into the shaft. Providing a larger diameter of transverse reinforcement increases the area of confined concrete in the region, see Figure 6.2.

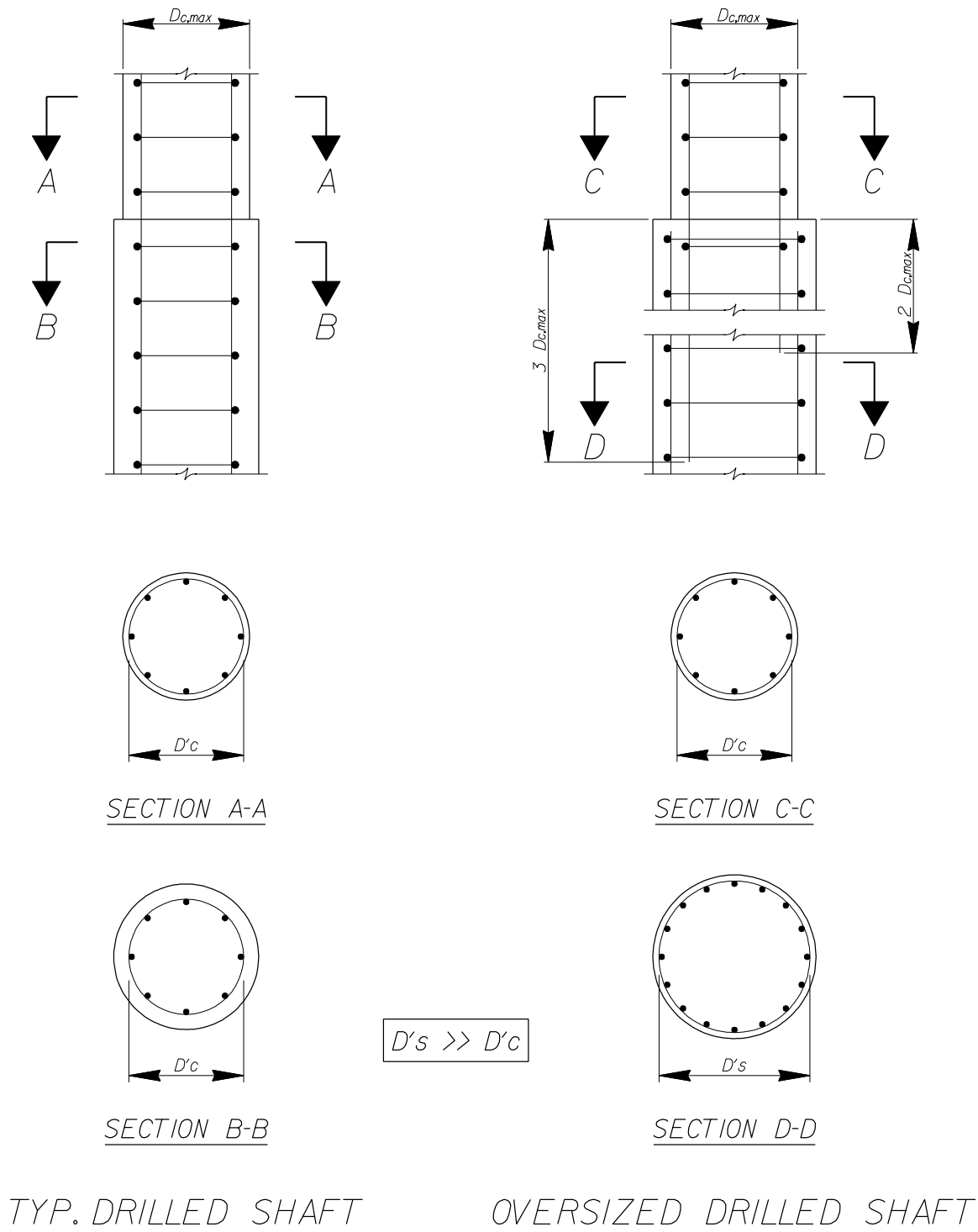
**6.5 DISPLACEMENT CAPACITY OF DUCTILE CONCRETE MEMBERS**

**6.5.1 Ductile Member Definition**

A ductile member is defined as any member designed to deform inelastically for several cycles without significant degradation of strength or stiffness under the demands generated by the SEE event.



**Figure 6.1 Potential Plastic Hinge Locations**



**Figure 6.2 Typical and Oversized Drilled Shafts**

### 6.5.2 Member Displacement Capacity

The displacement capacity of a member is based on its rotation capacity, which in turn is based on its curvature capacity. The curvature capacity shall be determined by  $M-\phi$  analysis, see Section 6.7. The displacement capacity,  $\Delta_c$ , of any column may be idealized as one or two cantilever segments presented in Equations 6-5 to 6-8 and 6-9 to 6-18, respectively. See Figures 6.3 to 6.6 for details. Figures 6.5 and 6.6 are for typical drilled shaft foundation. If oversized drilled shaft or steel construction casing is used, the designer shall consider the effect of different moment curvature in the oversized drilled shaft or the shaft with steel casing. Refined analysis shall be performed for this type of conditions.

One cantilever segment

$$\Delta_c = \Delta_y + \Delta_p \quad (6-5)$$

$$\Delta_y = \frac{L^2}{3} \phi_y \quad (6-6)$$

$$\phi_p = \phi_u - \phi_y \quad (6-7)$$

$$\Delta_p = \theta_p \left( L - \frac{L_p}{2} \right) \quad (6-8)$$

Two cantilever segments

$$\Delta_{c1} = \Delta_{y1} + \Delta_{p1} \quad (6-9)$$

$$\Delta_{c2} = \Delta_{y2} + \Delta_{p2} \quad (6-10)$$

$$\theta_{p1} = L_{p1} \phi_{p1} \quad (6-11)$$

$$\theta_{p2} = L_{p2} \phi_{p2} \quad (6-12)$$

$$\phi_{p1} = \phi_{u1} - \phi_{y1} \quad (6-13)$$

$$\phi_{p2} = \phi_{u2} - \phi_{y2} \quad (6-14)$$

$$\Delta_{p1} = \theta_{p1} \left( L_1 - \frac{L_{p1}}{2} \right) \quad (6-15)$$

$$\Delta_{p2} = \theta_{p2} \left( L_2 - \frac{L_{p2}}{2} \right) \quad (6-16)$$

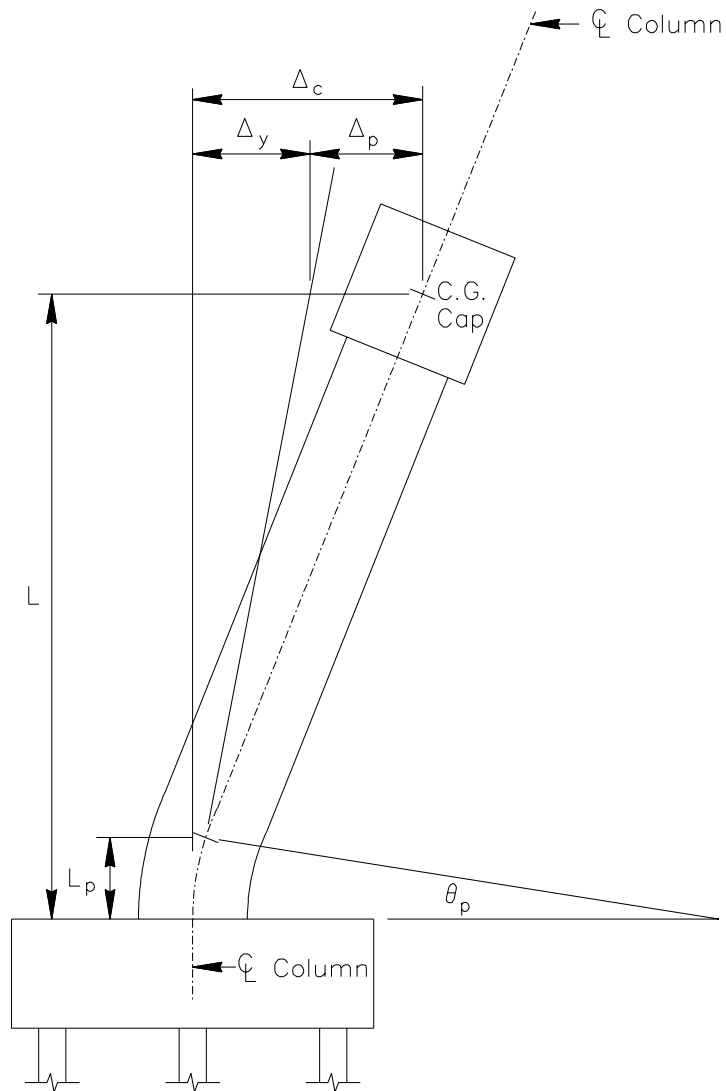
$$\Delta_{y1} = \frac{L_1^2}{3} \phi_{y1} \quad (6-17)$$

$$\Delta_{y2} = \frac{L_2^2}{3} \phi_{y2} \quad (6-18)$$

Where:

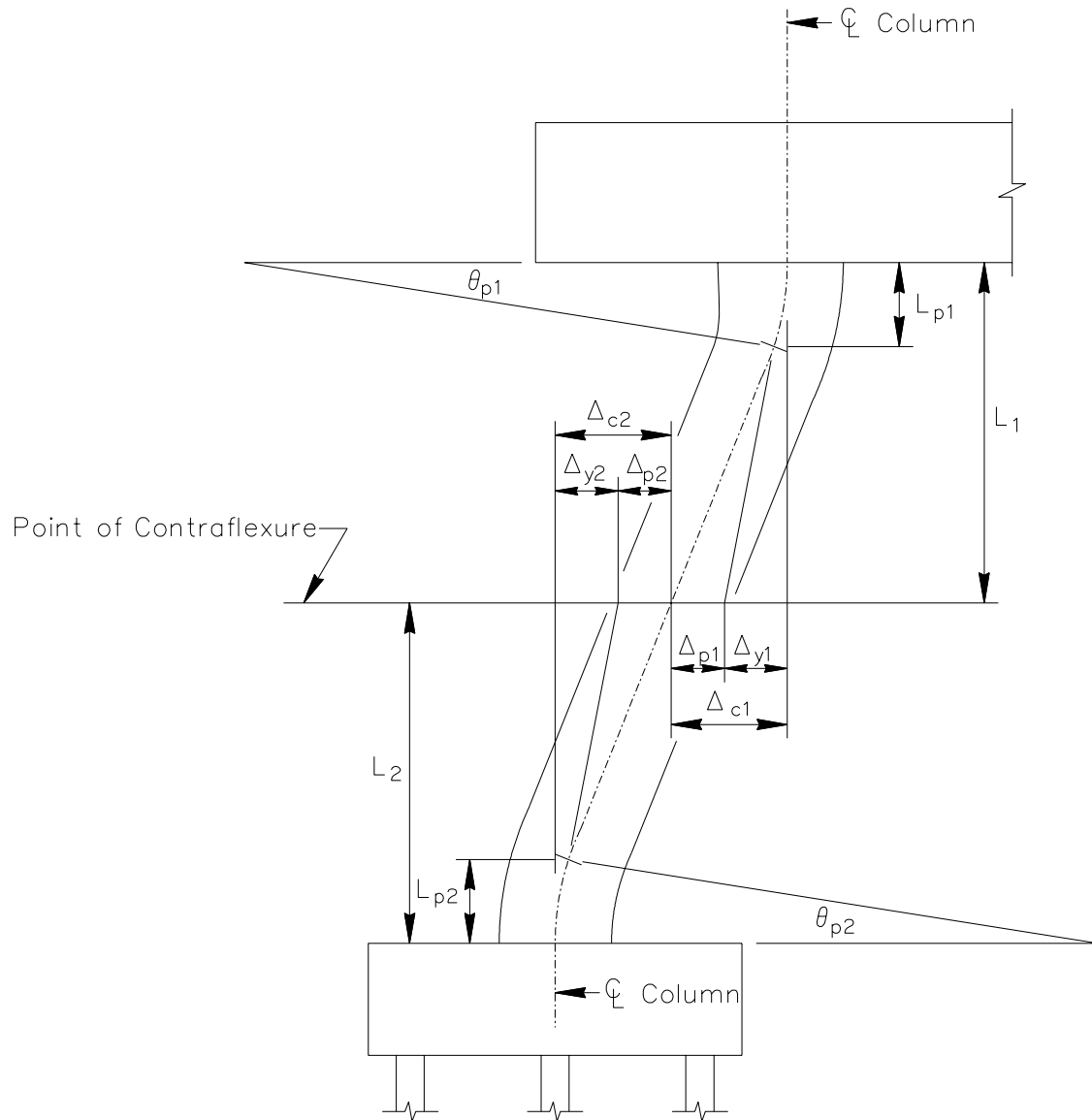
- $L$  Distance from the point of maximum moment to the point of contraflexure (in)
- $L_1$  Length of column from top of column to point of contraflexure (in)
- $L_2$  Length of column from the point of contraflexure to the bottom of column (in)
- $L_p$  Analytical plastic hinge length (in)
- $L_{p1}$  Analytical plastic hinge length of the first cantilever segment (in)

- $L_{p2}$  Analytical plastic hinge length of the second cantilever segment (in)
- $\Delta_c$  Displacement capacity (in)
- $\Delta_{c1}$  Displacement capacity of first cantilever segment (in)
- $\Delta_{c2}$  Displacement capacity of second cantilever segment (in)
- $\Delta_p$  Plastic displacement (in)
- $\Delta_{p1}$  Plastic displacement capacity of first cantilever segment (in)
- $\Delta_{p2}$  Plastic displacement capacity of second cantilever segment (in)
- $\Delta_y$  Yield displacement (in)
- $\Delta_{y1}$  Yield displacement of the first cantilever segment (in)
- $\Delta_{y2}$  Yield displacement of the second cantilever segment (in)
- $\phi_y$  Yield curvature (in<sup>-1</sup>)
- $\phi_{y1}$  Yield curvature of the first cantilever segment (in<sup>-1</sup>)
- $\phi_{y2}$  Yield curvature of the second cantilever segment (in<sup>-1</sup>)
- $\phi_p$  Idealized plastic moment curvature (assumed constant over  $L_p$ ) (in<sup>-1</sup>)
- $\phi_{p1}$  Idealized plastic moment curvature of the first cantilever segment (assumed constant over  $L_{p1}$ ) (in<sup>-1</sup>)
- $\phi_{p2}$  Idealized plastic moment curvature of the second cantilever segment (assumed constant over  $L_{p2}$ ) (in<sup>-1</sup>)
- $\phi_u$  Curvature at failure, defined as the confined concrete strain reaching  $\epsilon_{ccu}$  or the confinement reinforcement steel reaching the ultimate strain  $\epsilon_{su}$  (in<sup>-1</sup>)
- $\phi_{u1}$  Curvature at failure of the first cantilever segment, defined as the confined concrete strain reaching  $\epsilon_{ccu}$  or the confinement reinforcement steel reaching the ultimate strain  $\epsilon_{su}$  (in<sup>-1</sup>)
- $\phi_{u2}$  Curvature at failure of the second cantilever segment, defined as the confined concrete strain reaching  $\epsilon_{ccu}$  or the confinement reinforcement steel reaching the ultimate strain  $\epsilon_{su}$  (in<sup>-1</sup>)
- $\theta_p$  Plastic rotation (radians) ( $\theta_p = L_p \phi_p$ )
- $\theta_{p1}$  Plastic rotation of the first cantilever segment (radians)
- $\theta_{p2}$  Plastic rotation of the second cantilever segment (radians)

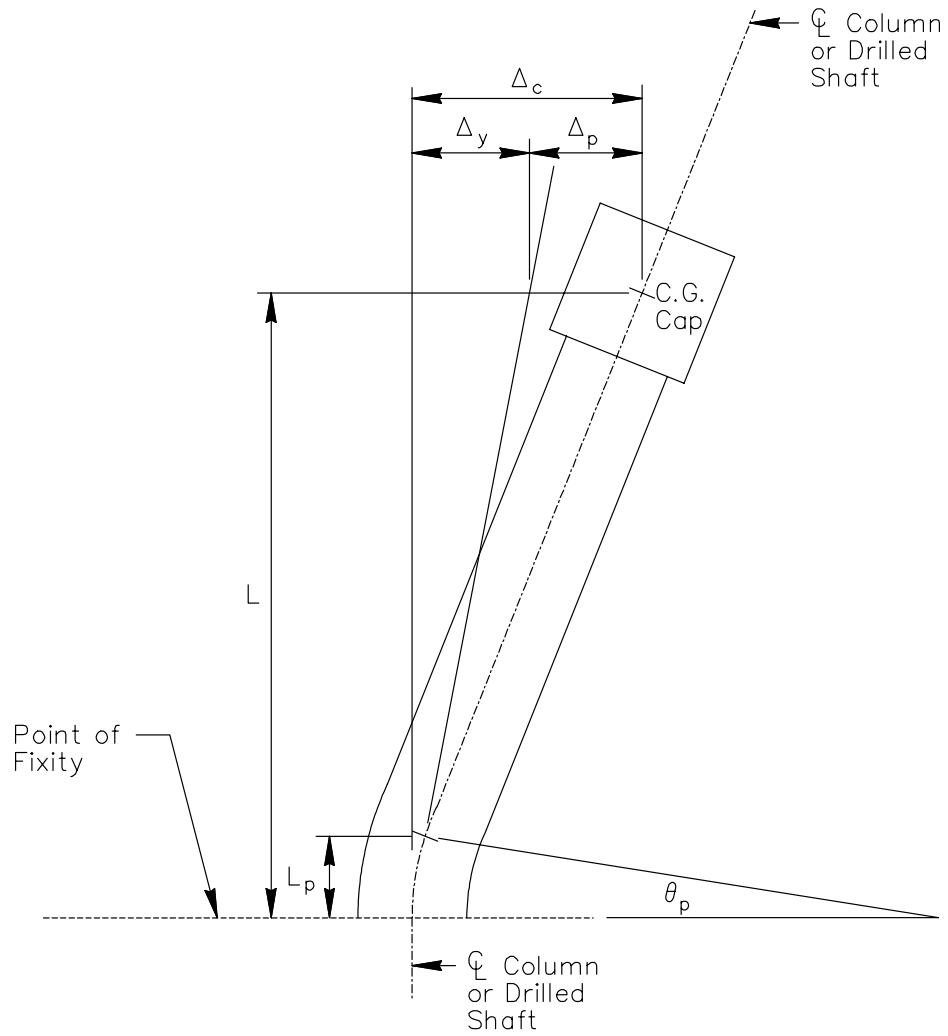


**Figure 6.3 Displacement Capacity for One Cantilever Segment (Longitudinal or Free Head)**

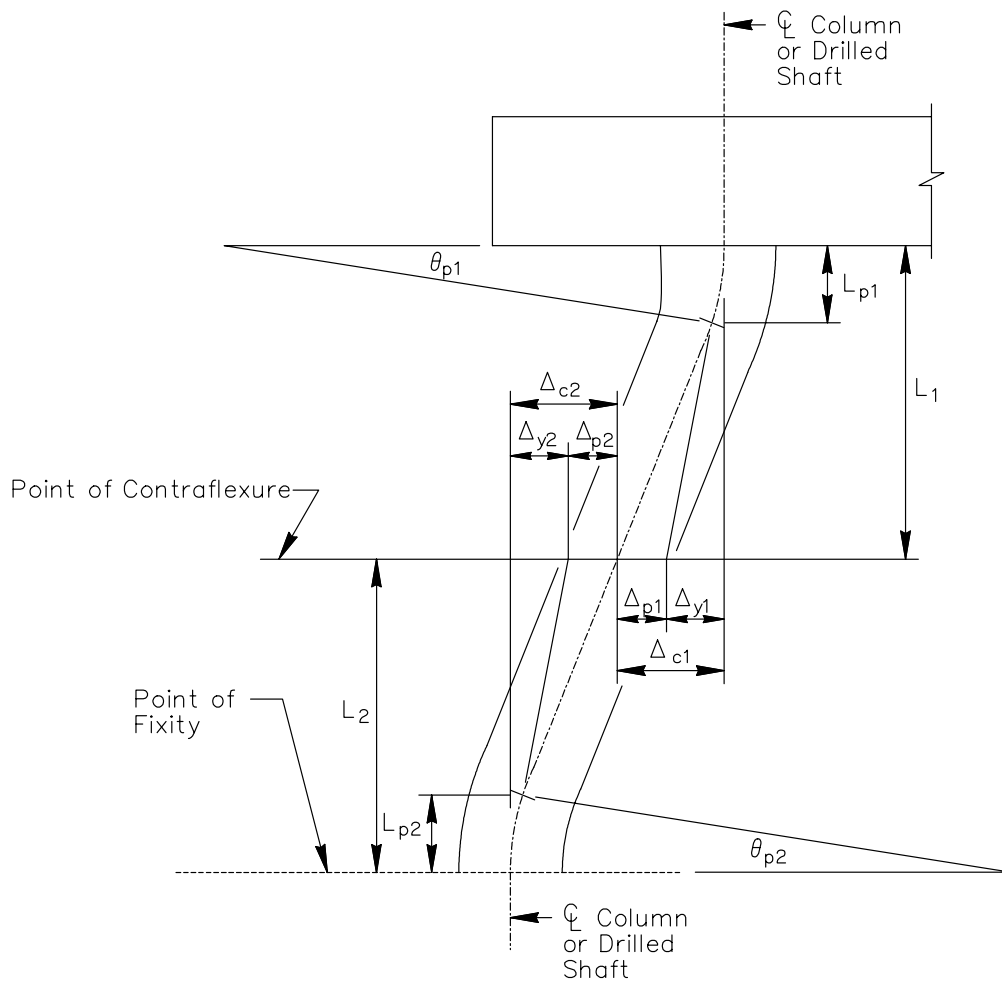




**Figure 6.4 Displacement Capacity for Two Cantilever Segments (Transverse or Fixed Head)**



**Figure 6.5 Displacement Capacity for Column/Drilled Shaft (Longitudinal)**



**Figure 6.6 Displacement Capacity for Column/Drilled Shaft (Transverse)**

### 6.5.3 Simplified Displacement Capacity for SDC B Bridges

For SDC B bridges, the displacement capacity of each bent may be estimated by either using Equation 6-19 or the Equations given in Section 6.5.2:

$$\Delta_c = 0.12h(-1.27 \ln(X) - 0.32) \geq 0.12h \quad (6-19)$$

$$X = A \frac{D}{h} \quad (6-20)$$

Where:

- $\Delta_c$  Displacement capacity (in)
- $A$  Fixity factor for the column (1 for fixed-free and 2 for fixed-fixed end conditions)
- $D$  Column diameter or pile width in direction of bending (ft)
- $h$  Clear height of column (ft)

### 6.5.4 Simplified Yield Displacement for SDC B Bridges

For SDC B, the yield displacement for each bent may be estimated using either Equation 6-21 or the Equations presented in Section 6.5.2.

$$\Delta_y = \frac{M_p L_y^2}{\Psi EI} \quad (6-21)$$

Where:

- $\Delta_y$  Yield displacement (in)
- $M_p$  Plastic moment capacity of column, pile or drilled shaft (k-in)
- $L_y$  Distance from top of column, pile or drilled shaft to the point of fixity used in the MSA model or the top of footing for bents with pile footings (in)
- $\Psi$  Fixity factor for the column or pile, 6 for fixed-fixed and 3 for fixed-free end conditions
- $E$  Modulus of elasticity of column, pile or drilled shaft using expected material properties (ksi)
- $I$  Moment of inertia of column for pile footing or oversized shaft foundations, or drilled shaft for drilled shaft foundations (in<sup>4</sup>)

## 6.6 MATERIAL PROPERTIES FOR CONCRETE COMPONENTS

### 6.6.1 Expected Material Properties

Expected material properties shall be used to determine section properties for the purpose of

establishing displacement capacity of the bridge system and the ductility capacities of the various components.

Typically the expected material properties are higher than those specified in the design. The concrete and reinforcement steel properties used to compute the displacement capacity are those with the most uncertainty. Concrete has a specified 28-day compressive strength used in design, but the concrete provided typically has a higher strength in order to consistently meet acceptance criteria. Concrete also continues to gain strength with time. Therefore an older structure could have a much higher concrete compressive strength than specified in the design. Reinforcement steel is produced to certain standards. These standards specify a minimum and maximum yield stress for the material. The minimum is typically used to check design stresses. However, a higher strength rebar could be used, and still be within the specified tolerances.

Structural steel and prestressing strands have historically been shown not to vary significantly in their material properties from what is specified on the plans. Therefore these material properties are used at their design values.

The following non-linear stress-strain models are provided as a basis for modeling the materials. There may be other, equally accurate models for the materials available. The designer may use other means of modeling the material so long as the non-linearity of the material is captured.

### 6.6.2 Nonlinear Reinforcement Steel Model for Ductile Reinforced Concrete Members

SCDOT requires A706 reinforcement steel to be used in all SCDOT bridge structures. Reinforcement steel shall be modeled with a stress-strain relationship curve (see Figure 6.7) that exhibits an initial elastic portion, a yield plateau, and a strain hardening range in which the stress increases with strain. Within the elastic region the modulus of elasticity,  $E_s$ , shall be 29,000 ksi. ASTM A706 reinforcement steel has the following expected properties:

$$f_{ye} = 1.1f_y \quad (6-22)$$

Where:

- $f_{ye}$  Expected yield strength of reinforcement steel (ksi)
- $f_y$  Specified minimum yield strength of reinforcement steel (ksi)

$$f_{ue} = 1.4f_{ye} \quad (6-23)$$

Where:

$f_{ue}$  Expected ultimate tensile strength of reinforcement steel (ksi)

$f_{ye}$  Expected yield strength of reinforcement steel (ksi)

The reduced ultimate tensile strain of steel reinforcement,  $\epsilon_{su}^R$ , shall be:

$$\epsilon_{su}^R = 0.09 \text{ in/in for \#10 bars or smaller}$$

$$\epsilon_{su}^R = 0.06 \text{ in/in for \#11 bars or larger}$$

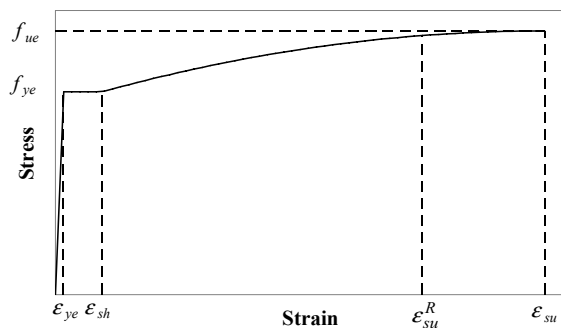
The ultimate tensile strain of steel reinforcement,  $\epsilon_{su}$ , shall be:

$$\epsilon_{su} = 0.12 \text{ in/in for \#10 bars or smaller}$$

$$\epsilon_{su} = 0.09 \text{ in/in for \#11 bars or larger}$$

The onset of strain hardening of steel reinforcement,  $\epsilon_{sh}$ , shall be:

$$\epsilon_{sh} = \begin{cases} 0.0150 \text{ in/in \#8 bars and smaller} \\ 0.0125 \text{ in/in \#9 bars} \\ 0.0115 \text{ in/in \#10 and \#11 bars} \\ 0.0075 \text{ in/in \#14 bars} \\ 0.0050 \text{ in/in \#18 bars} \end{cases}$$



**Figure 6.7 Reinforcement Steel Stress-Strain Model**

The stress-strain diagram for the nonlinear reinforcement steel can be modeled with the following equations.

$$\epsilon_{ye} = \frac{f_{ye}}{E_s} \quad (6-24)$$

$$\text{If } \epsilon_s < \epsilon_{ye} \text{ then } f_s = E_s \epsilon_s \quad (6-25)$$

$$\text{If } \epsilon_{ye} \leq \epsilon_s < \epsilon_{sh} \text{ then } f_s = f_{ye} \quad (6-26)$$

$$\text{If } \epsilon_{sh} \leq \epsilon_s < \epsilon_{su} \text{ then } f_s = f_{ue} - (f_{ue} - f_{ye}) \left( \frac{\epsilon_{su} - \epsilon_s}{\epsilon_{su} - \epsilon_{sh}} \right)^2 \quad (6-27)$$

Where:

$f_s$  Reinforcement steel stress (ksi)

$E_s$  Steel elastic modulus (ksi)

$\epsilon_s$  Reinforcement steel strain (in/in)

$f_{ye}$  Expected yield strength of reinforcement steel (ksi)

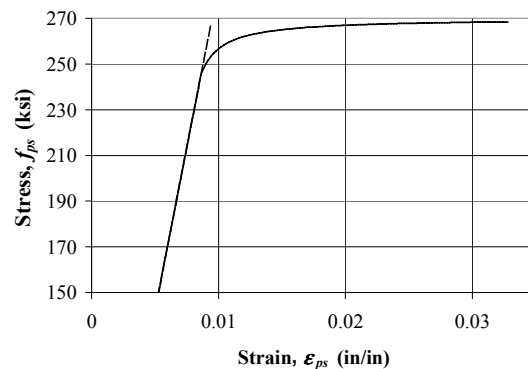
$f_{ue}$  Expected ultimate tensile strength of reinforcement steel (ksi)

$\epsilon_{su}$  Ultimate tensile strain of steel reinforcement (in/in)

$\epsilon_{sh}$  Onset of strain hardening of steel reinforcement (in/in)

### 6.6.3 Nonlinear Prestressing Strand Model

Prestressing strands shall be modeled with an idealized nonlinear stress strain model. Figure 6.8 is an idealized stress-strain model for 7-wire low-relaxation Grade 270 prestressing strand.



**Figure 6.8 Grade 270 Low Relaxation Prestressing Strand Stress-Strain Model**

The Grade 270 low relaxation prestressing strand stress strain curve is modeled using the following equations.

$$\text{If } \epsilon_{ps} \geq 0.0086 \text{ in/in } f_{ps} = 270 - \frac{0.04}{\epsilon_{ps} - 0.007} \quad (6-28)$$

$$\text{If } \epsilon_{ps} < 0.0086 \text{ in/in } f_{ps} = 28,500 \epsilon_{ps} \quad (6-29)$$

Where:

- $f_{ps}$  Prestressing steel stress (ksi)
- $\epsilon_{ps}$  Prestressing steel strain (in/in)

The ultimate prestressing steel strain is as follows:

$$\epsilon_{psu} = 0.035 \text{ in/in}$$

The modulus of elasticity of the prestressing steel,  $E_{ps}$ , should be taken as 28,500 ksi.

### 6.6.4 Unconfined Concrete Model

The unconfined concrete is modeled using the equations established by the research of J.B. Mander and M.J.N. Priestly (Equations 6-31 to 6-34). The strength of unconfined concrete is assumed to increase with the strain to the maximum compressive stress, decrease in a parabolic manner from the maximum compressive stress until the strain reaches  $2\epsilon_{cu}$ , then decreases linearly to zero at the spalling strain (see Figure 6.9).

$$f'_{ce} = 1.3f'_c \geq 5 \text{ ksi} \tag{6-30}$$

Where:

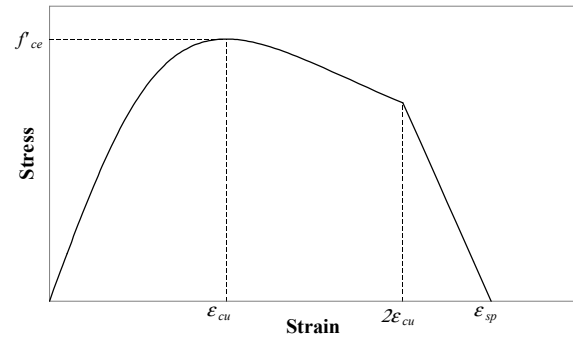
- $f'_{ce}$  Expected maximum concrete compressive strength (ksi)
- $f'_c$  Specified concrete compressive strength (ksi)

The unconfined concrete strain at maximum stress ( $\epsilon_{cu}$ ) is estimated to occur at 0.002 in/in regardless of concrete strength. The spalling strain for the unconfined concrete ( $\epsilon_{sp}$ ) is assumed to be 0.005 in/in regardless of concrete strength. The yield strain of the unconfined concrete ( $\epsilon_{cy}$ ) is typically assumed to be 70% of the strain at maximum stress or 0.0014 in/in.

$$\epsilon_{cu} = 0.002 \text{ in/in}$$

$$\epsilon_{sp} = 0.005 \text{ in/in}$$

$$\epsilon_{cy} = 0.0014 \text{ in/in}$$



**Figure 6.9 Unconfined Concrete Stress-Strain Model**

$$f_c = \frac{f'_{ce} x^r}{r - 1 + x^r} \text{ for } (\epsilon_c < 2\epsilon_{cu}) \tag{6-31}$$

$$x = \frac{\epsilon_c}{\epsilon_{cu}} \tag{6-32}$$

$$r = \frac{E_{ce}}{E_{ce} - E_{sec}} \tag{6-33}$$

$$E_{sec} = \frac{f'_{ce}}{\epsilon_{cu}} \tag{6-34}$$

Where:

- $f_c$  Stress in concrete (ksi)
- $x$  Ratio of concrete strain to maximum strain (dimensionless)
- $r$  Modulus of elasticity ratio (dimensionless)
- $E_{sec}$  Secant modulus of concrete at peak stress (ksi)
- $\epsilon_{cu}$  Unconfined concrete strain at maximum stress (in/in)
- $f'_{ce}$  Expected maximum concrete compressive strength (ksi)
- $\epsilon_c$  Concrete strain (in/in)
- $E_{ce}$  Elastic modulus of concrete using expected material properties (ksi)

### 6.6.5 Confined Concrete Model

The stress strain curve for the confined concrete is modeled using Mander's equations for the confined concrete and Priestley's formula for maximum strain. See Figure 6.10 for the typical confined concrete stress-strain model. This model shows the confined concrete strength increasing with strain up to the confined concrete compressive strength ( $f'_{cc}$ ) similar to the unconfined concrete. However, the confinement provided by the transverse reinforcement does not allow the concrete to spall away. Therefore, although the concrete does lose strength with increasing strain, the strength does not drop to zero. The confined concrete is considered to

fail in this model when the strain in the transverse reinforcement reaches the failure point.

The following equations can be used to predict the maximum confined concrete strength, the strain at the maximum strength and the confined concrete stress at any intermediate concrete strain.

$$f_c = \frac{f'_{cc} x^r}{r - 1 + x^r} \quad (6-35)$$

$$x = \frac{\epsilon_c}{\epsilon_{cc}} \quad (6-36)$$

$$r = \frac{E_{ce}}{E_{ce} - E_{sec}} \quad (6-37)$$

$$E_{sec} = \frac{f'_{cc}}{\epsilon_{cc}} \quad (6-38)$$

$$f'_{cc} = f'_{ce} \left( 2.254 \sqrt{1 + \frac{7.94 f'_l}{f'_{ce}}} - \frac{2 f'_l}{f'_{ce}} - 1.254 \right) \quad (6-39)$$

$$\epsilon_{cc} = \epsilon_{cu} \left[ 1 + 5 \left( \frac{f'_{cc}}{f'_{ce}} - 1 \right) \right] \quad (6-40)$$

$$f'_l = \frac{1}{2} k_e \rho_s f_{yh} \quad (6-41)$$

$$k_e = \frac{\left( 1 - \frac{s'}{2D'} \right)^2}{1 - \rho_{cc}} \quad \text{[for hoops]} \quad (6-42)$$

$$k_e = \frac{1 - \frac{s'}{2D'}}{1 - \rho_{cc}} \quad \text{[for spiral]} \quad (6-43)$$

$$\rho_s = \frac{4A_v}{D' s} \quad (6-44)$$

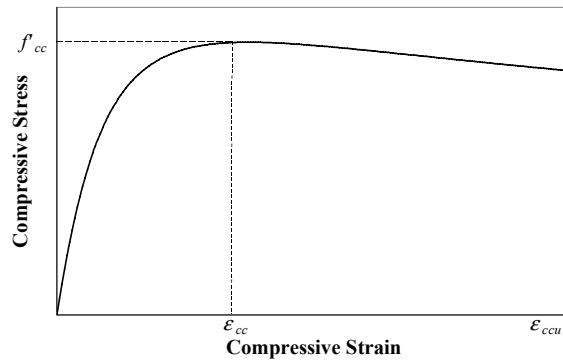
$$\rho_{cc} = \frac{4A_{st}}{\pi D'^2} \quad (6-45)$$

$$\epsilon_{ccu} = 0.004 + \frac{1.4 \rho_s \epsilon_{su}^R}{f'_{cc}} \quad (6-46)$$

$$\epsilon_{ccy} = \frac{1.8 f'_{cc}}{E_{ce}} \quad (6-47)$$

Where:

- $f_c$  Stress in concrete (ksi)
- $x$  Ratio of concrete strain to maximum strain (dimensionless)
- $r$  Modulus of elasticity ratio (dimensionless)
- $E_{sec}$  Secant modulus of concrete at peak stress (ksi)
- $f'_{cc}$  Peak stress of confined concrete (ksi)
- $\epsilon_{cc}$  Strain at maximum confined concrete stress (in/in)
- $f'_l$  Effective lateral confining stress (ksi)
- $k_e$  Confinement effectiveness coefficient (dimensionless)
- $\rho_s$  Volumetric ratio of transverse reinforcement (dimensionless)
- $\rho_{cc}$  Longitudinal reinforcement ratio (dimensionless)
- $\epsilon_{cu}$  Unconfined concrete strain at maximum stress (in/in)
- $f'_{ce}$  Expected maximum concrete compressive strength (ksi)
- $f_{yh}$  Transverse reinforcement expected yield stress (ksi)
- $\epsilon_c$  Concrete strain (in/in)
- $E_{ce}$  Elastic modulus of concrete using expected material properties (ksi)
- $s'$  Clear spacing between spirals or hoops (in)
- $s$  Transverse reinforcement spacing (in)
- $A_v$  Area of transverse reinforcement bars (in<sup>2</sup>)
- $D'$  Confined core diameter of a column or effective depth of a rectangular member (in)
- $A_{st}$  Total area of longitudinal reinforcement in the column/shaft (in<sup>2</sup>)
- $\epsilon_{ccu}$  Ultimate confined concrete compressive strain, defined as strain at first hoop fracture (in/in)
- $\epsilon_{su}^R$  Reduced ultimate tensile strain of steel reinforcement (in/in)



**Figure 6.10 Confined Concrete Stress-Strain Model**

**6.6.6 Structural Steel Material Properties**

For rolled structural steel shapes, the following material properties should be used to model the stress strain curve of Grade 50 steel unless the manufacturer or the Department provides other data.

- $E_s = 29,000$  ksi
- $F_y = 50$  ksi
- $\epsilon_{sh} = 0.01$  in/in
- $\epsilon_{su} = 0.18$  in/in

**6.6.7 Normal Weight Portland Cement Concrete Properties**

The Elastic modulus of concrete shall be computed as follows:

$$E_c = 33000w_c^{1.5}\sqrt{f'_c} \tag{6-48}$$

$$E_{ce} = 33000w_c^{1.5}\sqrt{f'_{ce}} \tag{6-49}$$

Where:

- $f'_c$  Specified concrete compressive strength (ksi)
- $f'_{ce}$  Expected maximum concrete compressive strength (ksi)
- $w_c$  Density of normal weight concrete (kcf)  
 $w_c = 0.145$  when  $f'_c \leq 5$  ksi  
 $w_c = 0.140 + 0.001f'_c$  when  $15\text{ksi} > f'_c > 5$  ksi
- $E_c$  Elastic modulus of concrete (ksi)
- $E_{ce}$  Elastic modulus of concrete using expected material properties (ksi)

The Elastic modulus of the concrete is computed using Equation 6-48 for specified concrete properties or Equation 6-49 for the expected material properties to be consistent with other material property calculations.

**6.6.8 Sand-Lightweight Concrete Properties**

Sand-lightweight concrete is sometimes used in deck slabs to reduce superstructure weight. The material properties of sand-lightweight concrete shall be established and submitted to the RPG Structural Group in consultation with the Structural Design Support Engineer for approval.

**6.6.9 Other Material Properties**

Inelastic behavior shall be limited to pre-determined locations. The material properties and stress-strain relationships for non-standard components shall be included in the project specific design criteria.

**6.7 PLASTIC MOMENT CAPACITY FOR DUCTILE CONCRETE MEMBERS**

The plastic moment capacity of all ductile concrete members shall be calculated by moment-curvature ( $M-\phi$ ) analysis using expected material properties. Moment-curvature analysis provides a curvature associated with a moment for a cross section based on the principles of strain compatibility and equilibrium of forces. Several computerized programs are available to perform the moment-curvature analysis.

**6.7.1 Analytical Modeling of Composite Section**

In some cases, a substructure element may be comprised of more than one material. A prestressed concrete pile with a stinger for example has a portion of its length comprised of both the prestressed concrete and the HP stinger. If this portion represents a significant percentage (>20%) of the total pile length, this composite section should be included in the overall model. Given that the HP stinger is typically embedded in the prestressed concrete for only 6', this composite section is typically modeled as a prestressed concrete section.

**6.7.2 Interpretation of Analysis Results**

The moment curvature analysis of a section will result in a series of data points for the moment with increasing curvature. From this data the following information is used to help further analyze and design the structure.

- $M_p$  Plastic moment capacity of column, pile or drilled shaft (k-in)
- $\phi_p$  Idealized plastic moment curvature ( $\text{in}^{-1}$ )
- $M_{max}$  Maximum moment for the section (could be equal to the ultimate moment) (k-in)
- $\phi_{max}$  Curvature at maximum moment (could be equal to the ultimate curvature) ( $\text{in}^{-1}$ )

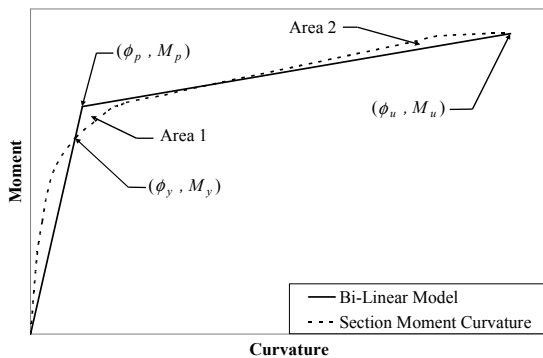


- $M_{sh}$  Moment at the idealized onset of strain hardening (k-in)
- $\phi_{sh}$  Curvature at idealized onset of strain hardening ( $\text{in}^{-1}$ )
- $M_u$  Ultimate moment (point where section reaches failure) (k-in)
- $\phi_u$  Curvature at failure defined as confined concrete strain reaching  $\epsilon_{ccu}$  or the confinement reinforcement steel reaching the ultimate strain  $\epsilon_{su}$  ( $\text{in}^{-1}$ )

Some analysis packages make reference to the "Idealized Yield Moment" or "Effective Yield Moment". Both are equivalent to the Plastic Moment.

**6.7.3 Reinforced Concrete Moment Curvature ( $M-\phi$ ) Analysis**

The  $M-\phi$  curve for conventionally reinforced concrete sections can be idealized with a bi-linear curve representing the elastic and plastic response of the section. The elastic portion of the idealized curve should pass through the point marking the first reinforcement bar yield. The idealized plastic moment capacity is obtained by balancing the areas (labeled Area 1 and Area 2) between the actual and the idealized  $M-\phi$  curves beyond the first reinforcement bar yield point (see Figure 6.11).

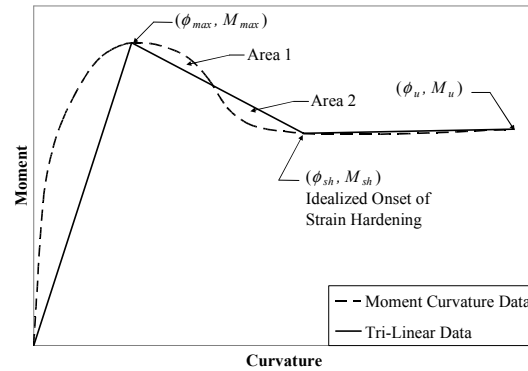


**Figure 6.11 Bi-Linear Moment Curvature Curve for Reinforced Concrete Sections**

**6.7.4 Prestressed Concrete Moment Curvature ( $M-\phi$ ) Analysis**

The  $M-\phi$  curve, for prestressed concrete pile sections, can be idealized with a tri-linear curve representing the elastic, spalling and plastic response of the section. The elastic portion of the curve is assumed to terminate at the point of maximum moment. The portion of the curve representing the spalling of the unconfined concrete goes from the maximum

moment to a user-defined point along the curve data (Idealized onset of strain hardening), which visually balances the areas (labeled Area 1 and Area 2) above and below the curve (see Figure 6.12).

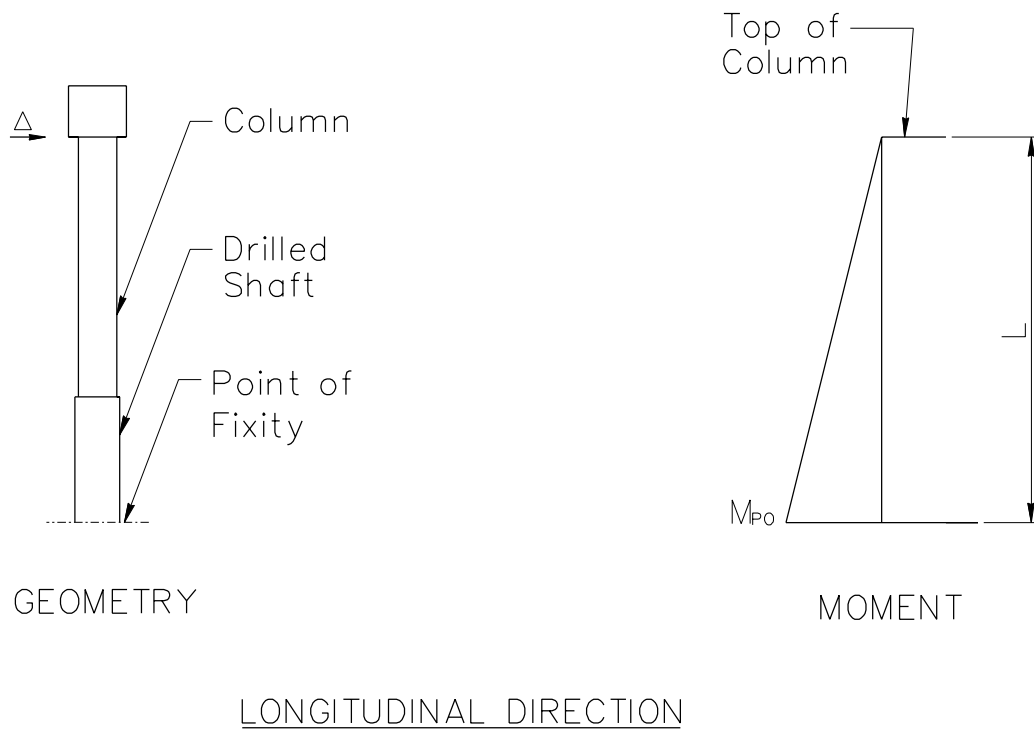
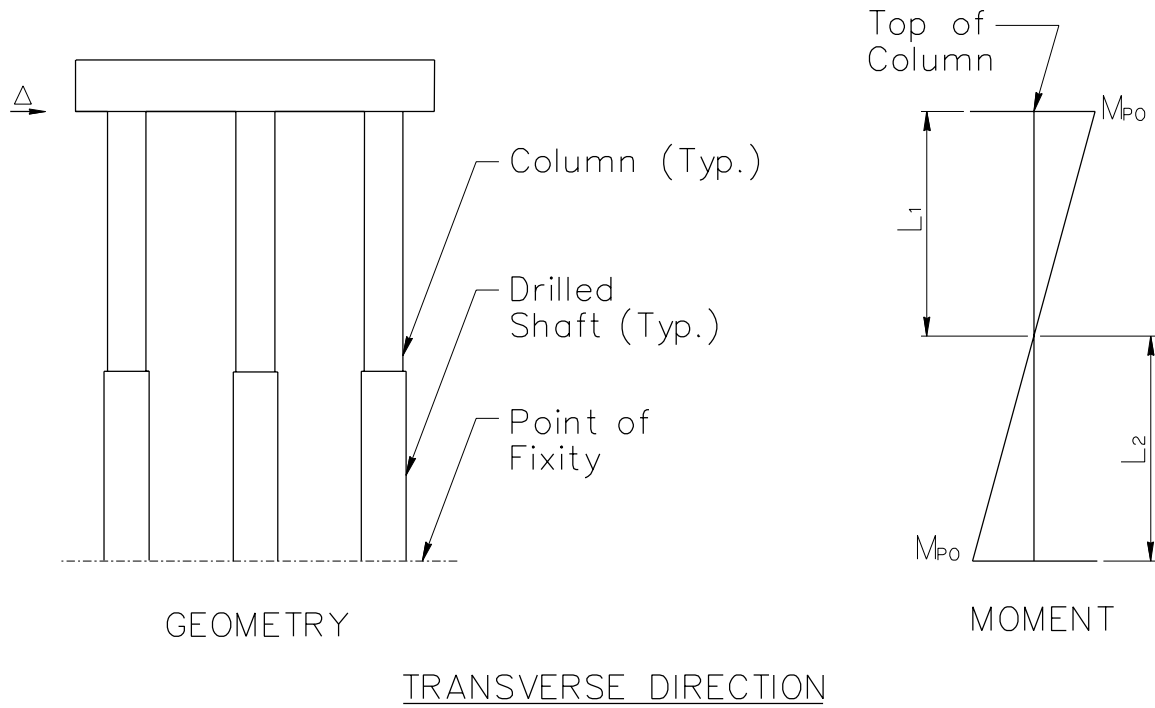


**Figure 6.12 Tri-Linear Moment Curvature Curve for Prestressed Concrete Pile Sections**

**6.7.5 Shear and Moment Capacity**

In order to determine the force demands on essentially elastic members, a 20% overstrength magnifier shall be applied to the plastic moment capacity of the column to account for the following:

- Material strength variations between the column and adjacent members (bent caps, footings, oversized drilled shafts, etc.).
- Column moment capacities greater than the plastic moment capacity.



**Figure 6.13 Moment Diagram for SCDOT Typical Multi-Column Bent**

Equation 6-50 is for the overstrength moment and Equations 6-51 and 6-52 compute the overstrength shear force for either a fixed-fixed condition as shown in Figure 6.4, or a free-fixed condition as shown in Figure 6.3, respectively. See Figure 6.13 for more details.

$$M_{po} = 1.2M_p \quad (6-50)$$

$$V_{po} = \frac{2M_{po}}{(L_1 + L_2)} \quad (6-51)$$

$$V_{po} = \frac{M_{po}}{L} \quad (6-52)$$

Where:

- $M_{po}$  Overstrength plastic hinge moment (k-in)
- $V_{po}$  Overstrength plastic hinge shear force (k)
- $L$  Distance from the point of maximum moment to the point of contraflexure (in)
- $L_1$  Length of column from top of column to point of contraflexure (in)
- $L_2$  Length of column from the point of contraflexure to the bottom of column (in)

## 6.8 PUSH-OVER ANALYSIS

Push-over analysis, sometimes referred to as inelastic static analysis, is an incremental linear analysis, which captures the overall nonlinear behavior of the substructure elements, including soil effects, by pushing them laterally to initiate plastic action. Each increment pushes the frame laterally until the potential collapse mechanism is achieved.

Because the analytical model accounts for the redistribution of internal actions as components respond inelastically, push-over analysis is expected to provide a more realistic measure of behavior than can be obtained from elastic analysis procedures. This analysis is typically performed using the expected material properties (see Section 6.6).

Since the superstructure is assumed to behave elastically, the substructure elements are the only elements to be modeled inelastically.

### 6.8.1 Load-Displacement (P-Y) Curves

P-Y curves are modeled as springs in the pushover analysis of the substructure to represent the soil properties. The springs are placed along the substructure elements, where needed, to represent the effects of the surrounding soil.

P-Y curves are obtained from soil-structure interaction analysis programs. These curves are dependent on the soil properties and depth of soil layers. P-Y curves typically vary linearly with depth within a uniform soil layer. Since the curves are dependent on the soil type, the more soil layers that are present at the site, the more P-Y curves will be required to model the soil. The P-Y information is typically reported as load per unit length of pile vs. displacement, see Figure 6.14.

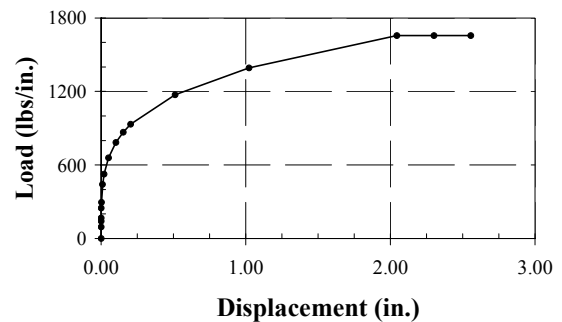


Figure 6.14 Example P-Y Curve

P-Y curves are typically broken down into elastic and plastic segments. This is done by selecting a yield point for the bi-linear approximation that balances area 1 and area 2 shown in Figure 6.15.

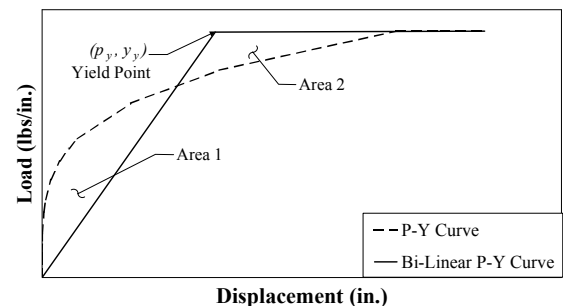


Figure 6.15 Bi-Linear P-Y Curve Approximation

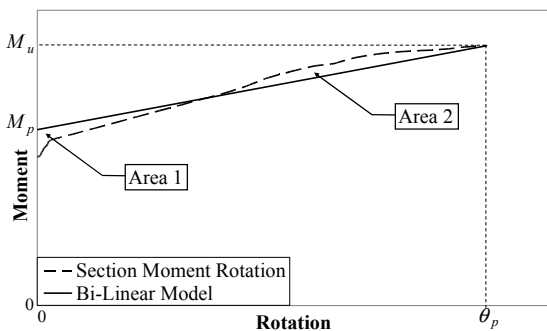
### 6.8.2 Moment Rotation Hinges

A moment rotation hinge is used to model the plastic behavior of the substructure during a pushover analysis. In modeling most substructures, two types of hinge may be required.

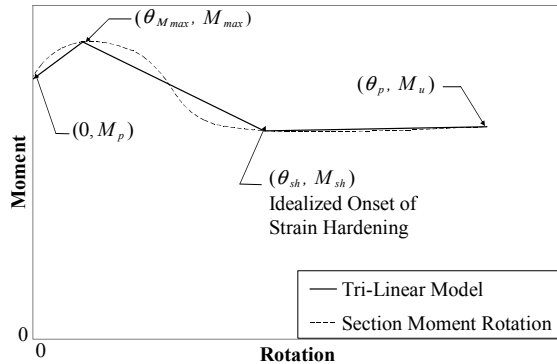
The first moment rotation hinge type is the "fixed" hinge. This hinge is used to model a fixed connection between a pile or column and the bent cap as well as the connection between a footing or oversized drilled shaft and the column or pile.

In this type of connection, the moment is assumed to build up without any rotation of the column until the plastic moment, as obtained from moment curvature analysis of the section, is reached. The rotation begins from this point and increases with the moment until the plastic rotation is obtained.

The bi-linear moment rotation curve is typically used for the conventionally reinforced concrete columns and HP sections (see Figure 6.16). The tri-linear moment rotation curve is typically used for prestressed concrete piles (see Figure 6.17).

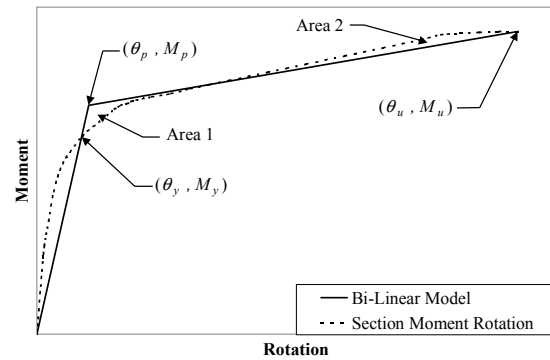


**Figure 6.16 Bi-Linear Moment Rotation Curve (Fixed Hinge)**

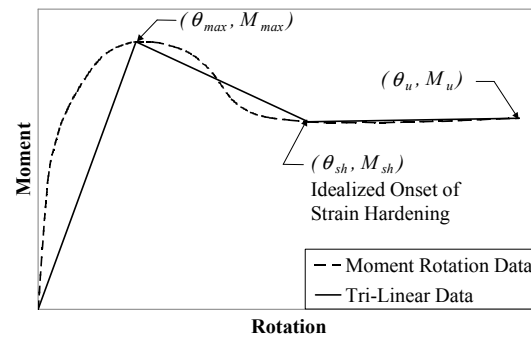


**Figure 6.17 Tri-Linear Moment Rotation Curve (Fixed Hinge)**

The second moment rotation hinge type is the "free" hinge. This hinge is used to model any other location or connection along the column. With this hinge, rotation is assumed to increase with the moment. The bi-linear curve for conventionally reinforced concrete and the tri-linear moment rotation curve for prestressed concrete piles are shown in Figures 6.18 and 6.19 respectively.



**Figure 6.18 Bi-Linear Moment Rotation Curve (Free Hinge)**



**Figure 6.19 Tri-Linear Moment Rotation Curve (Free Hinge)**

**6.9 REQUIREMENTS FOR CAPACITY-PROTECTED COMPONENTS**

As discussed in Section 6.3, plastic hinging is only allowed in the column, drilled shaft or pile substructure elements. The members to which these columns or piles are connected, footings, bent caps and oversized drilled shafts, are therefore designed to remain essentially elastic. These elements that are designed to remain essentially elastic are called "capacity-protected".

Capacity-protected concrete components such as footings, oversized drilled shafts and bent caps shall be designed to remain essentially when the column or pile reaches its overstrength flexural capacity. The nominal moment capacity ( $M_{ne}$ ) for capacity-protected concrete components is the minimum requirement for essentially elastic behavior.  $M_{ne}$  shall be determined by either  $M-\phi$  or strength design based on expected material properties.

Expected material properties shall be used to assess the component flexural capacity for resisting earthquake loads, but material properties used for assessing all other load cases shall comply with the SCDOT Bridge Design Manual.

Expected nominal moment capacity for capacity-protected concrete components shall be based on the expected concrete and steel strengths when either the concrete strain reaches 0.002 or the reinforcement steel strain reaches  $\epsilon_{ye}$  as defined in the steel stress-strain model (see Section 6.6.2).



## **Section 7**

# **DEMAND VERSUS CAPACITY**

**SCDOT Seismic Design Specifications for Highway Bridges**





**TABLE OF CONTENTS**

**SECTION 7 - DEMAND VERSUS CAPACITY.....7-1**

7.1 PERFORMANCE CRITERIA..... 7-1

    7.1.1 Global Displacement Criteria ..... 7-1

    7.1.2 Ductility Demand..... 7-1

    7.1.3 Ductility Capacity ..... 7-1

7.2 P- $\Delta$  EFFECTS..... 7-1



## SECTION 7 - DEMAND VERSUS CAPACITY

### 7.1 PERFORMANCE CRITERIA

#### 7.1.1 Global Displacement Criteria

The global structure displacement,  $\Delta_d$ , is the total displacement at a particular location within the structure. The global displacement will include components attributed to foundation flexibility (i.e. foundation rotation or translation), flexibility of essentially elastic components such as bent caps, and the flexibility attributed to the elastic response of ductile members. The analytical model for determining the displacement demands shall include as many of the structural characteristics and boundary conditions affecting the structure's global displacements as possible. Section 5 details the determination of the displacement demand while Section 6 details the determination of the displacement capacity.

Each bridge unit shall satisfy Equation 7-1.

$$\Delta_d < \Delta_c \quad (7-1)$$

Where:

$\Delta_d$  Displacement demand (in)  
 $\Delta_c$  Displacement capacity (in)

#### 7.1.2 Substructure Unit Ductility Demand

Ductility demand is a measure of the imposed plastic deformation on a structure. The ductility demand is a function of the displacement demand (see Section 5) and the yield displacement from the pushover analysis (see Section 6). Ductility demand is mathematically defined by Equation 7-2.

$$\mu_d = \frac{\Delta_d}{\Delta_y} \quad (7-2)$$

Where:

$\mu_d$  Ductility demand (dimensionless)  
 $\Delta_d$  Displacement demand (in)  
 $\Delta_y$  Yield displacement (in)

For the purpose of ductility computations, the yield displacement used in equations 7-2 and 7-3, shall be the idealized yield displacement. The idealized yield displacement is that displacement which corresponds to the effective or idealized yield moment as obtained from a  $M-\phi$  analysis of the section.

For conventional ductile design, the ductility shall be limited to the values shown in Table 7.1.

#### 7.1.3 Ductility Capacity

Ductility capacity for a particular bent or end bent is defined using Equation 7-3.

$$\mu_c = \frac{\Delta_c}{\Delta_y} \quad (7-3)$$

Where:

$\mu_c$  Ductility capacity (dimensionless)  
 $\Delta_c$  Displacement capacity (in)  
 $\Delta_y$  Yield displacement (in)

Each interior bent or end bent shall have a minimum displacement ductility capacity of  $\mu_c = 3$  to ensure dependable rotational capacity in the plastic hinge regions regardless of the displacement demand imparted to that member.

The minimum displacement ductility capacity of 3 may be difficult to achieve for columns and drilled shafts with large diameters ( $D > 10'$ ), or components with large L/D ratios. Displacement ductility capacities less than 3 require the approval of the Department RPG Structural Engineer in consultation with the Structural Design Support Engineer.

### 7.2 P-Δ EFFECTS

The dynamic effects of gravity loads acting through lateral displacements shall be included in the design of interior bents. The magnitude of displacements associated with P-Δ effects can only be accurately captured with non-linear time history or pushover analysis. In lieu of such analysis, Equation 7-4 can be used to establish a conservative limit for lateral displacements induced by axial load. If Equation 7-4 is satisfied, P-Δ effects can typically be ignored.

$$P_{dl} \Delta_r \leq 0.25 M_p \quad (7-4)$$

Where:

$P_{dl}$  Axial dead load in column/pile (k)  
 $\Delta_r$  The relative lateral offset between the point of contraflexure and the end of the plastic hinge (in)  
 $M_p$  Plastic moment capacity of column, pile or drilled shaft (k-in)

**Table 7.1 Substructure Unit Quantitative Damage Criteria (Maximum Ductility Demand  $\mu_d$ )**

Bridge System		Design Earthquake	Operational Classification (OC)		
			I	II	III
Superstructure		FEE	1.0	1.0	See Note
		SEE	1.0	1.0	1.0
Substructure	Prestressed Concrete Pile Interior Bents	FEE	2.0	4.0	See Note
		SEE	4.0	8.0	8.0
	Prestressed Concrete Pile End Bents	FEE	1.0	4.0	See Note
		SEE	2.0	8.0	8.0
	Single Column Bents	FEE	2.0	3.0	See Note
		SEE	3.0	6.0	8.0
	Multi Column Bents	FEE	2.0	3.0	See Note
		SEE	4.0	8.0	8.0
	Pier Walls Weak Axis	FEE	2.0	3.0	See Note
		SEE	3.0	6.0	8.0
	Pier Walls Strong Axis	FEE	1.0	1.0	See Note
		SEE	1.0	1.0	2.0

Note: Analysis for FEE is not required for OC III bridges.

## **Section 8**

# **CAST-IN-PLACE CONCRETE DESIGN AND DETAILING**

**SCDOT Seismic Design Specifications for Highway Bridges**



**TABLE OF CONTENTS**

**SECTION 8 – CAST-IN-PLACE CONCRETE DESIGN AND DETAILING ..... 8-1**

8.1 SDC A AND SINGLE SPAN BRIDGES MINIMUM REQUIREMENTS ..... 8-1

8.2 SDC B, C AND D BRIDGES MINIMUM REQUIREMENTS ..... 8-1

    8.2.1 Force Demands for Substructure Units Behaving Elastically ..... 8-1

    8.2.2 Force Demands For Capacity Protected Elements ..... 8-1

    8.2.3 Column Flexural Demands ..... 8-1

    8.2.4 Column Shear Demand ..... 8-1

    8.2.5 Pier Wall Shear Demand ..... 8-1

8.3 VERTICAL GROUND MOTION DETAILING ..... 8-1

8.4 DUCTILE MEMBER DESIGN REQUIREMENTS FOR SDC B, C AND D ..... 8-2

    8.4.1 Minimum Lateral Strength ..... 8-2

    8.4.2 Maximum Axial Load in a Ductile Member ..... 8-2

    8.4.3 Maximum Longitudinal Reinforcement ..... 8-2

    8.4.4 Minimum Longitudinal Reinforcement ..... 8-2

    8.4.5 Splicing of Longitudinal Reinforcement in Columns ..... 8-2

    8.4.6 Minimum Development Length of Longitudinal Column Reinforcement ..... 8-3

    8.4.7 Anchorage of Bundled Bars in Ductile Components ..... 8-3

    8.4.8 Maximum Bar Diameter ..... 8-3

    8.4.9 Minimum Development Length of Longitudinal Column Reinforcement Extended into Oversized Shafts ..... 8-3

    8.4.10 Transverse Reinforcement Inside the Plastic Hinge Region ..... 8-3

    8.4.11 Transverse Reinforcement Outside the Plastic Hinge Region ..... 8-3

    8.4.12 Maximum Spacing for Transverse Reinforcement ..... 8-3

    8.4.13 Transverse Reinforcement Requirements for Columns on Oversized Drilled Shafts ..... 8-4

    8.4.14 Transverse Confinement for Oversized Drilled Shafts ..... 8-4

    8.4.15 Lateral Confinement for Non-Oversized Strengthened Drilled Shafts ..... 8-4

8.5 CAPACITY PROTECTED ELEMENT DESIGN REQUIREMENTS ..... 8-4

8.6 SHEAR DESIGN ..... 8-8

    8.6.1 Concrete Subject to Flexure and Compression ..... 8-8

    8.6.2 Strength of Transverse Reinforcement ..... 8-8

8.7 BENT CAP JOINT SHEAR DESIGN ..... 8-9

    8.7.1 Principal Stresses in Connections ..... 8-9

    8.7.2 Maximum Allowable Principal Stress ..... 8-10

    8.7.3 Minimum Required Horizontal Reinforcement ..... 8-12

    8.7.4 Conventional Bent Cap-Column Joints ..... 8-12

    8.7.5 Vertical Reinforcement ..... 8-12

    8.7.6 Additional Cap Longitudinal Reinforcement ..... 8-12

    8.7.7 Hoop Transverse Confinement Reinforcement ..... 8-13

    8.7.8 Knee Joints ..... 8-13

8.8 FOOTING JOINT SHEAR DESIGN ..... 8-16

    8.8.1 Footing-Column Joints ..... 8-16

    8.8.2 Vertical Reinforcement ..... 8-16

    8.8.3 Horizontal Reinforcement ..... 8-16

    8.8.4 Hoop Transverse Confinement Reinforcement ..... 8-16

8.9 INTEGRAL BENT CAP JOINT SHEAR ..... 8-18

    8.9.1 Integral Superstructure-Column Joints ..... 8-18

    8.9.2 Integral Superstructure Joint Proportioning ..... 8-18

8.9.3	Vertical Reinforcement.....	8-18
8.9.4	Additional Flexural Reinforcement .....	8-18
8.9.5	Horizontal Reinforcement.....	8-18
8.9.6	Hoop Transverse Confinement Reinforcement.....	8-18



## SECTION 8 – CAST-IN-PLACE CONCRETE DESIGN AND DETAILING

### 8.1 SDC A AND SINGLE SPAN BRIDGES MINIMUM REQUIREMENTS

No detailed seismic structural analysis is required. Consideration of seismic forces is not required for the design of structural components of SDC A or Single Span Bridges except that the connection of the superstructure to the substructure shall be designed to resist a horizontal seismic force equal to the larger of 0.25 or  $S_{DI-SEE}$ , times the dead load reaction in the restrained directions.

Minimum detailing of columns, drilled shafts, connections between columns and bent caps, and connections between columns and footings, is required. See Figures 8.2 and 8.3 for details.

In addition, minimum support length shall be provided as required in Section 9.1.1.

### 8.2 SDC B, C AND D BRIDGES MINIMUM REQUIREMENTS

#### 8.2.1 Force Demands for Substructure Units Behaving Elastically

In some instances, a structure may undergo a seismic event, but due to small displacement demands, not undergo any plastic deformation. Therefore, the design forces shall be the lesser of the forces resulting from plastic hinging or the unreduced elastic seismic forces in columns or pier walls. Those forces shall be less than capacities established in this section. Initial sizing of columns can be performed using service load combinations.

#### 8.2.2 Force Demands For Capacity Protected Elements

Capacity Protected elements are defined as part of the structure that is either connected to a critical element or within its load path and that is prevented from yielding by virtue of having the critical member limit the maximum force that can be transmitted to the capacity protected element. The force demands for capacity protected elements adjacent to plastic hinging locations shall be determined by the distribution of overstrength moments and associated shear when the frame or structure reaches its Collapse Limit State.

#### 8.2.3 Column Flexural Demands

The column design moments shall be determined by the plastic moment capacity of the column,  $M_p$ . The overstrength moment  $M_{po}$  defined in Section 6.7.5 and the moment distribution characteristics of the structural system shall determine the design forces for the Essentially Elastic Components connecting to the column.

#### 8.2.4 Column Shear Demand

The column shear demand and the shear demand transferred to adjacent components shall be the overstrength shear,  $V_{po}$ , as defined in Section 6.7.5. The designer shall consider all potential plastic hinge locations to insure the maximum possible shear demand has been determined.

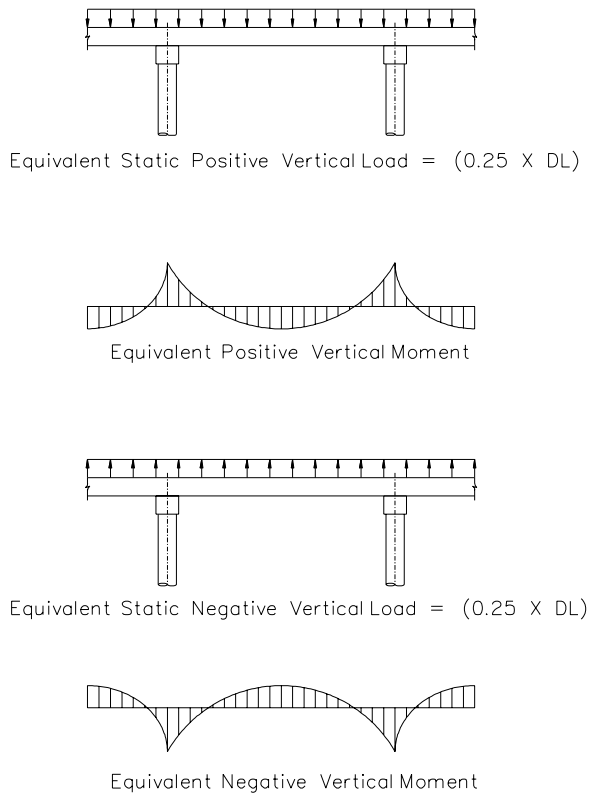
#### 8.2.5 Pier Wall Shear Demand

The shear demand for pier walls in the weak direction shall be determined in the same manner as the shear demand in columns. The shear demand for pier walls in the strong direction is dependent upon the boundary conditions of the pier wall. If foundation is designed to yield, the pier walls with fixed-fixed end conditions shall be designed to resist the lesser of the shear generated by the unreduced elastic seismic demand or 130% of the ultimate shear capacity of the foundation (based on most-probable geotechnical properties). Also, for the same selected strategy, pier walls with fixed-pinned end conditions shall be designed for 130% of the lesser of either the shear capacity of the pinned connection or the ultimate capacity of the foundation.

### 8.3 VERTICAL GROUND MOTION DETAILING

Bridges in SDC D shall have a separate analysis of the superstructure's nominal capacity performed based on a uniformly applied vertical force equal to 25% of the total dead load of the superstructure applied upward and downward, see Figure 8.1. The superstructure at non-integral end bents shall be assumed to be pinned in the vertical direction for both directions of loading. The superstructure flexural capacity shall be based only on continuous mild reinforcement distributed evenly between the top and bottom layers of the slab. The effects of dead load, primary and secondary prestressing shall be ignored. The continuous steel shall be spliced with

"service level" couplers capable of achieving a minimum strength of 75ksi, and is considered effective in offsetting the mild reinforcement required for other load cases. Lap splices equal to two times the standard lap may be substituted for the "service splices", provided the laps are placed away from the critical zones (mid-spans and near supports).



**Figure 8.1 Equivalent Static Vertical Loads and Moments**

**8.4 DUCTILE MEMBER DESIGN REQUIREMENTS FOR SDC B, C AND D**

The provisions of this section are applicable only to bridges designated SDC B to SDC D with the exception of the minimum detailing requirements for SDC A bridges as shown in Figures 8.2 and 8.3.

**8.4.1 Minimum Lateral Strength**

Each column shall have a minimum lateral flexural capacity (based on expected material properties) to resist a lateral force of  $0.1P_{dl}$ , where  $P_{dl}$  is the axial dead load effects in the column.

The requirement for pier wall flexural capacity in the weak direction is similar to a column. Piles for

which ductility demand is greater than one shall have the same requirement.

**8.4.2 Maximum Axial Load in a Ductile Member**

The maximum axial load in a column, a pier wall, or a pile where ductility demand is greater than one is computed using Equation 8-1.

$$P_{max} = 0.2f'_{ce} A_g \tag{8-1}$$

Where:

- $P_{max}$  The maximum allowable axial load applied on the column, pile, or pier wall (k)
- $f'_{ce}$  Expected maximum concrete compressive strength (ksi)
- $A_g$  Gross area of column, pile, or pier wall (in<sup>2</sup>)

**8.4.3 Maximum Longitudinal Reinforcement**

The area of longitudinal reinforcement for compression members shall not exceed the value specified by Equation 8-2.

$$A_{st} \leq 0.04A_g \tag{8-2}$$

Where:

- $A_{st}$  Total area of longitudinal reinforcement in the column/shaft (in<sup>2</sup>)
- $A_g$  Gross area of column, pile or pier wall (in<sup>2</sup>)

**8.4.4 Minimum Longitudinal Reinforcement**

The minimum area of longitudinal reinforcement for compression members shall not be less than the value specified by Equations 8-3 and 8-4.

$$A_{st} \geq 0.01A_g \quad (\text{for Columns}) \tag{8-3}$$

$$A_{st} \geq 0.005A_g \quad (\text{for Pier Walls}) \tag{8-4}$$

Where:

- $A_{st}$  Total area of longitudinal reinforcement in the column/shaft (in<sup>2</sup>)
- $A_g$  Gross area of column, pile or pier wall (in<sup>2</sup>)

**8.4.5 Splicing of Longitudinal Reinforcement in Columns**

Splicing of longitudinal column reinforcement subject to ductility demands greater than one shall be outside the plastic hinging region as provided in Section 6.4. Ultimate strength splicing of reinforcement shall be used by means of ultimate mechanical couplers approved by the Department.

#### 8.4.6 Minimum Development Length of Longitudinal Column Reinforcement

Longitudinal column reinforcement shall be extended into footings and cap beams as close as practically possible to the opposite face of the footing or cap beam.

The minimum anchorage length for longitudinal column bars developed into the cap beam or footing for seismic loads shall be computed using Equation 8-5. The anchorage length shall not be reduced by the addition of hooks or mechanical anchorage devices.

$$l_{ac} = 24d_{bl} \quad (8-5)$$

Where:

$l_{ac}$  Anchorage length for longitudinal column reinforcement (in)  
 $d_{bl}$  Longitudinal reinforcement nominal bar diameter (in)

#### 8.4.7 Anchorage of Bundled Bars in Ductile Components

The anchorage length of longitudinal column bars within bundles that are anchored into a cap beam or footing shall be increased by 20% for a two-bar bundle and 50% for a three-bar bundle. Four-bar bundles are not permitted in ductile elements.

#### 8.4.8 Maximum Bar Diameter

The nominal diameter of longitudinal reinforcement in columns shall not exceed the value computed by Equation 8-6.

$$d_{bl} \leq \frac{0.79(L - 0.5D_c)\sqrt{f'_c}}{f_{ye}} \quad (8-6)$$

Where:

$d_{bl}$  Longitudinal reinforcement nominal bar diameter (in)  
 $L$  Distance from point of maximum moment to the point of contraflexure (in)  
 $D_c$  Diameter or maximum cross sectional dimension of column (in)  
 $f_{ye}$  Expected yield strength of reinforcement steel (ksi)  
 $f'_c$  Specified concrete compressive strength (ksi)

Where longitudinal bars in columns are bundled, the requirement of Equation 8-6 shall be checked for the effective bar diameter, assumed as  $1.2d_{bl}$ , for two-bar

bundles, and  $1.5d_{bl}$  for three-bar bundles. Four-bar bundles are not permitted in ductile elements.

#### 8.4.9 Minimum Development Length of Longitudinal Column Reinforcement Extended into Oversized Shafts

Longitudinal column reinforcement shall be extended into oversized shafts in a staggered manner with the minimum embedment lengths of  $2D_{c,max}$  and  $3D_{c,max}$ , where  $D_{c,max}$  is the largest cross sectional dimension of the column. See Figure 8.4.

#### 8.4.10 Transverse Reinforcement Inside the Plastic Hinge Region

The volumetric ratio, as defined by Equation 6-44, of transverse reinforcement provided inside the plastic hinge region, defined in Section 6.2, shall be sufficient to ensure the column or pier wall has adequate shear capacity and confinement. The quantity of transverse reinforcement required in the plastic hinge region is specified in Section 8.7.7.

Transverse reinforcement shall be butt-welded hoops. Spiral reinforcement is not allowed in cast-in-place concrete columns and drilled shafts.

Hoops shall be placed around the column longitudinal reinforcement steel extended into the cap and footing. See Figures 8.2 to 8.4 for hoop reinforcement details.

#### 8.4.11 Transverse Reinforcement Outside the Plastic Hinge Region

The spacing of transverse reinforcement detailed outside of the plastic hinge region, shall not be more than twice that placed in the plastic hinge region.

#### 8.4.12 Maximum Spacing for Transverse Reinforcement

The maximum spacing for transverse reinforcement in the plastic hinge regions shall not exceed the smallest of the following or 6 inches (8 inches for bundled hoops):

- One fifth of the least dimension of the cross-section for columns and one-half of the least cross sectional dimension of piers.
- Six times the nominal diameter of the longitudinal reinforcement.

The maximum spacing for transverse reinforcement outside the plastic hinge region shall not exceed 12 inches.

#### **8.4.13 Transverse Reinforcement Requirements for Columns on Oversized Drilled Shafts**

The volumetric ratio of transverse reinforcement for columns supported on oversized drilled shafts shall meet the requirements of Section 8.7.7. At least 50% of the confinement reinforcement required at the base of the column shall extend over the entire embedded length of the longitudinal column reinforcement. See Figure 8.4.

#### **8.4.14 Transverse Confinement for Oversized Drilled Shafts**

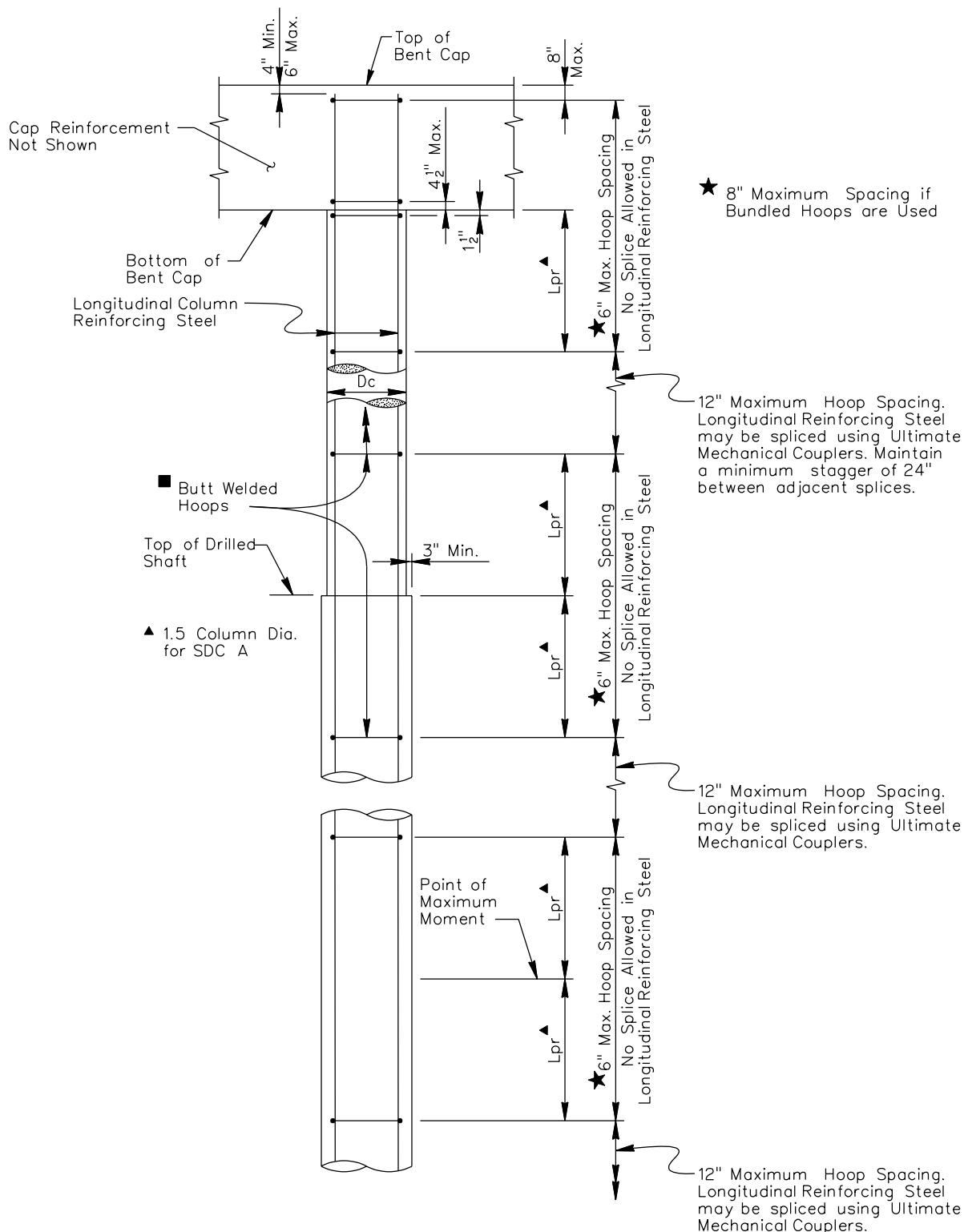
The lateral confinement in an oversized drilled shaft shall be 50% of the confinement at the base of the column provided the shaft is designed for a flexural expected nominal capacity equal to 1.25 times the moment demand generated by the overstrength moment at the base of the column. The lateral confinement shall extend along the shaft until the embedded longitudinal column reinforcement is terminated. The spacing of the oversized shaft confinement can be increased beyond the termination of the embedded column longitudinal reinforcement. See Figure 8.4.

#### **8.4.15 Lateral Confinement for Non-Oversized Strengthened Drilled Shafts**

The volumetric ratio of transverse reinforcement in the top portion,  $4D_{C,max}$ , of the drilled shaft shall be at least 75% of the transverse reinforcement required at the base of the column provided the shaft is designed for a flexural expected nominal capacity equal to 1.25 times the moment demand generated by the overstrength moment at the base of the column. The transverse confinement shall extend along the shaft until the embedded column longitudinal reinforcement is terminated. The spacing of the drilled shaft confinement reinforcement can be increased beyond the termination of the longitudinal column reinforcement. See Figure 8.2.

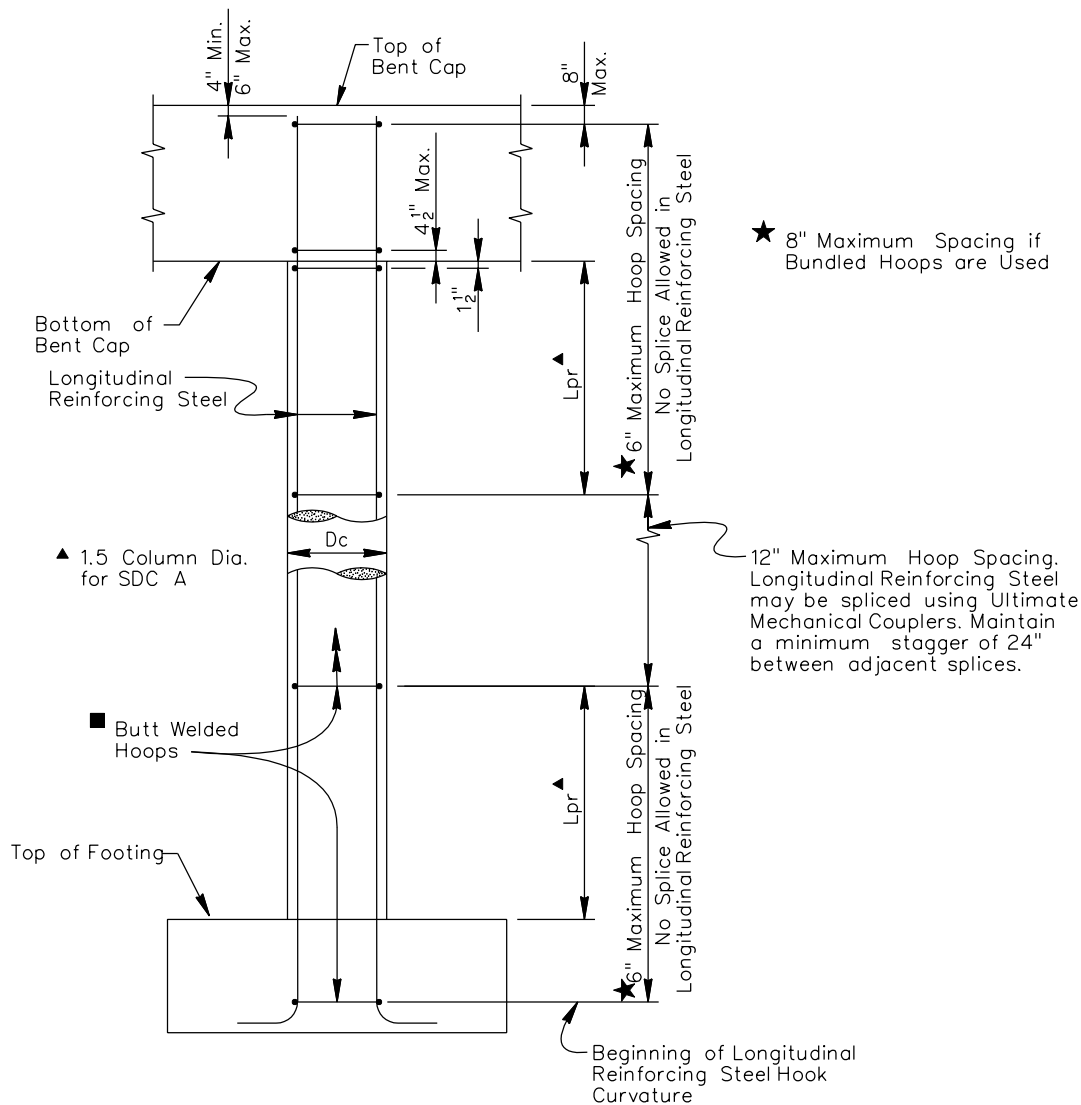
### **8.5 CAPACITY PROTECTED ELEMENT DESIGN REQUIREMENTS**

See Section 6.9.



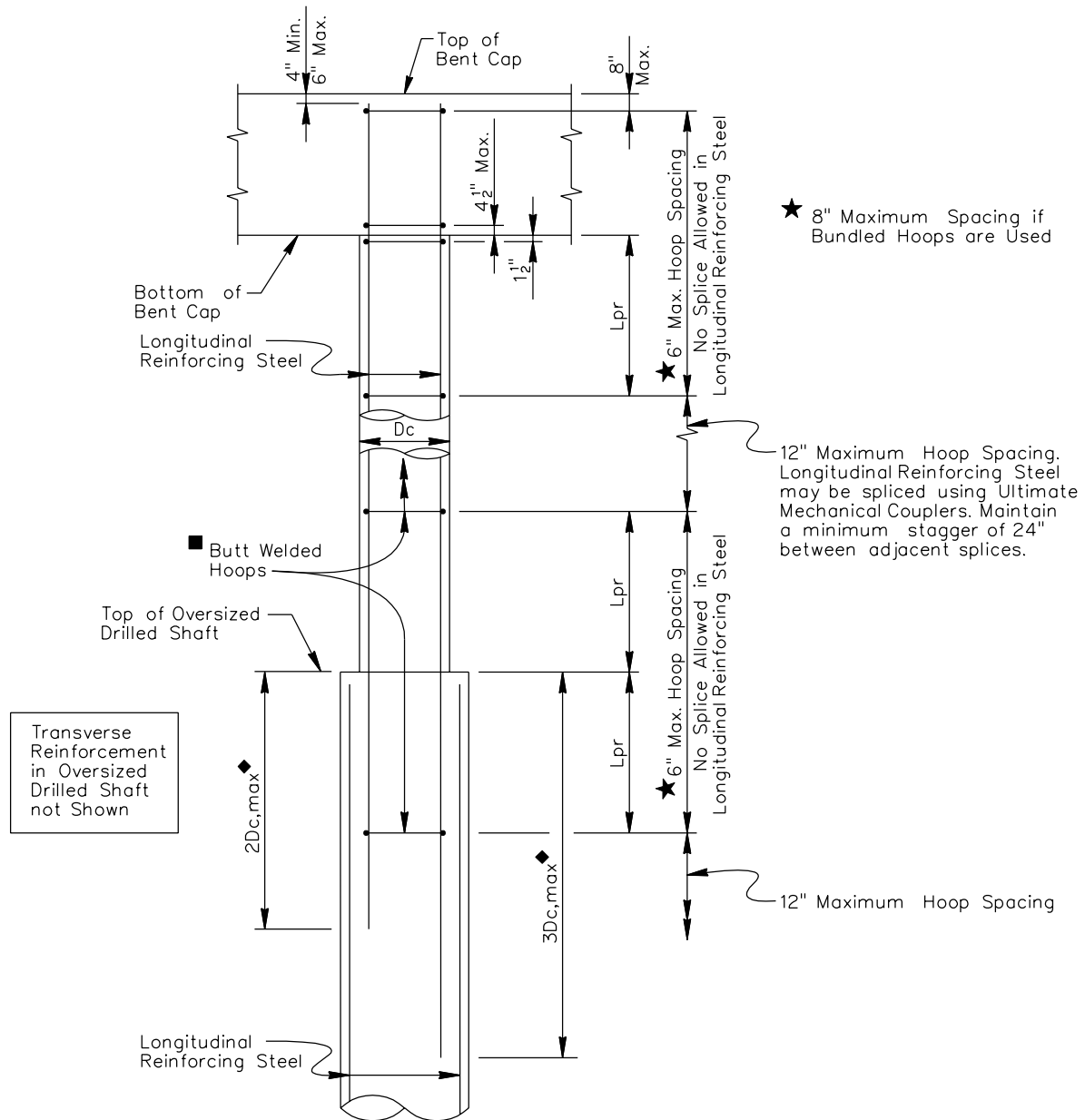
■ Hoops shall have butt welded splices. The minimum size shall be #19 (#6) and the maximum size shall be #25 (#8). To prevent the hoop weld splices from being located on the same vertical plane, the locations of the splices shall be staggered around the perimeter of the column by a minimum distance of 1/3 of the hoop circumference.

**Figure 8.2 Transverse Reinforcement for Column on a Non-oversized Drilled Shaft**



- Hoops shall have butt welded splices. The minimum size shall be #19 (#6) and the maximum size shall be #25 (#8). To prevent the hoop weld splices from being located on the same vertical plane, the locations of the splices shall be staggered around the perimeter of the column by a minimum distance of 1/3 of the hoop circumference.

**Figure 8.3 Transverse Reinforcement for a Column on a Pile Footing**



◆  $D_{c,max}$  is the largest cross sectional dimension of the column.

■ Hoops shall have butt welded splices. The minimum size shall be #19 (#6) and the maximum size shall be #25 (#8). To prevent the hoop weld splices from being located on the same vertical plane, the locations of the splices shall be staggered around the perimeter of the column by a minimum distance of  $1/3$  of the hoop circumference.

**Figure 8.4 Reinforcement for Column on Oversized Drilled Shaft**

Note: Shaft transverse reinforcement does not have the same diameter as the column transverse reinforcement

### 8.6 SHEAR DESIGN

Design of sections subjected to shear shall be based on Equation 8-7.

$$V_u \leq \phi_s (V_c + V_s) \quad (8-7)$$

Where:

- $V_u$  Smaller of elastic shear force or the overstrength plastic hinge shear force  $V_{po}$  (k)
- $V_c$  Concrete shear capacity (Section 8.6.1 or 8.6.2) (k)
- $V_s$  Reinforcement shear capacity (k) (Section 8.6.3)
- $\phi_s$  Shear strength reduction factor of 0.85 (dimensionless)

#### 8.6.1 Concrete Subject to Flexure and Compression

The concrete shear capacity,  $V_c$ , of members designed for SDC B, C and D shall be taken as:

$$V_c = v_c A_e \quad (8-8)$$

in which:

$$A_e = 0.8 A_g \quad (8-9)$$

if  $P_u$  is compressive:

$$v_c = 0.032 \alpha' \left( 1 + \frac{P_u}{2 A_g} \right) \sqrt{f'_c} \leq \min \begin{cases} 0.11 \sqrt{f'_c} \\ 0.047 \alpha' \sqrt{f'_c} \end{cases} \quad (8-10)$$

otherwise:

$$v_c = 0 \quad (8-11)$$

for circular columns with hoop reinforcing:

$$0.3 \leq \alpha' = \frac{f_s}{0.15} + 3.67 - \mu_d \leq 3 \quad (8-12)$$

$$f_s = \rho_s f_{yh} \leq 0.35 \quad (8-12a)$$

$$\rho_w = \frac{4 A_{sp}}{s D'} \quad (8-12b)$$

where:

- $A_g$  Gross area of member cross section (in<sup>2</sup>)

- $P_u$  Ultimate compressive force acting on section (kip)
- $A_{sp}$  Area of hoop reinforcing bar (in<sup>2</sup>)
- $s$  Pitch of spiral or spacing of hoops or ties (in.)
- $D'$  Diameter of spiral or hoop for circular column (in.)
- $f_{yh}$  Nominal yield stress of transverse reinforcing (ksi)
- $f'_c$  Nominal concrete compressive strength (ksi)
- $\mu_d$  Maximum local displacement ductility ratio of member

#### 8.6.2 Strength of Transverse Reinforcement

The maximum shear strength of transverse reinforcement shall not be taken greater than the limit computed using Equation 8-13.

$$V_s \leq \frac{8 A_e \sqrt{f'_c}}{1000} \quad (8-13)$$

Where:

- $V_s$  Reinforcement shear strength capacity (k)
- $A_e$  Effective shear area (in<sup>2</sup>)
- $f'_c$  Specified concrete compressive strength (psi)

The nominal shear strength of transverse reinforcement of a member with a rectangular section shall be computed by Equation 8-14. If circular confinement is used with a rectangular section, Equation 8-15 shall be used instead.

$$V_s = \frac{A_v f_y d_e}{s} \quad (8-14)$$

Where:

- $V_s$  Reinforcement shear strength capacity (k)
- $A_v$  Area of transverse reinforcement bars (in<sup>2</sup>)
- $f_y$  Specified minimum yield strength of reinforcement steel (ksi)
- $d_e$  Depth of the member (80% of member depth in the direction of the shear) (in)
- $s$  Transverse reinforcement spacing (in)



Shear reinforcement shall be placed continuously between section flexural tension and compression stress resultants.

Nominal shear resistance provided by transverse circular hoops or spiral reinforcement in circular sections shall be computed by Equation 8-15.

$$V_s = \frac{\pi A_v f_y D'}{2s} \quad (8-15)$$

Where:

$V_s$	Reinforcement shear strength capacity (k)
$A_v$	Area of transverse reinforcement bars (in <sup>2</sup> )
$f_y$	Specified minimum yield strength of transverse reinforcement steel (ksi)
$D'$	Confined core diameter of a column or effective depth of a rectangular member (in)
$s$	Transverse reinforcement spacing (in)

Nominal shear resistance provided by interlocking hoops shall be taken as the sum of the individual hoop strengths calculated in accordance with Equation 8-15.

## 8.7 BENT CAP JOINT SHEAR DESIGN

Design of beam-column joints are either single directional, resisting moments generated from seismic forces acting along the centerline of pier or bent only, or multi-directional, where special detailing allows moments to be transferred to the superstructure.

Bent caps and the moment resisting connection with the column shall be designed to resist seismic forces combined with dead load as an essentially elastic element. Connection forces shall be based on the overstrength moment,  $M_{po}$ , as defined in Section 6.7.5.

### 8.7.1 Principal Stresses in Connections

Principal stresses in any vertical plane within a pier cap to column connection shall be calculated in accordance with Equations 8-16 to 8-17.

Principal tension stress is given by Equation 8-16.

$$p_t = \frac{(f_h + f_v)}{2} - \sqrt{\left(\frac{f_h - f_v}{2}\right)^2 + v_{jh}^2} \quad (8-16)$$

Principal compression stress is given by Equation 8-17.

$$p_c = \frac{(f_h + f_v)}{2} + \sqrt{\left(\frac{f_h - f_v}{2}\right)^2 + v_{jh}^2} \quad (8-17)$$

Where:

$p_c$	Principal compressive stress (ksi)
$p_t$	Principal tensile stress (ksi)
$f_h$	Average axial horizontal stress (ksi)
$f_v$	Average axial vertical stress (ksi)
$v_{jh}$	Average joint shear stress (ksi)

The effective width of the joint depends on the shape of the column framing into the joint and is determined using Equation 8-18 or 8-19. See Figure 8-5 for details.

$$b_{je} = D_c \sqrt{2} \quad \text{for circular columns} \quad (8-18)$$

$$b_{je} = D_c + h_c \quad \text{for rectangular columns} \quad (8-19)$$

Where:

$b_{je}$	Effective joint width (in)
$D_c$	Diameter or maximum cross sectional dimension of column (in)
$h_c$	Width of column (in)

The average joint shear stress can be estimated with adequate accuracy from Equation 8-20.

$$v_{jh} = \frac{M_{po}}{h_b D_c b_{je}} \quad (8-20)$$

Where:

$v_{jh}$	Average joint shear stress (ksi)
$h_b$	The distance from c.g. of tensile force ( $T_c$ ) to c.g. of compressive force on the section (in)
$M_{po}$	Overstrength plastic hinge moment (k-in)
$D_c$	Diameter or maximum cross sectional dimension of column (in)
$b_{je}$	Effective joint width (in)

In the vertical direction, the average axial stress in the joint is provided by the axial force in the column  $P_{col}$ . An average stress at mid-height of cap or footing can be calculated using Equation 8-21 which assumes a 45° spread away from the column in all directions, as shown in Figure 8-5.

$$f_v = \frac{P_{col}}{b_{je}(D_c + h_b)} \quad (8-21)$$

Where:

$f_v$	Average axial vertical stress (ksi)
-------	-------------------------------------

$P_{col}$	Axial load including overturning effects (k)
$h_b$	Cap or footing depth (in)
$D_c$	Diameter or maximum cross sectional dimension of column (in)
$b_{je}$	Effective joint width (in)

The horizontal axial stress is based on the mean axial force at the center of the joint, including the effects of cap-beam prestress, and is computed using Equation 8-22. For most projects, this term is typically zero due to lack of prestress in the cap.

$$f_h = \frac{P_b}{b_b h_b} \quad (8-22)$$

Where:

$f_h$	Average axial horizontal stress (ksi)
$P_b$	Axial force in the cap including prestress (k)
$h_b$	Cap or footing depth (in)
$b_b$	Cap or footing width (in)

### 8.7.2 Maximum Allowable Principal Stress

The principal tension stress computed in accordance with Equation 8-16 is limited to the value obtained from Equation 8-23.

$$p_t \leq 0.379 \sqrt{f'_c} \quad (8-23)$$

Where:

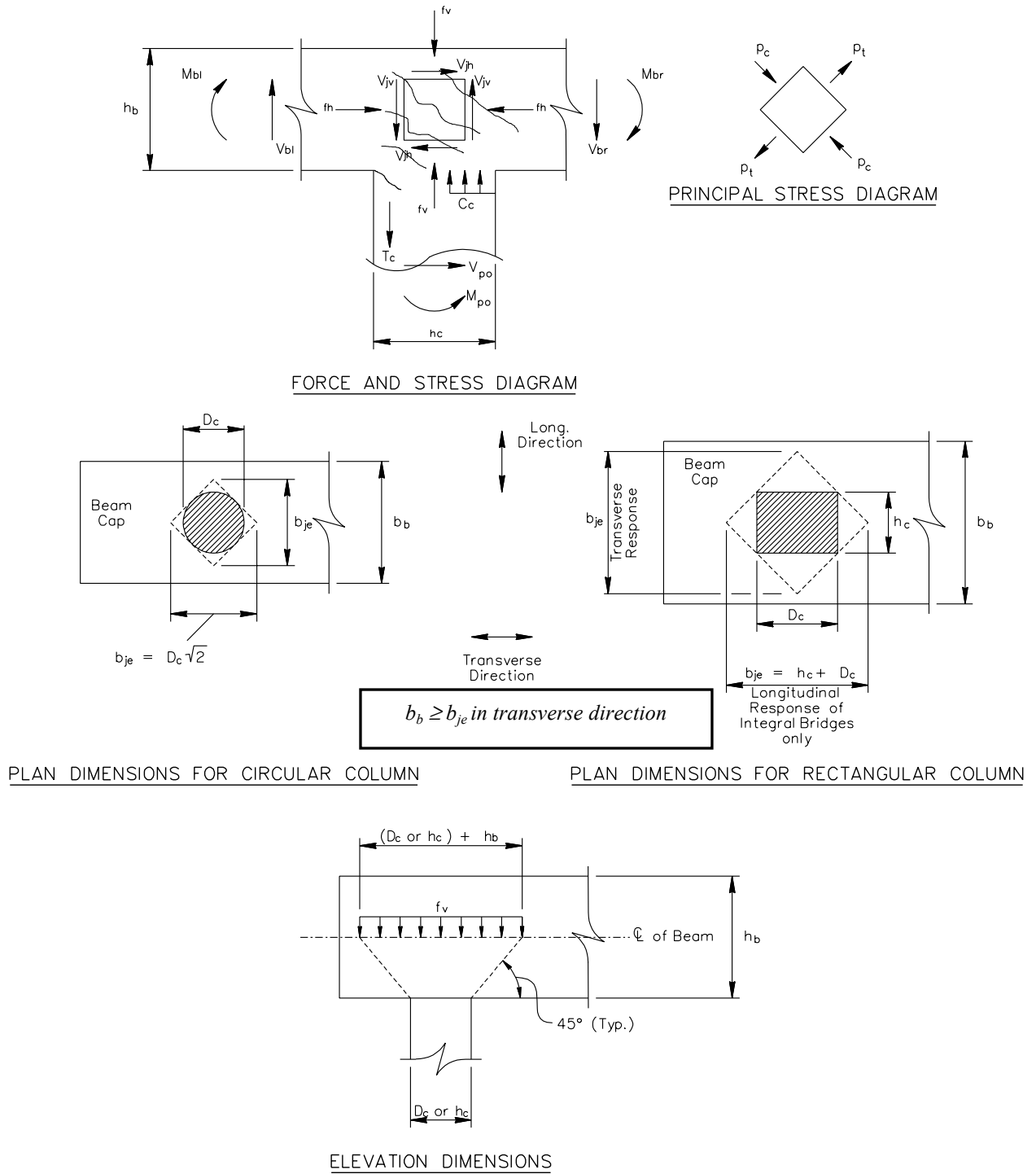
$p_t$	Principal tensile stress (ksi)
$f'_c$	Maximum concrete compressive strength (ksi)

The principal compression stress calculated in accordance with Equation 8-17 shall not exceed the value obtained from Equation 8-24.

$$p_c \leq 0.25 f'_c \quad (8-24)$$

Where:

$p_c$	Principal compressive stress (ksi)
$f'_c$	Expected maximum concrete compressive strength (ksi)



**Figure 8.5 Joint Shear Principal Stress Diagrams**

### 8.7.3 Minimum Required Horizontal Reinforcement

When the principal tension stress is less than the limit established by Equation 8-25, a minimum amount of joint shear reinforcement in the form of column hoops shall be detailed, as well as the provisions of Sections 8.7.5 through 8.7.7 shall apply.

$$p_t \leq 0.110\sqrt{f'_{ce}} \quad (8-25)$$

Where:

$p_t$	Principal tensile stress (ksi)
$f'_{ce}$	Expected maximum concrete compressive strength (ksi)

For circular columns, the minimum volumetric ratio of transverse reinforcement in the form of circular hoops to be continued into the cap or footing shall not be less than the value obtained from Equation 8-26.

$$\rho_s \geq \frac{0.110\sqrt{f'_{ce}}}{f_{yh}} \quad (8-26)$$

Where:

$\rho_s$	Volumetric ratio of transverse reinforcement (dimensionless)
$f_{yh}$	Transverse reinforcement expected yield stress (ksi)
$f'_{ce}$	Expected maximum concrete compressive strength (ksi)

### 8.7.4 Conventional Bent Cap-Column Joints

Conventional SCDOT substructures are not monolithic with the superstructure. They consist of columns and/or piles that frame into a bent cap or footing, and where girders are supported by bearings, or hinged-diaphragm connections.

If the principal tension requirement of Section 8.7.3 is not met, vertical and horizontal joint reinforcement in conformance with Sections 8.7.5 through 8.7.7 is required.

### 8.7.5 Vertical Reinforcement

On each side of a column subject to bending, the bent cap shall have vertical stirrups meeting the area requirement of Equation 8-27. The vertical stirrups should be located within a distance of  $0.5D_c$  from the column face as shown in Figure 8.6.

$$A_s^{jv} \geq 0.18A_{st} \quad (8-27)$$

Where:

$A_s^{jv}$	Area of vertical joint shear reinforcement (in <sup>2</sup> )
$A_{st}$	Total area of longitudinal reinforcement in the column/shaft (in <sup>2</sup> )

Longitudinal reinforcement contributing to bent cap flexural strength shall be clamped inside joint or effective joint with vertical ties. The total area of vertical ties shall meet the requirement of Equation 8-28.

$$A_s^{ji} \geq 0.09A_{st} \quad (8-28)$$

Where:

$A_s^{ji}$	Vertical beam stirrup reinforcement (in <sup>2</sup> )
$A_{st}$	Total area of longitudinal reinforcement in the column/shaft (in <sup>2</sup> )

These stirrups shall be hooked around the top and bottom layers of longitudinal reinforcement in the bent cap. The spacing of the stirrups should not exceed 18". See Figures 8.6 and 8.7 for additional information on stirrup placement.

### 8.7.6 Additional Cap Longitudinal Reinforcement

Additional longitudinal reinforcement in the bottom of the bent cap extending through the joint is required in addition to the total amount required for flexural strength. The additional steel must satisfy Equation 8-29.

$$A_s^{jf} = 0.09A_{st} \quad (8-29)$$

Where:

$A_s^{jf}$	Additional longitudinal reinforcement (in <sup>2</sup> )
$A_{st}$	Total area of column reinforcement in the column/shaft (in <sup>2</sup> )

This reinforcement shall extend a sufficient distance to develop its yield strength at a distance of  $0.5D_c$  from the column face, as shown in Figure 8.6.

Additional horizontal reinforcement shall be placed on the side faces of the bent cap with a total area meeting the requirement of Equation 8-30. This reinforcement can also be used to meet the temperature and shrinkage reinforcement and skin friction requirements of the AASHTO LRFD Specifications.

$$A_s^{sf} = 0.1 \max(A_s^{top}, A_s^{bot}) \quad (8-30)$$

Where:

$A_s^{sf}$  Area of longitudinal side face reinforcement in the bent cap (in<sup>2</sup>)

$A_s^{top}$  Area of flexural reinforcement in the top layer of the bent cap (in<sup>2</sup>)

$A_s^{bot}$  Area of flexural reinforcement in the bottom layer of the bent cap (in<sup>2</sup>)

### 8.7.7 Hoop Transverse Confinement Reinforcement

The volumetric ratio of column joint hoop reinforcement to be carried into the cap or footing shall meet the requirement of Equation 8-31.

$$\rho_s \geq \frac{0.4 A_{st}}{l_{ac}^2} \quad (8-31)$$

Where:

$\rho_s$  Volumetric ratio of transverse reinforcement (dimensionless)

$A_{st}$  Total area of longitudinal reinforcement in the column/shaft (in<sup>2</sup>)

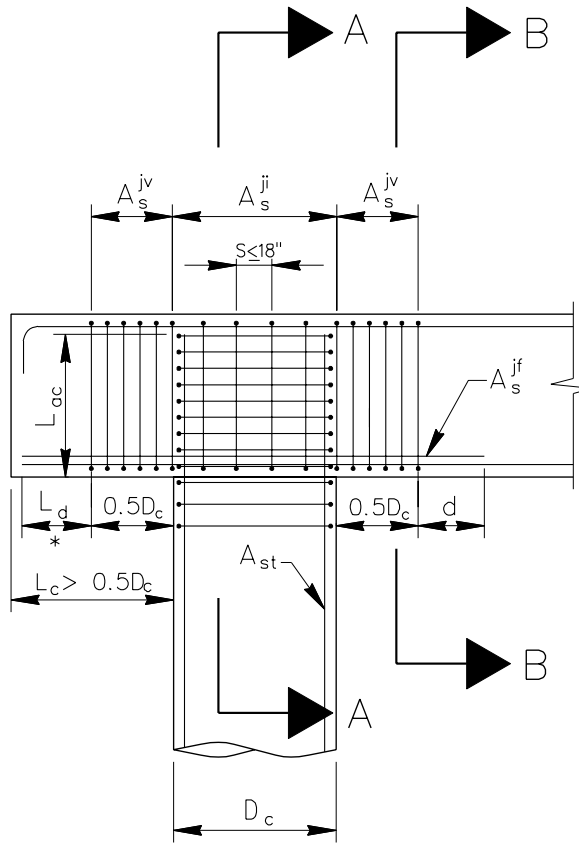
$l_{ac}$  Required anchorage length for longitudinal column reinforcement (in)

### 8.7.8 Knee Joints

The exterior joints of a bent cap shall be designated a "Knee Joint" when the length of the overhang as measured from the face of the column to the end of the cap is less than one-half the column diameter. Knee joints shall be detailed as follows.

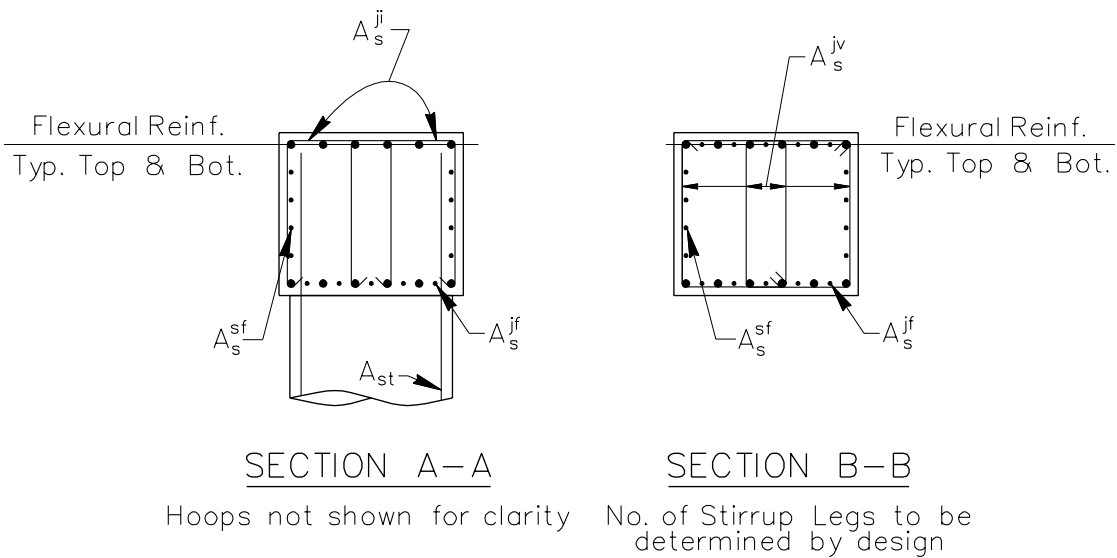
The cap flexural reinforcement shall be continuous. The only allowed splice type is through the use of ultimate mechanical couplers. The additional longitudinal reinforcement,  $A_s^{jf}$ , shall be developed through the use of 90° hooks at the end of the cap (see Figure 8.7).

The area of continuous cap flexural reinforcement can be considered in meeting the requirements of Section 8.7.5 for  $A_s^{fv}$  in the cap overhang region ( $L_c$ ) only.

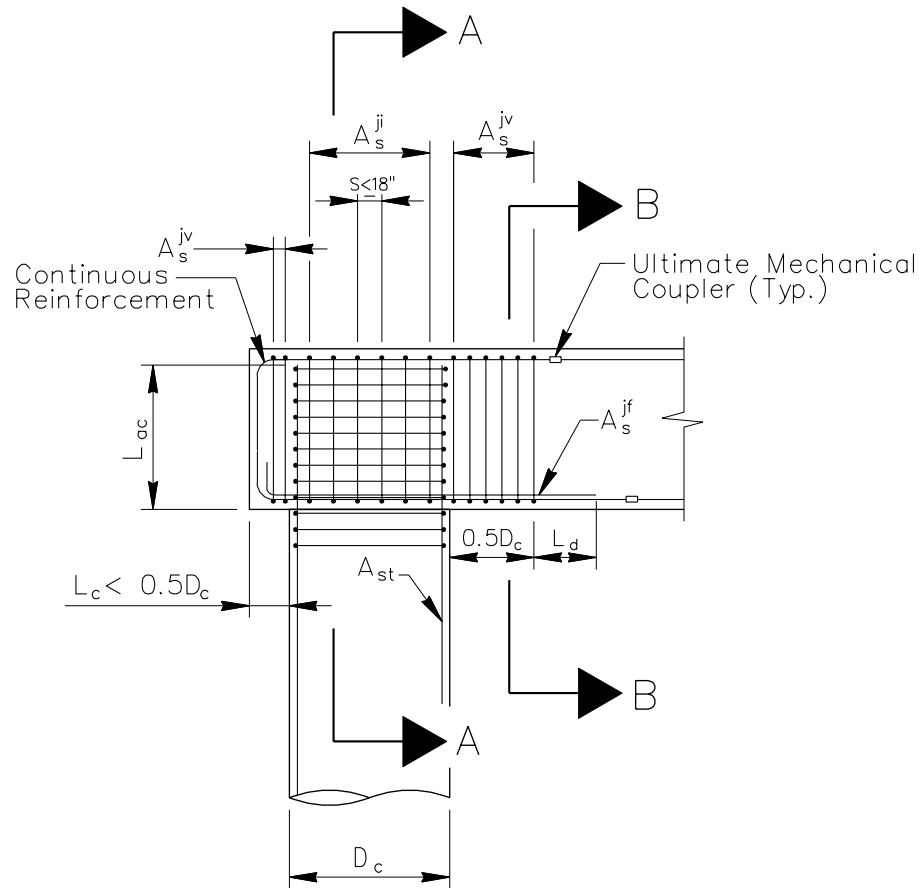


Note: Stirrups not required for joint shear are omitted for clarity.  
 Some column bars not shown for clarity.  
 \*Full development length of additional beam steel not required in cantilever.

ELEVATION

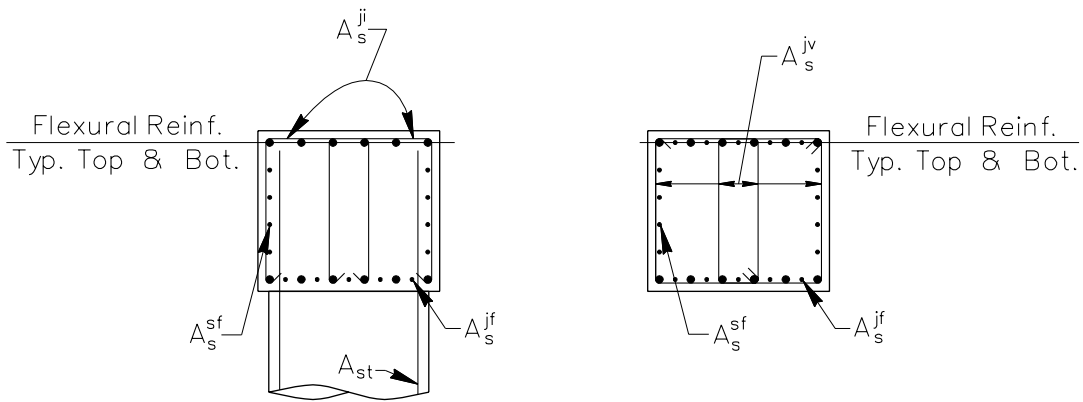


**Figure 8.6 Conventional Bent Cap to Column Joint Shear Reinforcement ( $L_c > 0.5D_c$ )**



Note: Stirrups not required for joint shear are omitted for clarity. Some column bars not shown for clarity.

ELEVATION



SECTION A-A

SECTION B-B

Hoops not shown for clarity No. of Stirrup Legs to be determined by design

**Figure 8.7 Conventional Bent Cap to Column Joint Shear Reinforcement ( $L_c < 0.5D_c$ )**

## 8.8 FOOTING JOINT SHEAR DESIGN

### 8.8.1 Footing-Column Joints

Column-footing joints are the same as inverted column-bent cap joints with greater effective width, calculated assuming a 45-degree spread from the column boundaries. The effective joint width is computed using Equation 8-18 or 8-19 depending on the shape of the column framing into the footing.

Principal compression stress shall not exceed the limit specified in Section 8.7.2. If the principal tension stress does not exceed the limit from Equation 8-25, then the minimum reinforcement specified by Equation 8-26 is required.

If the principal tension stress exceeds the limit of Equation 8-25, then the provisions of Section 8.8.2 through 8.8.4 are to be met.

### 8.8.2 Vertical Reinforcement

Vertical joint reinforcement is required extending from the face of the column to a distance  $0.5 D_c$  with a total area defined by Equation 8-32, as illustrated in Figure 8.8. Reinforcement bars making up this vertical joint reinforcement ( $A_s^{jv}$  see Figure 8.9) shall be no larger than #5 to allow for the top hook to be field bent from horizontal to the configuration shown in Figure 8.9.

$$A_s^{jv} \geq 0.72 A_{st} \quad (8-32)$$

Where:

- $A_s^{jv}$  Area of vertical joint shear reinforcement (in<sup>2</sup>)
- $A_{st}$  Total area of longitudinal reinforcement in the column/shaft (in<sup>2</sup>)

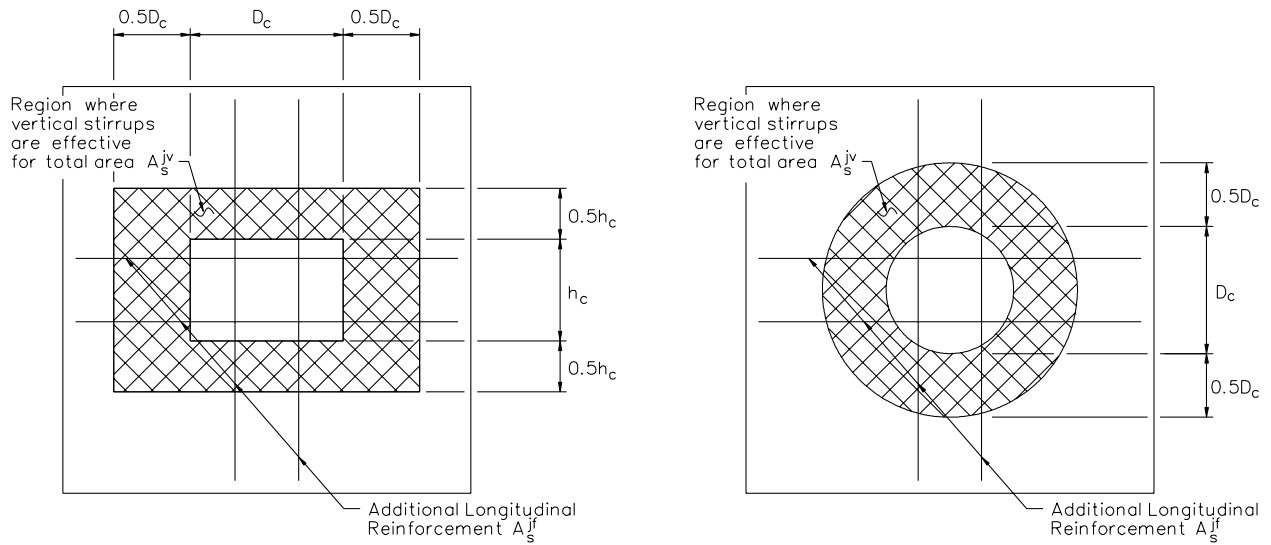
### 8.8.3 Horizontal Reinforcement

Additional longitudinal reinforcement in the footing of the total amount defined in Equation 8-29 over that required for flexural strength is required in the top of the footing extending through the joint and for a sufficient distance to develop its yield strength at a distance of  $0.5D_c$  from the column face, as shown in Figure 8.9. Since the column to footing connection resists moments from seismic forces acting both parallel and transverse to the longitudinal axis of the bridge, the additional reinforcement is required in both directions. Reinforcement may be hooked if straight bar development length is unattainable.

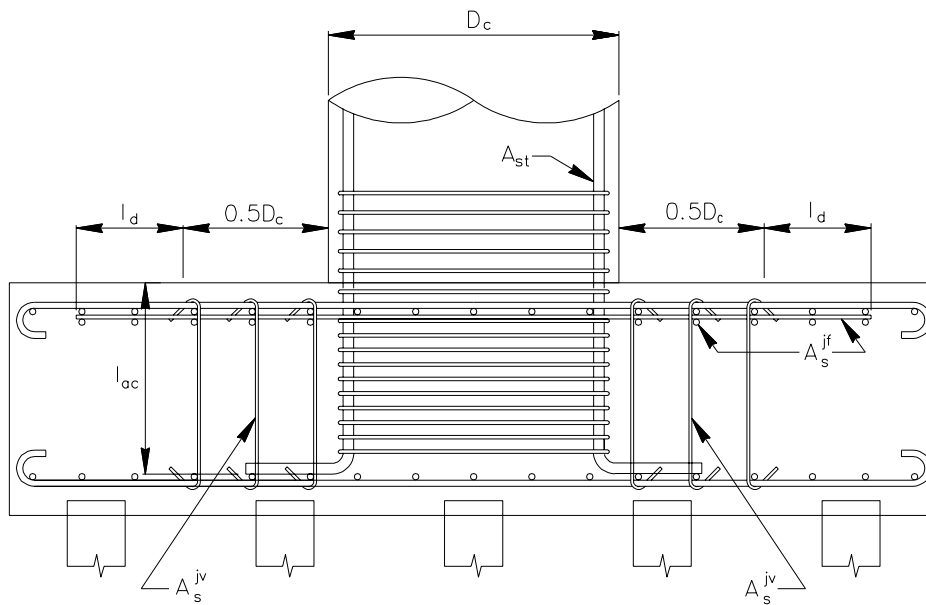
### 8.8.4 Hoop Transverse Confinement Reinforcement

The volumetric ratio of column joint hoop reinforcement to be carried into the footing shall not be less than the amount defined in Equation 8-31.





**Figure 8.8 Vertical Joint Shear Reinforcement Location**



Note: Stirrups not required for joint shear are omitted for clarity.

**Figure 8.9 Footing Joint Shear Reinforcement**

## 8.9 INTEGRAL BENT CAP JOINT SHEAR

### 8.9.1 Integral Superstructure-Column Joints

Bent caps are considered integral if they terminate at the outside of the exterior girder and respond monolithically with the girder system during dynamic excitation. The beam-column connection shall be designed to resist moments from seismic forces acting perpendicular to the centerline of bent. Moment resisting connections between the superstructure and the column shall be designed to transmit the maximum forces produced when the column has reached its overstrength capacity  $M_{po}$  including the effects of overstrength shear  $V_{po}$ .

General equilibrium equations and force-transfer mechanisms governing longitudinal response of integral superstructure connections are essentially the same as conventional bent cap column joints.

### 8.9.2 Integral Superstructure Joint Proportioning

Side cover of the bent cap shall be sufficient to place the required vertical reinforcement and not less than 12 inch, as shown in Figures 8.10 and 8.11.

Integral superstructure joints are the same as conventional column-bent cap joints with greater effective width, which is calculated assuming a 45-degree spread from the column boundaries using Equations 8-18 or 8-19.

Principal stresses shall not exceed the limits specified in Section 8.7.2. If the principal tension stress does not exceed the limit established by Equation 8-25, the minimum reinforcement specified by Equation 8-26 is required.

If the principal tension stress exceeds the limit from Equation 8-25, reinforcement is required based on requirements in Sections 8.9.3 through 8.9.6.

### 8.9.3 Vertical Reinforcement

For longitudinal seismic displacement, vertical joint reinforcement in the amount required by Equation 8-27 shall be placed in the side cover on both sides of the column. These stirrups shall be placed over a width not to exceed  $D_c$  measured from each side of the centerline of the column (total width of  $2D_c$ ).

For transverse seismic displacement of multiple column bents, vertical reinforcement satisfying Equation 8-27 is required on both sides of the column, placed in the same manner as conventional

bent caps. As shown in Figure 8.10, the regions of vertical shear reinforcement for longitudinal and transverse response overlap. Stirrup legs falling in the overlap regions shall be counted for both longitudinal and transverse response.

Longitudinal reinforcement contributing to bent cap flexural strength shall be clamped inside the joint with vertical ties. The total area of vertical ties shall meet the requirement of Equation 8-28.

### 8.9.4 Additional Flexural Reinforcement

Additional longitudinal reinforcement in the bottom of the bent cap extending through the joint is required in addition to the total amount required for flexure as calculated using Equation 8-29. This reinforcement shall extend a sufficient distance to develop its yield strength at a distance of  $0.5D_c$  from the column face.

Additional horizontal reinforcement shall also be placed on the sides of the bent cap with a total area meeting the requirement of Equation 8-30.

### 8.9.5 Horizontal Reinforcement

Horizontal stirrups or ties, with a total area given by Equation 8-33, shall be placed transversely around the vertical stirrups or ties in two or more layers spaced vertically at no more than 18 in. This reinforcement shall be placed within a distance  $D_c$  from the centerline of the column.

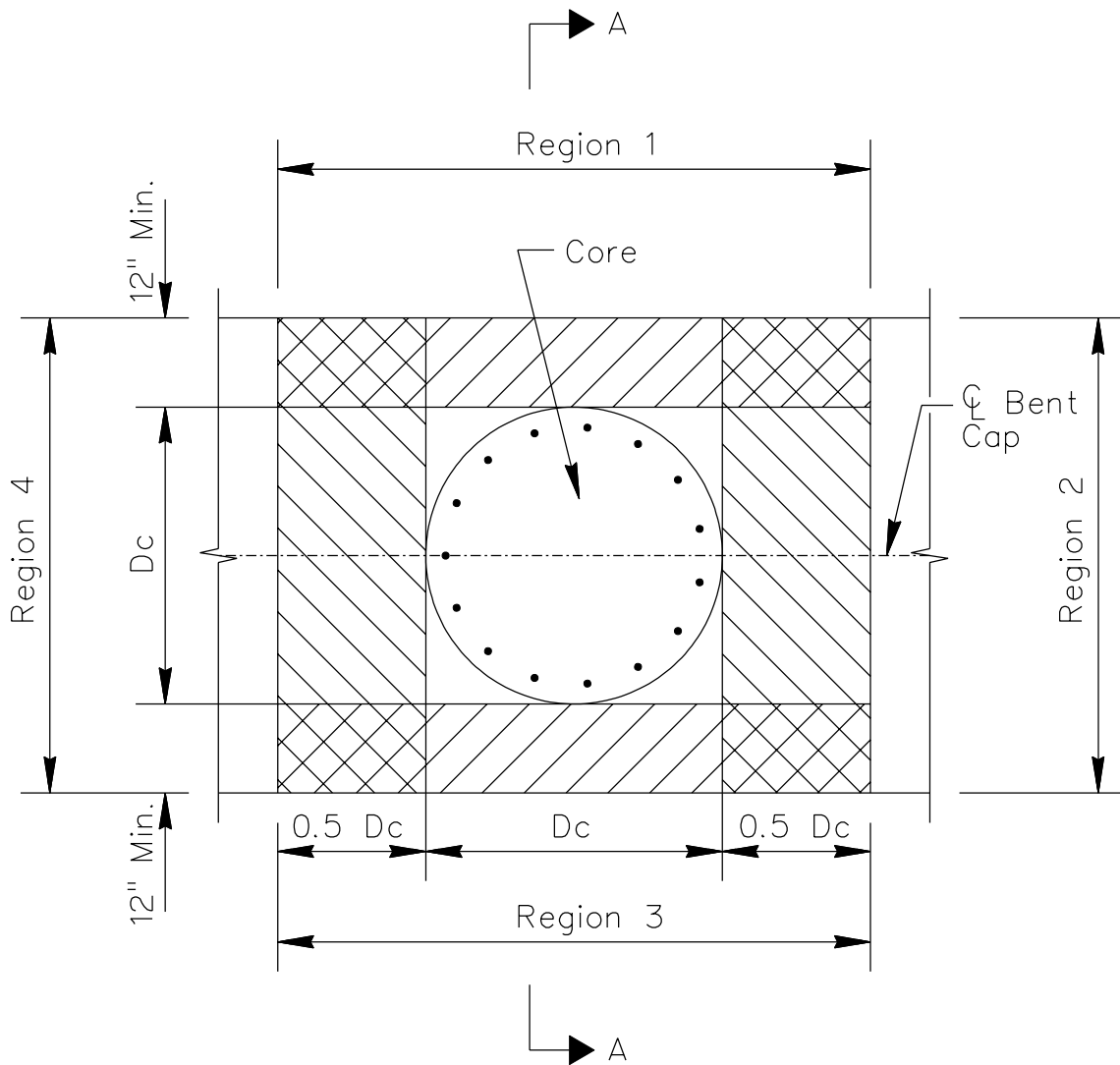
$$A_s^{jh} = 0.1A_{st} \quad (8-33)$$

Where:

$A_s^{jh}$  Area of horizontal stirrups (in<sup>2</sup>)  
 $A_{st}$  Total area of longitudinal reinforcement in the column/shaft (in<sup>2</sup>)

### 8.9.6 Hoop Transverse Confinement Reinforcement

The volumetric ratio of column joint hoop reinforcement to be carried into the bent cap shall not be less than the amount defined in Equation 8-31.

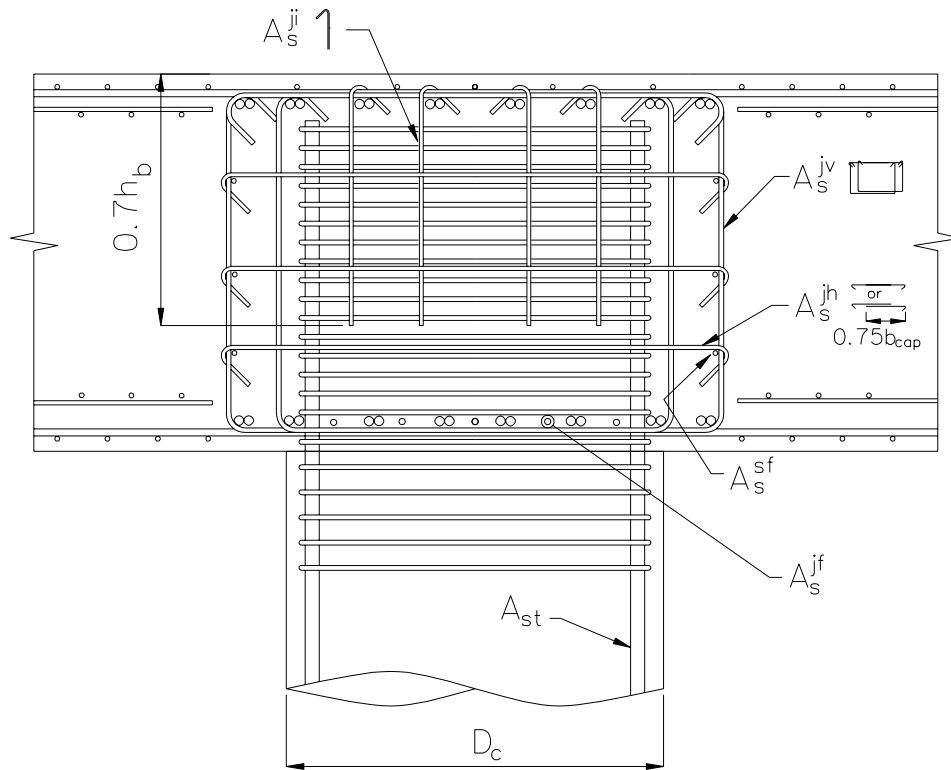


$A_s^j$  required in each region

Reinforcement in Overlapping Regions  
Apply to Both Regions

$0.5 A_s^j$  shall be placed within the core.  
See Section A-A in Figure 8-11.

**Figure 8.10 Integral Column to Superstructure Joint Shear Reinforcement - Plan**



SECTION A-A

Figure 8.11 Integral Column to Superstructure Joint Shear Reinforcement – Section A-A

## **Section 9**

# **MISCELLANEOUS DETAILING**

**SCDOT Seismic Design Specifications for Highway Bridges**



**TABLE OF CONTENTS**

**SECTION 9 – MISCELLANEOUS DETAILING.....9-1**

9.1 MINIMUM SUPPORT LENGTH..... 9-1

    9.1.1 SDC A and Single Span Bridges ..... 9-1

    9.1.2 SDC B and C Bridges ..... 9-1

    9.1.3 SDC D Bridges ..... 9-1

9.2 LONGITUDINAL AND TRANSVERSE CONNECTION ..... 9-1

    9.2.1 Anchor Bolt Design ..... 9-2

    9.2.2 Concrete Superstructure Shear Key Design..... 9-2

    9.2.3 Steel Superstructure Shear Key Design ..... 9-2

    9.2.4 Integral Backwall Design..... 9-2

9.3 END BENT FUSE DETAILING..... 9-3

    9.3.1 Transverse Direction (in the direction of centerline of end bent cap)..... 9-4

    9.3.2 Longitudinal Direction (in the direction of centerline of the bridge)..... 9-4

9.4 OTHER DETAILS AND REQUIREMENTS ..... 9-4

    9.4.1 Prestressed Concrete Beam End Diaphragms at Expansion Joints..... 9-4

    9.4.2 Prestressed Concrete Beam Closure Diaphragms ..... 9-4

    9.4.3 Retainer Blocks..... 9-5

    9.4.4 HP Pile Details..... 9-5

    9.4.5 Column Flares..... 9-5

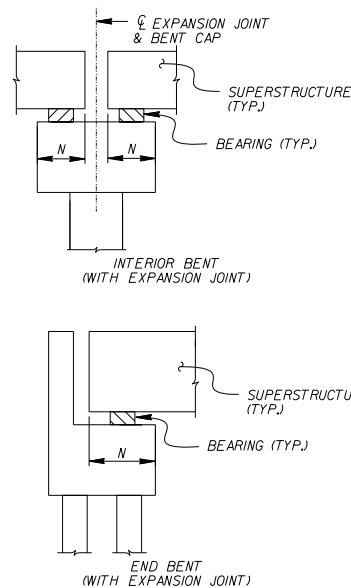




## SECTION 9 – MISCELLANEOUS DETAILING

### 9.1 MINIMUM SUPPORT LENGTH

The minimum support length at expansion bents and free standing or non-integral end bents shall accommodate the differential seismic displacements between the substructure and the superstructure. The minimum support length capacity shall meet or exceed the minimum support length demand of the superstructure. Support length at fixed bents (superstructure continuous over the bents) need not be computed. The minimum support length (see Figure 9.1) is computed using Equation 9-1 or 9-2.



**Figure 9.1 Dimensions for Support Length Requirement**

#### 9.1.1 SDC A and Single Span Bridges

$$N = \left(4 + \Delta_{ot} + 0.2H_s\right) \left(1 + \frac{S^2}{4000}\right) \geq 12'' \quad (9-1)$$

Where:

- $N$  Minimum support length (in)
- $\Delta_{ot}$  Movement attributed to prestress shortening creep, shrinkage and thermal expansion or contraction to be considered no less than one inch per 100 feet of bridge superstructure length between expansion joints (in)
- $H_s$  The largest column height in the most flexible frame adjacent to the expansion joint under consideration. The average height from the top of column to top of footing for pile bents, or to the point of fixity of drilled shaft or pile foundations. For single spans seated on abutments, the term is taken as the abutment height (ft)
- $S$  The skew angle of the bridge substructure measured from a line normal to the span (degrees)

#### 9.1.2 SDC B and C Bridges

$$N = \left(4 + \Delta_{ot} + 1.65\Delta_{eq}\right) \left(1 + \frac{S^2}{4000}\right) \geq 14'' \quad (9-2)$$

Where:

- $N$  Minimum support length (in)
- $\Delta_{eq}$  Seismic displacement demand of the long period frame on one side of the expansion joint (in)
- $\Delta_{ot}$  Movement attributed to prestress shortening creep, shrinkage and thermal expansion or contraction to be considered no less than one inch per 100 feet of bridge superstructure length between expansion joints (in)

#### 9.1.3 SDC D Bridges

The minimum support length for SDC D bridges shall satisfy Equation 9-2 except the lower boundary is 24".

### 9.2 LONGITUDINAL AND TRANSVERSE CONNECTIONS

Transverse seismic forces are transmitted to the substructure through dowel bars, anchor bolts and/or shear keys. Typically, these components are designed to behave elastically so that the combination of anchor bolts, dowel bars and/or shear keys are designed to satisfy Equation 9-3 in both the longitudinal and transverse directions for bridges of any SDC.

$$V_u \leq \phi_v (V_{sk} + V_{ab} + V_{bw}) \quad (9-3)$$

Where:

- $V_u$  Smaller of elastic shear force or the overstrength plastic hinge shear force (k)
- $V_{sk}$  Shear strength of the shear key (k)
- $V_{ab}$  Shear strength of anchor bolts (k)
- $V_{bw}$  Shear strength of the backwall (k)
- $\phi_v$  Shear strength reduction factor (dimensionless)

Bent cap anchor bolts and shear keys shall be capable of transferring the lateral resistance of the supporting bent or pier assuming a full plastic-hinge mechanism at overstrength. In this case, the strength reduction factor should be  $\phi_v = 0.85$ .

For bents consisting of short pier-walls it may not be feasible or desirable to develop the full lateral strength. If the shear key is designed to fuse, sufficient overhang shall be provided. In this case, the strength reduction factor should be  $\phi = 1.0$ . The capacity of shear keys should not exceed the shear capacity of the piles.

Shear keys, anchor bolts and dowel bars at end bent locations can be designed to fuse.

### 9.2.1 Anchor Bolt Design

Sufficient reinforcement shall be provided around the anchor bolts to develop the horizontal force. Potential concrete shear crack surfaces next to the anchorage shall have sufficient shear friction capacity to prevent failure.

The anchor bolt transverse capacity is computed using Equation 9-4 (assuming no threads are present in the shear plane).

$$V_{ab} = 0.48 A_b F_{ub} N_{ab} \quad (9-4)$$

Where:

- $V_{ab}$  Shear strength of anchor bolts (k)
- $A_b$  Cross sectional area of anchor bolt (in<sup>2</sup>)
- $F_{ub}$  Specified minimum tensile strength of the anchor bolt (ksi)
- $N_{ab}$  Number of anchor bolts (dimensionless)

### 9.2.2 Concrete Superstructure Shear Key Design

Shear keys shall be designed to restrain the relative transverse displacement between the superstructure and substructure. Shear keys are typically constructed monolithically with bent caps. Shear keys at skewed expansion joints shall be designed to allow movement parallel to the centerline of the bridge only. A typical concrete shear key is shown in Figure 9.2. The shear strength of the shear key is computed using Equation 9-5.

$$V_{sk} = 1.4 A_s^{sk} f_y \quad (9-5)$$

Where:

- $V_{sk}$  Shear strength of the shear key (k)

- $A_s^{sk}$  Area of reinforcement crossing the shear plane (in<sup>2</sup>)
- $f_y$  Specified minimum yield strength of reinforcement steel (ksi)

The shear strength of the key is limited by the criteria of Equations 9-6 and 9-7.

$$V_{sk} \leq 0.2 f'_c A_{cv} \quad (9-6)$$

$$V_{sk} \leq 0.8 A_{cv} \quad (9-7)$$

Where:

- $V_{sk}$  Shear strength of the shear key (k)
- $f'_c$  Specified concrete compressive strength (ksi)
- $A_{cv}$  Area of concrete in the shear plane (in<sup>2</sup>)

Shear keys shall be proportioned so that the height of the shear key, or distance to top of load application shall not exceed 0.3 times the length of the shear key parallel to the centerline of bridge. Expansion joint filler can be used to reduce the height of this contact region, where compressible joint material is used above.

### 9.2.3 Steel Superstructure Shear Key Design

Shear keys for steel superstructures shall be detailed as shown in Figure 9.3. Care should be taken to allow a gap between the shear key and the bottom flange of the girder in the range of 1/4" to 1/2" to allow construction tolerance and the anchor bolts of the girder bearings to become engaged during seismic displacement.

The shear keys should be placed so the flange of the rolled shape is parallel to the bottom flange of the girder. The shear keys are to be placed in pairs, one on each side of the girder, symmetrical about the centerline of the girder.

The capacity of the steel shear key is limited by either the shear capacity of the rolled shape or the anchor bolts attaching it to the cap.

### 9.2.4 Integral Backwall Design

For integral end bents, the lateral seismic forces are transmitted to the piles in part by the reinforcement connecting the superstructure to the end bent cap. This integral backwall shall be designed in conjunction with the shear keys and anchor bolts to satisfy the condition of Equation 9-3.

The integral backwall strength is evaluated using Equation 9-8.

$$V_{bw} = 0.15A_{cv} + 1.4A_s^{bw} f_y \quad (9-8)$$

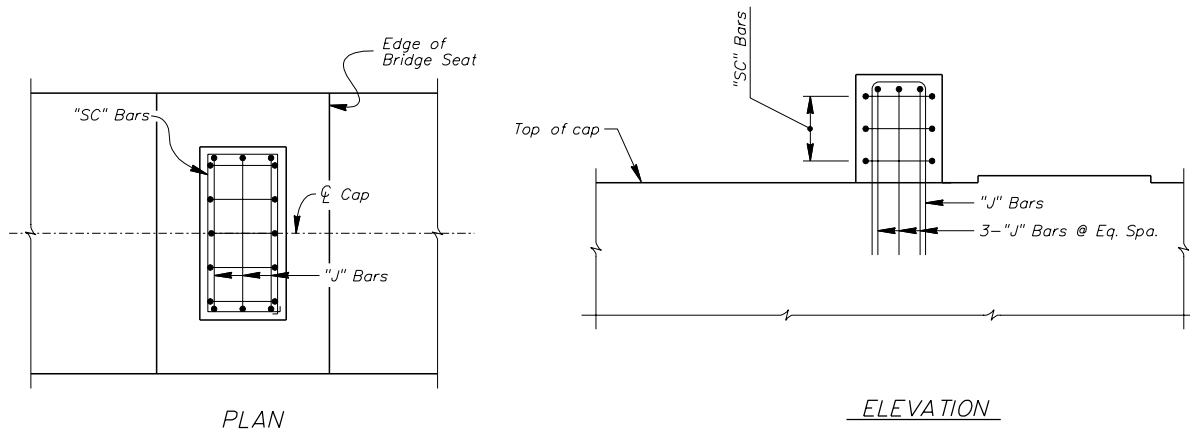
Where:

- $V_{bw}$  Shear strength of the backwall (k)
- $A_{cv}$  Area of concrete in the shear plane (in<sup>2</sup>)
- $A_s^{bw}$  Area of steel in the backwall crossing the shear plane (in<sup>2</sup>)
- $f_y$  Specified minimum yield strength of reinforcement steel (ksi)

designed to fail before the loads become more than the end bent piles can sustain before attaining plastic damage. This prevents damage to the piles below ground, and makes any seismic damage easier to identify. A fuse is not permitted in SDC A bridges.

### 9.3 END BENT FUSE DETAILING

The use of a fusible connection is to prevent damage to the substructure components of the end bent. Where other superstructure to substructure connections have been designed to remain elastic while transmitting the seismic displacement and forces to the substructure, this connection will be



Shear keys are cast monolithic with bent caps

### SHEAR KEY DETAILS

Figure 9.2 Concrete Superstructure Shear Key

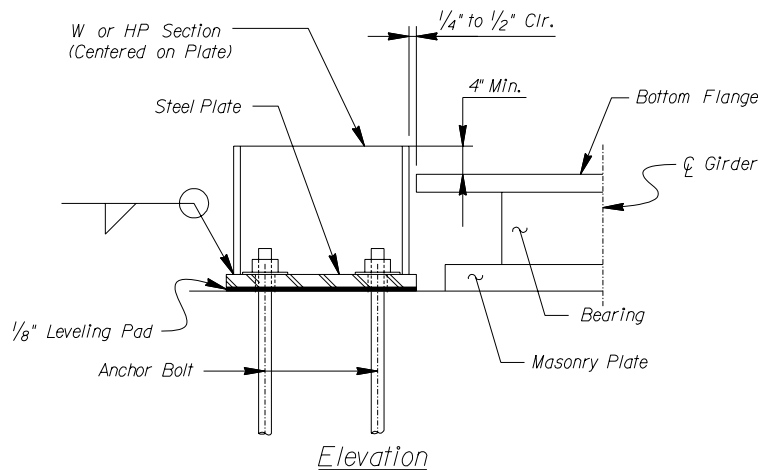


Figure 9.3 Steel Superstructure Shear Key

### 9.3.1 Transverse Direction (in the direction of centerline of end bent cap)

The shear keys in conjunction with the anchor bolts shall be designed to fuse in order to absorb seismic energy associated with movement in the transverse direction. The shear keys and anchor bolts shall be designed to meet the requirements of Equation 9-9.

$$0.75V_p > (2V_{sk} + V_{ab} + V_{bw}) \geq 0.5V_p \quad (9-9)$$

Where:

- $V_p$  Plastic hinge shear force (k)
- $V_{sk}$  Shear strength of the shear key (k)
- $V_{ab}$  Shear strength of anchor bolts (k)
- $V_{bw}$  Shear strength of the backwall (k)

### 9.3.2 Longitudinal Direction (in the direction of centerline of the bridge)

The anchor bolts and backwall reinforcement / dowels shall be designed to fuse in order to absorb seismic energy associated with movement in the longitudinal direction. The anchor bolts and the connection between the end bent backwall and the end bent cap shall be designed and detailed to meet the requirements of Equation 9-10.

$$0.75V_p > (V_{bw} + V_{ab}) \geq 0.5V_p \quad (9-10)$$

Where:

- $V_p$  Plastic hinge shear force (k)
- $V_{bw}$  Shear strength of the backwall (k)
- $V_{ab}$  Shear strength of anchor bolts (k)

The strength of the backwall to end bent cap connection should be analyzed using Equation 9-11 as follows:

$$V_{bw} = 0.15A_{cv} + 1.4A_s^{bw} f_{ye} \quad (9-11)$$

Where:

- $V_{bw}$  Shear strength of the backwall (k)
- $f_{ye}$  Expected yield strength of reinforcement steel (ksi)
- $A_{cv}$  Area of concrete in the shear plane (in<sup>2</sup>)
- $A_s^{bw}$  Area of steel in the backwall crossing the shear plane (in<sup>2</sup>)

The designer should consider the possibility that the requirements of the strength and service load combinations of the AASHTO LRFD Specifications could control the reinforcing detailing of the end bent connection. This may require reinforcement that will

prevent the fuse from forming, especially with integral end bents. In this situation, the designer can either design the connection to remain elastic or consider another substructure configuration.

If the fuse is expected to form in the longitudinal direction, 1.2 times the minimum support length from Section 9.1 is required.

## 9.4 OTHER DETAILS AND REQUIREMENTS

### 9.4.1 Prestressed Concrete Beam End Diaphragms at Expansion Joints

Concrete diaphragms in prestressed concrete beam bridges transfer seismic forces from the center of mass of the superstructure to the bottom of the girder and the bent cap. For bearing-supported girders, shear keys bear on the end diaphragm, and sufficient reinforcement is required to resist equal and opposite shear key forces.

Hinged diaphragms provide direct bearing to the bent cap and also transfer shear from the superstructure. In this configuration, the hinged diaphragm must provide a sufficient gap to allow rotation along the axis of the bent. Further direct shear transfer through the use of dowels is used to transfer the seismic forces. In this configuration, the diaphragm shall have sufficient width and reinforcement to transfer shear based on the column-plastic hinging at overstrength.

Compressible material between ¼" and ½" in thickness shall be placed between the concrete diaphragm and the shear keys. This allows for the anchor bolts to be engaged in the shear force transfer of the superstructure to the substructure.

The design of the concrete diaphragm shall be done using a strut and tie model as directed in the AASHTO LRFD Specifications for SDC B to SDC D bridges. Sample reinforcement and details can be seen in Figure 9.4.

SDC A bridges are exempt from detailed seismic analysis and detailing of concrete end diaphragms.

### 9.4.2 Prestressed Concrete Beam Closure Diaphragms

The prestressed concrete beam closure diaphragms are placed at fixed bearing bents of continuous for live load superstructures. The inclusion of a shear key requires a minimal compressive material between the concrete diaphragm and the shear keys. The

compressible material shall be between ¼" and ½" in thickness. The design of the concrete diaphragm shall be done using a strut and tie model as directed in the AASHTO LRFD Specifications Article 5.6.3 for SDC B to SDC D bridges. Sample reinforcement and details can be seen in Figure 9.5.

SDC A bridges are exempt from seismic analysis and detailing of concrete closure diaphragms.

### 9.4.3 Retainer Blocks

Skewed expansion joints require special attention due to poor performance observed during recent seismic events. This is especially true for units that include the end bent, because significantly large resistance transverse to the longitudinal axis of the bridge can occur at this location even if the backwall is designed to fuse. This additional resistance causes significant torsion along with the overall bridge movements resulting in significant displacements at the other end of the unit, which may cause girders to become unseated. Shear keys, which are placed between girders, are proved to be effective to prevent girder unseating. In conjunction with shear keys, retainer blocks are suggested to prevent exterior girder unseating. Retainer block shall be considered as part of the shear keys to resist lateral seismic forces.

Retainer blocks are placed on both ends of an interior expansion bent, and both ends of non-integral end bents when the skew angle, as measured in Figure 9.6 exceeds 20 degrees. The retainer blocks are to be poured monolithically with the bent cap. The blocks are placed flush with the outside edge of the cap and parallel with the centerline of the girder on the inside face. The block is situated such that excessive movement in the transverse direction of the superstructure will engage contact between the block and the sole plate of the girder or beam.

The retainer blocks shall not be used for free standing end bents designed to fuse under the SEE event. The retainer blocks are also not to be used in the computation of transverse shear capacity for the transmission of the plastic hinge shear force.

The retainer blocks are detailed as shown in Figure 9-6. Reinforcement consists of "A" and "J" bars placed with a minimum of 2" clear cover. The inside face of the block shall be separated from the sole plate of the girder or beam by 1" of compressible material. The top of the block shall be set a minimum of 6" above the top of the sole plate. The block shall have a minimum width of 1'-0" in plan view and extend the full width of the bent cap.

### 9.4.4 HP Pile Details

All piles shall be adequately anchored to the pile cap. Anchoring devices shall be provided to develop all uplift forces but not less than 10 percent of the maximum axial pile capacity. A typical SCDOT pile anchorage detail (Figure 9.7) is recommended. However, additional reinforcing bars shall be provided per design. Equation 9-12 provides the method of computing the total required anchorage reinforcing bars.

$$A_s^{anchor} = \frac{P_u}{f_{ye} \cos(\theta)} \quad (9-12)$$

Where:

$A_s^{anchor}$  Area of concrete in the shear plane (in<sup>2</sup>)

$P_u$  Design uplift force (k)

$f_{ye}$  Expected yield strength of reinforcement steel (ksi)

$\theta$  Angle as shown in Figure 9.7

### 9.4.5 Column Flares

Column Flares that are integrally connected to the bent cap soffit should be avoided whenever possible. Lightly reinforced integral flares shall only be used when required for service load design or aesthetic considerations and are permitted for SDC A and B. The flare geometry shall be kept as slender as possible. Test results have shown that slender lightly reinforced flares perform adequately after cracking has developed in the flare concrete essentially separating the flare from the confined column core. However, integral flares require higher shear forces and moments to form the plastic hinge at the top of the column compared to isolated flares. The higher plastic hinging forces must be considered in the design of the column, superstructure and footing.

Column flares shall be nominally reinforced outside the confined column core to prevent the flare concrete from completely separating from the column at high ductility levels. The reinforcement ratio for the transverse reinforcement, outside of the column core, that confines the flared region shall be 0.45% for the upper third of the flare and 0.75% for the bottom two-thirds of the flare. The minimum longitudinal reinforcement within the flare shall be equivalent to #6 bars @ 18 inch spacing.

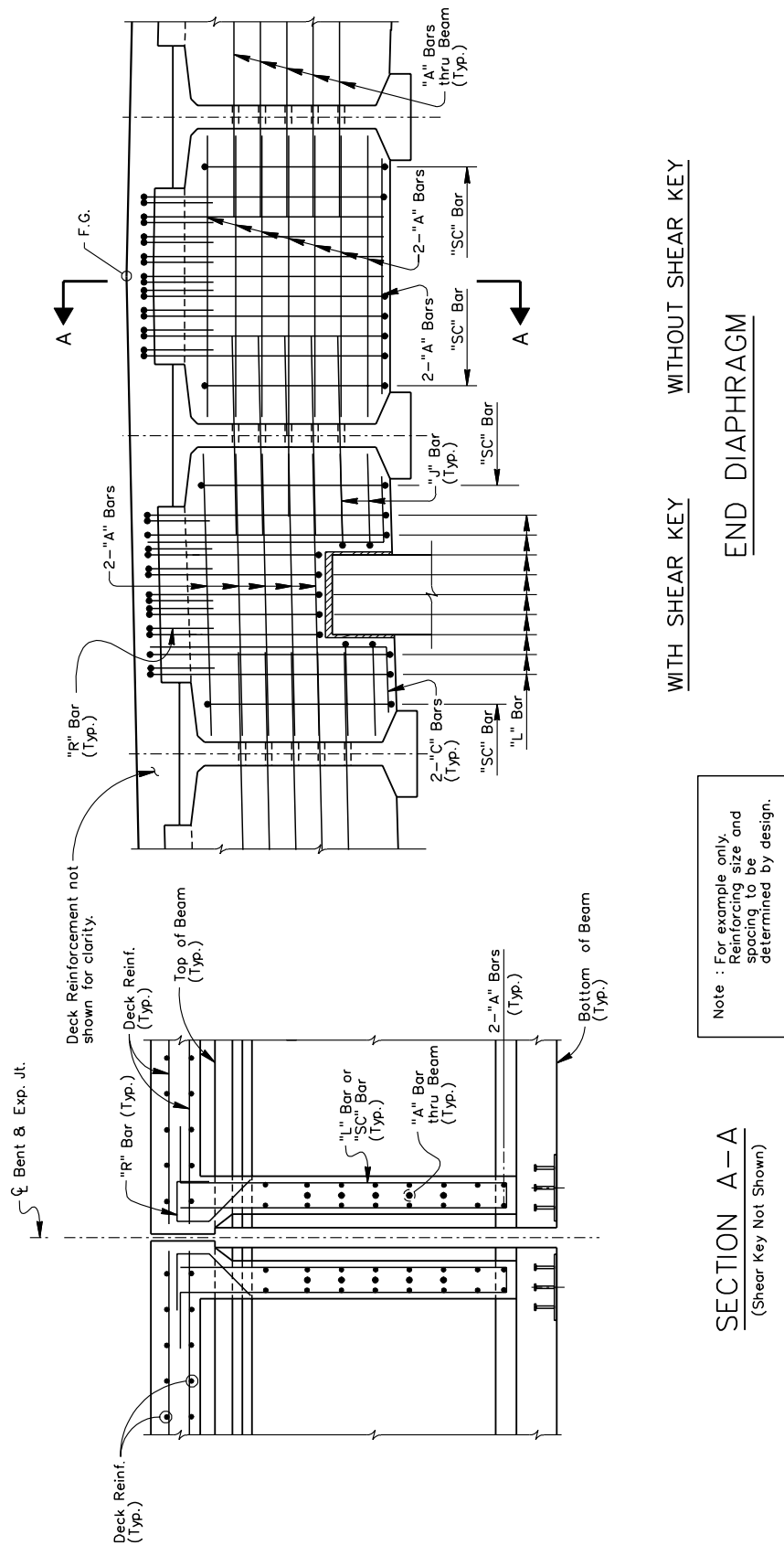


Figure 9.4 Example End Diaphragm

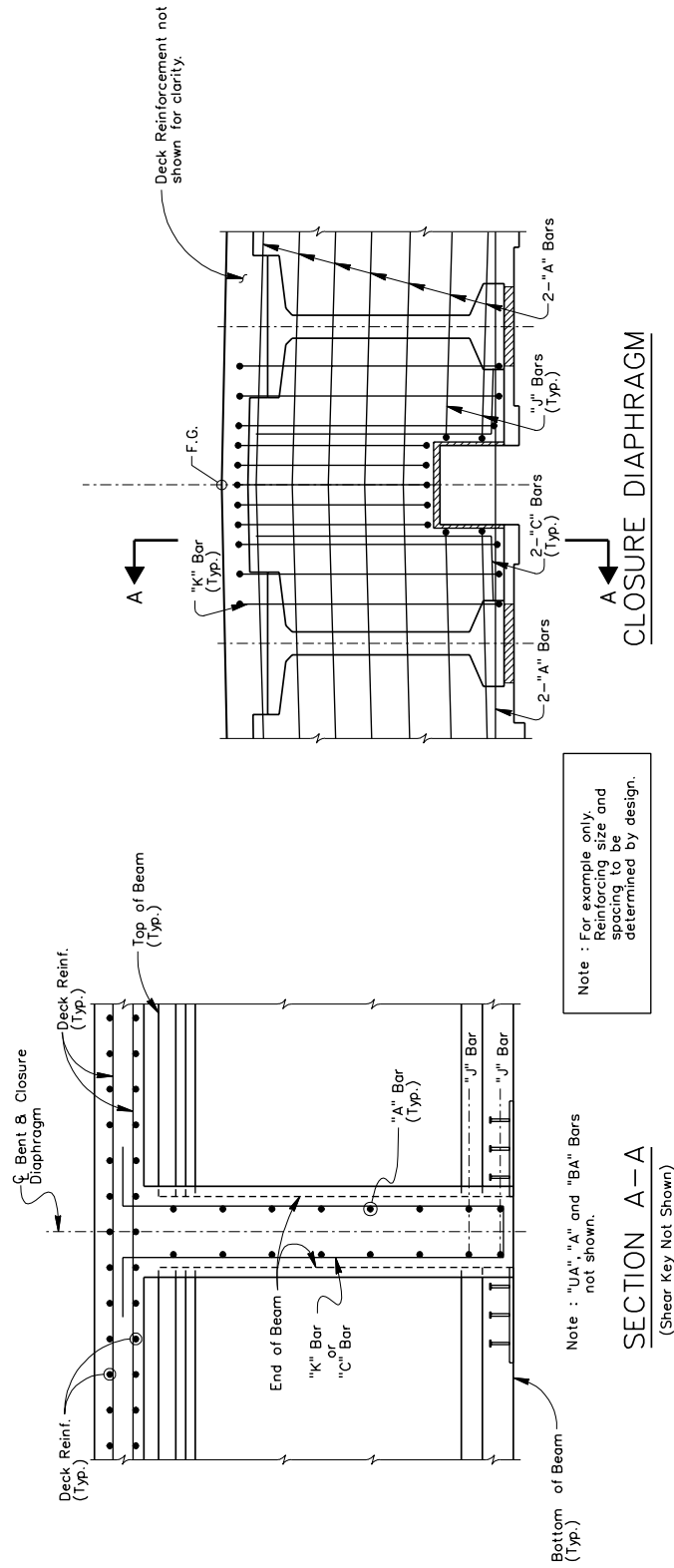
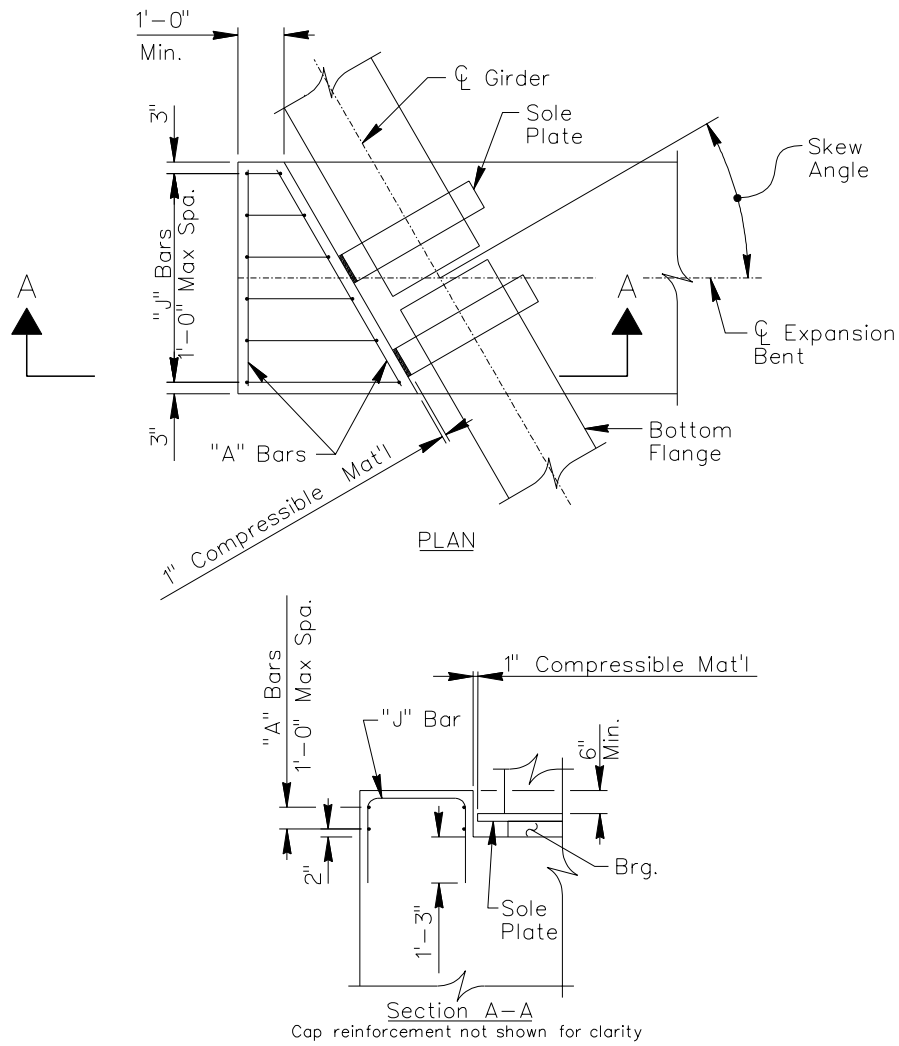
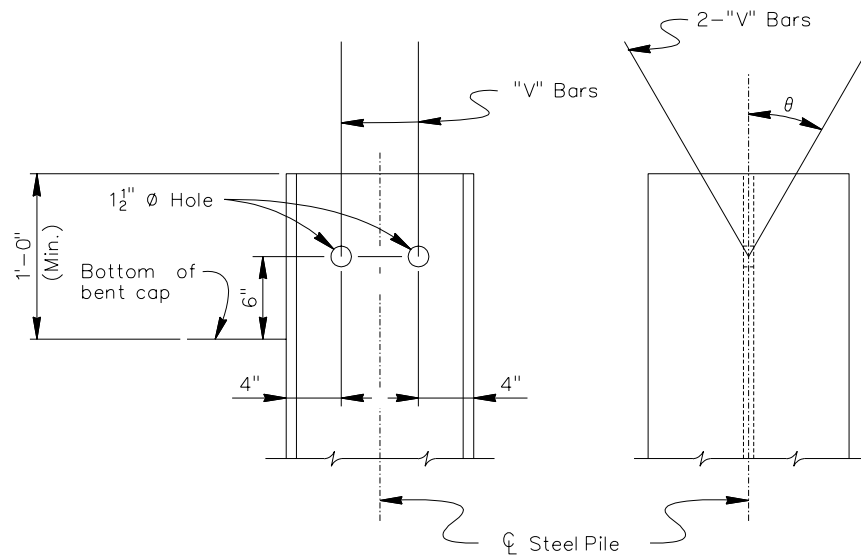


Figure 9.5 Example Closure Diaphragm



**Figure 9.6 Retainer Block Details**





Rebar shall be tied or wedged tightly against the top of the hole.

**Figure 9.7 Pile Anchorage Detail**