

CHAPTER 5
FIELD AND LABORATORY
TESTING PROCEDURES

GEOTECHNICAL DESIGN MANUAL

January 2022

Table of Contents

<u>Section</u>	<u>Page</u>
5.1 Introduction	5-1
5.2 Sampling Procedures	5-1
5.2.1 Soil Sampling	5-1
5.2.2 Rock Core Sampling	5-5
5.3 Field Testing Procedures	5-6
5.3.1 Test Pits	5-6
5.3.2 Soil Borings	5-6
5.3.3 Standard Penetration Test	5-8
5.3.4 Dynamic Cone Penetrometer Test	5-9
5.3.5 Cone Penetrometer Test	5-9
5.3.6 Dilatometer Test	5-10
5.3.7 Pressuremeter Test	5-11
5.3.8 Field Vane Shear Test	5-13
5.3.9 Double-Ring Infiltrometer Test	5-15
5.3.10 Geophysical Testing Methods	5-15
5.4 Soil/Rock Laboratory Testing	5-22
5.4.1 Grain-Size Analysis	5-22
5.4.2 Moisture Content	5-23
5.4.3 Atterberg Limits	5-23
5.4.4 Specific Gravity of Soils	5-24
5.4.5 Undisturbed Sample Preparation	5-24
5.4.6 Strength Tests	5-24
5.4.7 Consolidation Test	5-32
5.4.8 Organic Content	5-39
5.4.9 Shrinkage and Swell	5-39
5.4.10 Permeability	5-40
5.4.11 Compaction Tests	5-40
5.4.12 Relative Density Tests	5-41
5.4.13 Electro-Chemical Tests	5-41
5.4.14 Rock Cores	5-43
5.5 Quality Assurance/Quality Control	5-43
5.5.1 Field Testing QA/QC Plan	5-43
5.5.2 Laboratory Testing QA/QC Plan	5-44
5.6 References	5-44

List of Tables

<u>Table</u>	<u>Page</u>
Table 5-1, Expected Calibration Values	5-11
Table 5-2, Consolidation Parameters and Symbols.....	5-33
Table 5-3, Determination of Preconsolidation Stress.....	5-35

List of Figures

Figure	Page
Figure 5-1, Fixed-Piston Sampler.....	5-3
Figure 5-2, Floating Piston Sampler.....	5-4
Figure 5-3, Hydraulic Piston Sampler.....	5-5
Figure 5-4, Pressuremeter Curve.....	5-12
Figure 5-5, Field Vane Devices.....	5-14
Figure 5-6, SASW Shear Wave Velocity Testing.....	5-16
Figure 5-7, Downhole Seismic Testing.....	5-17
Figure 5-8, Crosshole Seismic Testing.....	5-18
Figure 5-9, Suspension Logging Schematic.....	5-19
Figure 5-10, Acoustic Televiwer Image.....	5-20
Figure 5-11, Seismic Refraction Testing.....	5-21
Figure 5-12, Data Reduction Example for Determining Depth to Hard Layer.....	5-21
Figure 5-13, Interpretation of UU Test Data.....	5-26
Figure 5-14, Interpretation of CU Test Data.....	5-27
Figure 5-15, Mohr Circle Depicting Mohr-Coulomb Failure Criterion.....	5-28
Figure 5-16, Stress Path (p' - q') Plot.....	5-29
Figure 5-17, Direct Shear Test Results.....	5-31
Figure 5-18, Void Ratio versus log Time.....	5-33
Figure 5-19, Normally Consolidated.....	5-35
Figure 5-20, Overconsolidated.....	5-35
Figure 5-21, Under Consolidated.....	5-36
Figure 5-22, Determination of Preconsolidation Stress from e -log p	5-36
Figure 5-23, Determination of Preconsolidation Stress from ϵ -log p	5-37
Figure 5-24, Change in Work vs. Vertical Effective Stress.....	5-38

CHAPTER 5

FIELD AND LABORATORY TESTING PROCEDURES

5.1 INTRODUCTION

This Chapter discusses items related to field and laboratory testing procedures. Sections 5.2 and 5.3 discuss sampling procedures and the different methods of retrieving soil and rock samples. These Sections also discuss drilling procedures and what types of equipment are typically available. Section 5.4 discusses soil/rock laboratory testing and the different types of testing procedures. Tests shall be performed in accordance with ASTM and/or AASHTO standards. Where applicable the appropriate SCDOT testing procedures shall be used. Any deviations from the accepted testing procedures (includes both field and laboratory) shall be made in writing to the OES/GDS prior to the testing for review and acceptance. As appropriate the RPG/GDS shall consult with either the OES/GDS or OMR. All tests shall be performed by a certified AASHTO re:source (formerly called AMRL) for the specific test being performed. As required, the GEC shall provide Excel[®] spreadsheets that contain data from various tests. In addition, the GEC shall contact the OES/GDS to ascertain the current version of Excel[®] being used by SCDOT.

5.2 SAMPLING PROCEDURES

5.2.1 Soil Sampling

ASTM and AASHTO have procedures that must be followed for the collection of field samples. All samples must be properly obtained, preserved, and transported to a laboratory facility in accordance with these procedures in order to preserve the samples as best as possible. There are several procedures that can be used for the collection of samples as described below. See ASTM D4220 - *Standard Practices for Preserving and Transporting Soil Samples*.

5.2.1.1 Bulk Samples

Bulk samples are highly disturbed samples obtained from auger cuttings or test pits. The quantity of the sample depends on the type of testing to be performed, but can range up to 50 lb. or more. Typical testing performed on bulk samples include moisture-density relationship, moisture-plasticity relationship, grain-size distribution, natural moisture content, and triaxial compression or direct shear testing on remodeled specimens.

5.2.1.2 Split-Barrel Sampling

The most commonly used method for obtaining samples is the split-barrel sampler, also known as the standard split-spoon sampler. The split-spoon has an interior length that ranges from 18 to 30 inches not including the length of the shoe, typically 1 to 2 inches. This sampler is used in conjunction with the Standard Penetration Test (SPT). The sampler is driven into soil by means of hammer blows. The number of blows required for driving the sampler through multiple 6-inch intervals is recorded. The 2nd and 3rd 6-inch intervals are added to make up the standard penetration number, N_{meas} . The split-spoon shall not be driven more than the interior length into the subsurface soils. After driving is completed the sampler is retrieved and the soil sample is

removed and placed into air tight containers. The entire retrieved sample shall be placed in the air tight container (i.e., plastic bag). For those split-spoons that encounter a change in soil type, each soil type will be placed in a separate air tight container to prevent combination of the samples. The SPT and collection of samples is to be done at 5-foot intervals, except in the upper 10 feet where samples will be collected every 2 feet. This type of sampling is adequate for natural moisture content, grain-size distribution, moisture-plasticity relationship (Atterberg Limit tests), and visual identification. See ASTM D1586 - *Standard Test Method for Standard Penetration Test (SPT) and Split-Barrel Sampling of Soils* (AASHTO T206 - *Standard Method of Test for Penetration Test and Split-Barrel Sampling of Soils*).

5.2.1.3 Undisturbed Sampling

The Shelby tube is a thin-walled steel tube pushed into the soil to be sampled by hydraulic pressure and spun to shear off the base. Shelby tube sampling is also known as undisturbed (UD) sampling. After the sampler is pulled out, the sampler is immediately sealed and taken to the laboratory facility. This process allows the sample to be undisturbed as much as possible and is suitable for fine-grained soils that require strength and consolidation tests. See ASTM D1587 – *Standard Practice for Thin-Walled Tube Sampling of Soils for Geotechnical Purposes* (AASHTO T207 – *Standard Method of Test for Thin-Walled Tube Sampling of Soils*). There are a variety of methods that may be used to collect Shelby tube samples. The following Sections provide a description of the most commonly used types of sampling methods. It is not the intention of this Manual that this list be comprehensive. Prior approval is required to use other sampling procedures, contact the OES/GDS and RPG/GDS for review and acceptance. A soil test boring log shall be prepared for all locations where UD samples are not collected within an existing soil test boring. The location (depth) of UD taken in an existing soil test boring shall be indicated on the soil test boring log. See Chapter 6 for the preparation and presentation of the UD soil test boring log.

5.2.1.3.1 Fixed Head or Shelby Sampler

The simplest means of obtaining a Shelby tube sample is through the use of a fixed head attachment that allows a Shelby tube to be connected to the drill string. The head contains a check valve that allows water and drilling mud to exit the head as the sampler is lowered to the bottom of the borehole and pushed into the soil using the drill rig. This sampling method is typically used for firm to stiff fine-grained soils that are not very susceptible to disturbance and are strong enough to stay in the tube during retrieval.

5.2.1.3.2 Fixed Piston Sampler

This sampler has the same standard dimensions as the Shelby sampler above, but with the addition of a piston that fits inside the tube (see Figure 5-1). The sampler is connected to the drilling rods and a small diameter activation rod extends through the drill string from the piston up to the ground surface. The piston is positioned at the bottom of the thin-wall tube while the sampler is lowered to the bottom of the hole, thus preventing disturbed materials from entering the tube. The piston is fixed in place on top of the soil to be sampled by locking the activation rods to a point of fixity on the ground surface (e.g., a sawhorse, the drill rig, etc.). A sample is obtained by pressing the tube into the soil with a continuous, steady thrust using the drill rig. The stationary piston is held fixed on top of the soil while the sampling tube is advanced. This reduces the stress on the soil during the sampling process and creates suction while the sampling tube is retrieved thus aiding in retention of the sample. This sampler is suitable for soft to firm clays and silts as

well as some clayey or silty sands. As compared to other thin-walled tube sampling methods, fixed piston sampling reduces disturbance and increases sample recovery. See ASTM D6519 – *Standard Practice for Sampling of Soil Using the Hydraulically Operated Stationary Piston Sampler*.

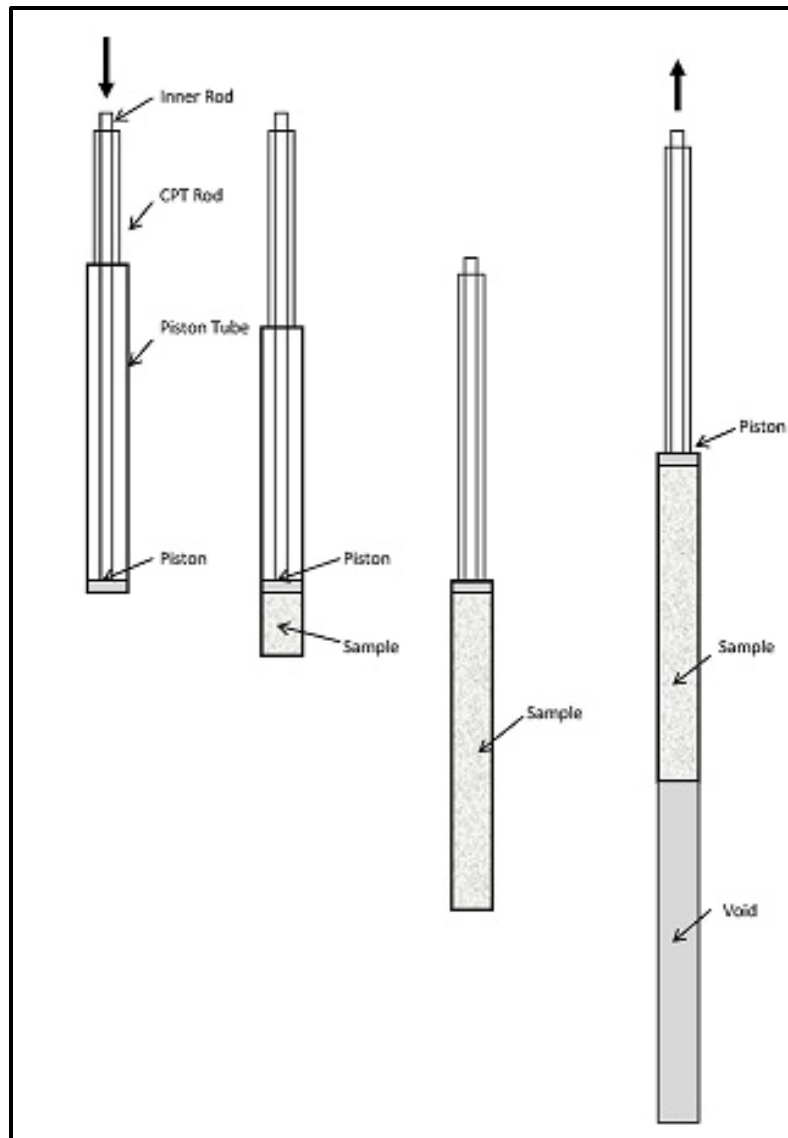

Figure 5-1, Fixed-Piston Sampler

(<https://www.probedrill.com.au/geotechnical-service/piston-sampling/> (2021))

5.2.1.3.3 Floating Piston Sampler

This sampler is similar to the fixed method above, except that activation rods are not used and the piston is not fully fixed (see Figure 5-2). A wedge mechanism limits piston movement to 1 direction, which is towards the top of the sampling tube. As with the fixed piston sampler, the piston is initially positioned at the bottom of the tube. As the tube is pushed into the soil, the piston rides on the top of the sample. Since the piston is not fixed in place and is free to move down as the tube is being pushed, it applies a load to the soil. If the soil is soft, the loading from the piston may create significant sample disturbance and may even exceed the soil shear strength. Therefore, this method should be limited to firm to stiff soils. When the tube is retrieved,

the wedge mechanism fixes the piston in place and thereby aids in sample retention, which is the principal benefit of the floating piston sampler.

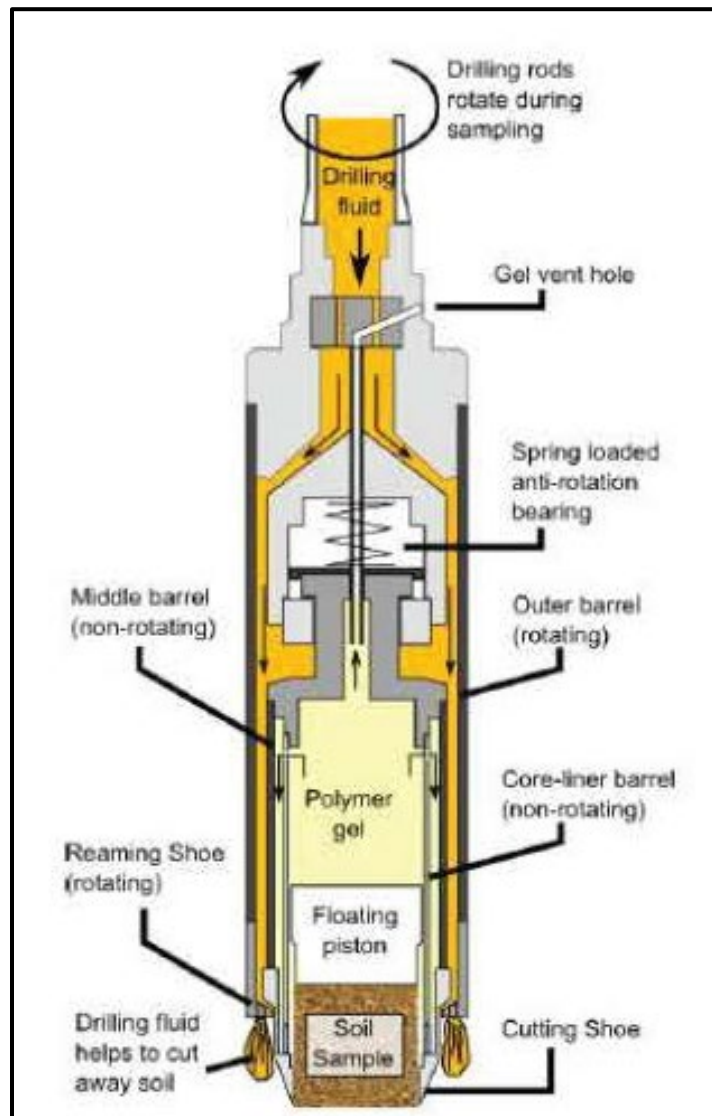
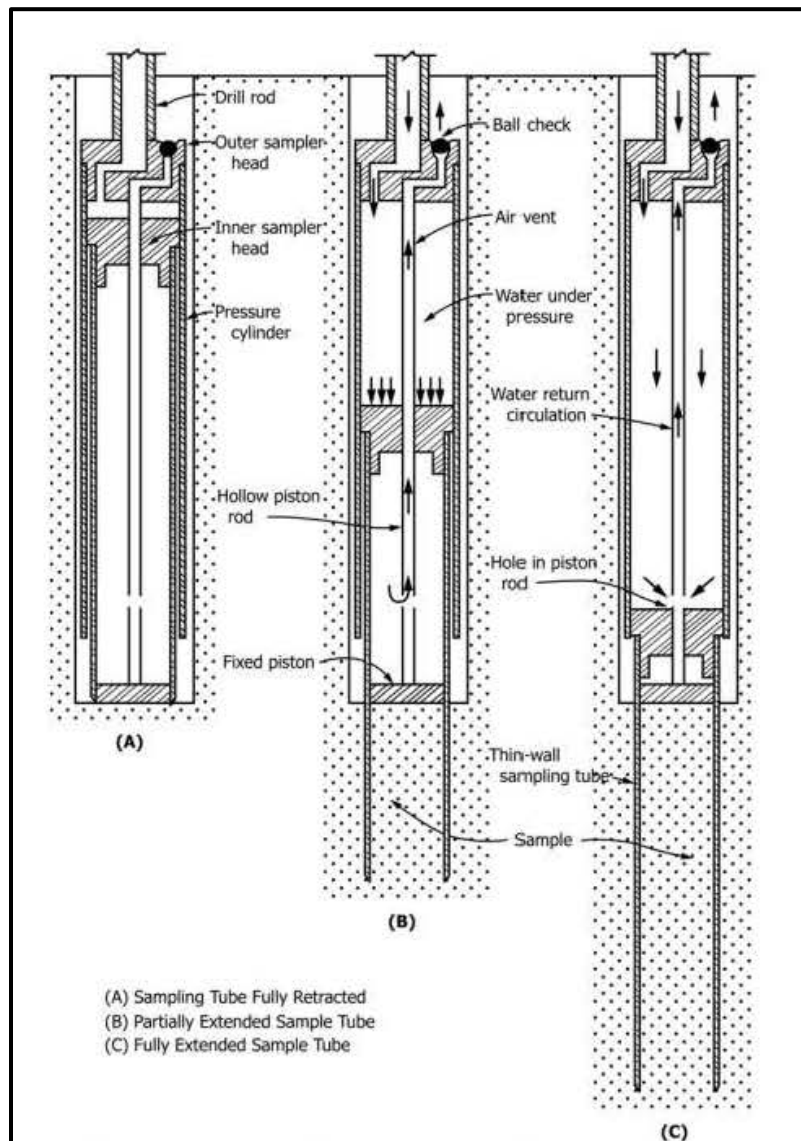

**Figure 5-2, Floating Piston Sampler
(Pineda (2016))**

5.2.1.3.4 Hydraulic (Osterberg) Piston Sampler

The principle of the hydraulic piston sampler (see Figure 5-3) is the same as a fixed piston sampler but the 2 devices differ in their operation. Rather than using activation rods to maintain the piston elevation during sampling, the hydraulic piston sampler uses the drill string for this purpose. Additionally, rather than using the drill string to push the sampling tube into the soil, the hydraulic sampler uses the drill rig water pump. The sampling tube is advanced hydraulically using the drilling water delivered to the sampler through the drill rods. The elimination of the activation rods makes this method faster than the fixed piston process. However, the push capacity using the available pressure from the drill rig water pump is less than the push capacity using the drill rig crowd. Therefore, use of the hydraulic piston sampler is limited to very soft to firm soils. See

ASTM D6519 – *Standard Practice for Sampling of Soil Using the Hydraulically Operated Stationary Piston Sampler.*



**Figure 5-3, Hydraulic Piston Sampler
 (Fonseca, Ferreira, Molina-Gomez and Ramos (2019))**

5.2.1.3.5 Retractable Piston Sampler

This sampler is similar to the fixed piston sampler; however, after lowering the sampler into position the piston is retracted and locked in place at the top of the sampling tube. A sample is then obtained by pushing the entire assembly downward. This sampler is used for loose or soft soils.

5.2.2 Rock Core Sampling

The most common method for obtaining rock samples is diamond core drilling. There are 3 basic types of core barrels: single tube, double tube, and triple tube. All rock cores shall be N-size and shall have an approximate 2-inch diameter; however, larger rock core diameters may be obtained

with prior approval of the OES/GDS. See ASTM D2113 - *Standard Practice for Rock Core Drilling and Sampling of Rock for Site Investigation* (AASHTO T225 - *Standard Method of Test for Diamond Core Drilling for Site Investigation*).

5.3 FIELD TESTING PROCEDURES

After access and utility clearances have been obtained and a survey base line has been established in the field, begin field explorations based on the subsurface exploration plan prepared by the GEOR. Many methods of field exploration exist; some of the more common are described below. These methods are often augmented by in-situ testing. The testing described in this Chapter provides the GEOR with soil and rock parameters determined in-situ. This is important on all projects, especially those involving soft clays, loose sands, or sands below the water table, due to the difficulty of obtaining representative samples suitable for laboratory testing. For each test included, a brief description of the equipment, the test method, and the use of the data is presented.

5.3.1 Test Pits

These are the simplest methods of inspecting subsurface soils. Test pits consist of excavations performed by hand, backhoe, or dozer. Hand excavations are often performed with posthole diggers. Test pits offer the advantages of speed and ready access for sampling; however, test pits are severely hampered by limitations of depth and by the fact that advancement through soft or loose soils or below the water table can be extremely difficult. Test pits are used to examine large volumes of near surface soils and can be used to obtain bulk samples for additional testing. Test pits are particularly useful in characterizing existing fill material when buried debris, trash, organics, etc., may be present or are suspected.

5.3.2 Soil Borings

Soil borings are the most common method of exploration. The results of the soil borings are presented on a Soil Test Log (see Chapter 6 for detailed description of the information presented on the log). In addition, to the description of the soils encountered, the Soil Test Log shall include the depth to groundwater both at the completion of the soil test boring and at least 24 hours later. Soil borings can be advanced using a number of methods. In addition, several different in-situ tests can be performed in the open borehole. The methods for advancing the boreholes will be discussed first followed by the methods of in-situ testing.

5.3.2.1 Manual Auger Borings

Manual auger borings are advanced using hand held equipment. Typically, these borings are conducted in areas where access for standard drilling equipment is severely restricted. Manual auger borings are limited in depth by the presence of ground water or collapsible soils that cause caving of the borehole. The Dynamic Cone Penetrometer test is usually conducted in conjunction with this boring method. A Manual Auger Boring Log and the results of the Dynamic Cone Penetrometer shall be prepared as indicated in Chapter 6.

5.3.2.2 Hollow Stem Auger Borings

A hollow-stem auger (HSA) consists of a continuous flight auger surrounding a hollow drill stem. The hollow-stem auger is advanced similar to other augers; however, removal of the hollow-stem

auger is not necessary for sampling. SPT and undisturbed samples are obtained through the hollow drill stem, which acts like a casing to hold the borehole open. This increases usage of hollow-stem augers in soft and loose soils. See ASTM D6151 - *Standard Practice for Using Hollow-Stem Augers for Geotechnical Exploration and Soil Sampling* (AASHTO T306 - *Standard Method of Test for Progressing Auger Borings for Geotechnical Explorations*). This drilling method is not appropriate in sand below the water table and therefore shall not be used in soils where sand below the water table is anticipated. This includes any Coastal county; the coastal portion of a Piedmont county; or river flood plain regardless of where the river is located. The use of HSA to start a wash rotary boring is not allowed without the express written permission of the RPG/GDS with concurrence from the OES/GDS.

5.3.2.3 Wash Rotary Borings

In this method, the boring is advanced by a combination of the cutting action of a light bit and the flushing action of water flowing upward from the bit. A downward pressure applied during rapid rotation advances the hollow drill rods with a cutting bit attached to the bottom. The drill bit cuts the material and drilling fluid, discharged from ports on the side of the drill bit, washes the cuttings from the borehole. This is, in most cases, the fastest method of advancing the borehole and can be used in any type of soil except those containing considerable amounts of large gravel or boulders. Drilling mud or casing can be used to keep the borehole open in soft or loose soils, although the former makes identifying strata change by examining the cuttings difficult. SPT and undisturbed samples are obtained through the drilling fluid, which holds the borehole open. This method of drilling shall be required in the following counties: Aiken, Allendale, Bamberg, Barnwell, Beaufort, Berkeley, Calhoun, Charleston, Chesterfield, Clarendon, Colleton, Darlington, Dillon, Dorchester, Florence, Georgetown, Hampton, Horry, Jasper, Kershaw, Lee, Lexington, Marion, Marlboro, Orangeburg, Richland, Sumter, and Williamsburg. These counties are typically located within the Coastal Plain Physiographic Province of South Carolina, with the remaining counties are located in the Piedmont Physiographic Province of South Carolina (see Chapter 11 for a detailed geologic discussion). However, the Coastal Plain extends into Edgefield, Fairfield, Lancaster and Saluda Counties, even though these counties are considered to be Piedmont counties. For those portions of these counties that are located in the Coastal Plain, wash rotary drilling methods shall be required. Additionally, wash rotary drilling methods shall be used at any locations where alluvium below the water table is anticipated, regardless of the county or proximity to the Coastal Plain. As previously indicated the use of HSAs to start wash rotary borings is not permitted without the express written permission of the RPG/GDS with concurrence from the OES/GDS. However, if the use of HSAs is permitted, the HSA drilling should not extend more than 3 feet below the existing ground surface.

5.3.2.4 Coring

A core barrel is advanced through rock by the application of downward pressure during rotation. Circulating water removes ground-up material from the hole while also cooling the bit. The rate of advance is controlled so as to obtain the maximum possible core recovery. See ASTM D2113 – *Standard Practice for Rock Core Drilling and Sampling of Rock for Site Investigation* (AASHTO T225 - *Standard Method of Test for Diamond Core Drilling for Site Investigation*). A professional geologist or engineer, with experience in geotechnical engineering and identifying rock, shall be on-site during coring operations to perform measurements in the core hole to allow for determination of the Geological Strength Index (GSI) and the Rock Mass Rating (RMR) (see Chapter 6) and other rock properties. An engineer-in-training, geologist-in-training or senior field

technician may observe the rock coring operations, provided written permission for the substitution is made prior to rock coring operations and the personnel meet the experience requirements established by the RPG/GDS. The RPG/GDS will provide written approval for the substitution. Rock coring, as indicated in Chapter 6, should begin when drilling refusal is encountered and an SPT N-value of 50 blows per 2 inches or less of penetration is encountered.

5.3.3 Standard Penetration Test

The SPT is one of the most widely used in-situ tests in the United States. It has the advantages of simplicity, the availability of a wide variety of correlations for its data, and the fact that a sample is obtainable with each test. A standard split-barrel sampler (discussed previously) is advanced into the soil by dropping a 140-pound manual safety or automatic hammer attached to the drill rod from a height of 30 inches. **[Note: Use of a donut hammer is not permitted]**. The sampler is advanced a total of 18 inches. The number of blows required to advance the sampler for each of 3 6-inch increments is recorded. The sum of the number of blows for the 2nd and 3rd increments is called the Standard Penetration Value, or more commonly, N-value (N_{meas}) (blows per foot). Tests shall be performed in accordance with ASTM D1586 - *Standard Test Method for Standard Penetration Test (SPT) and Split-Barrel Sampling of Soils* (AASHTO T206 - *Standard Method of Test for Penetration Test and Split-Barrel Sampling of Soils*). The Standard Penetration Test shall be performed every 2 feet in the upper 10 feet ($5 N_{meas}$) and every 5 feet thereafter. The exception is beneath embankments, where the Standard Penetration Test shall also be performed every 2 feet in the first 10 feet below the original ground surface. The depth to the original ground surface may be estimated based on the height of the existing embankment.

When the SPT is performed in soil layers containing large shells, gravels or similar materials, the sampler may become plugged. A plugged sampler will cause the SPT N-value to be much larger than for an unplugged sampler and, therefore, not a representative index of the soil layer properties. In this circumstance, a realistic design requires reducing the N-value used for design to the trend of the N-values which do not appear distorted. However, the actual N-values should be presented on the Soil Test Logs (see Chapter 6). A note shall be placed on the Soil Test Logs indicating that the sampler was likely plugged.

The SPT values should not be used indiscriminately. They are sensitive to the fluctuations in individual drilling practices and equipment. Studies have also indicated that the results are more reliable in sands than clays. Although extensive use of this test in subsurface exploration is recommended, it should always be augmented by other field and laboratory tests, particularly when dealing with clays. The type of hammer (safety or automatic) shall be noted on the boring logs, since this will affect the actual input driving energy. N_{meas} requires correction prior to being used in engineering analysis (see Chapter 7).

The amount of driving energy shall be measured using ASTM D4633 - *Standard Test Method for Energy Measurement for Dynamic Penetrometers*. Since there is a wide variability of performance in SPT hammers, this method is used to evaluate an individual hammer's performance. The energy of a hammer can be effected by the mechanical state of the hammer system (i.e., maintained or not), the condition of the rope, the experience of the driller, the time of day, and the weather. A Quality Assurance/Quality Control (QA/QC) plan for measuring hammer energy shall be submitted for review and acceptance by the RPG/GDS, prior to being used in the field.

The SPT installation procedure is similar to pile driving because it is governed by stress wave propagation. As a result, if force and velocity measurements are obtained during a test, the energy transmitted can be determined.

5.3.4 Dynamic Cone Penetrometer Test

The Dynamic Cone Penetrometer (DCP) Test is a dynamic penetration test usually performed in conjunction with manual auger borings. DCP testing shall be conducted using the procedure presented by Sowers and Hedges (1966). The DCP resistance values shall be correlated to N_{meas} , by performing an SPT adjacent to a DCP test location. As an alternate to the Sowers and Hedges (1966) procedure, the DCP may also be conducted using ASTM D6951 – *Standard Test Method for Use of the Dynamic Cone Penetrometer in Shallow Pavement Applications*.

5.3.5 Cone Penetrometer Test

The Cone Penetrometer Test is a quasi-static penetration test in which a cylindrical rod with a conical point is advanced through the soil at a constant rate and the resistance to penetration is measured. A series of tests performed at varying depths at 1 location is commonly called a sounding.

Several types of cone penetrometers have been historically used, including the mechanical (Dutch) cone, mechanical friction-cone, electric cone, and electric friction-cone but these are now obsolete. All Cone Penetrometer Testing on SCDOT projects shall use electro-piezocone (CPTu) penetrometers. Standard cone penetrometers measure 3 main parameters: 1) resistance to penetration at the conical tip of the penetrometer, 2) resistance acting on a cylindrical friction sleeve which is mounted behind the conical tip, and 3) water pressure acting at the joint between the conical tip and the friction sleeve also known as the u_2 position. All 3 measurements are made nearly continuously (e.g., every 2 cm (~3/4-inch)) with depth. Many cone penetrometers also have the ability to measure inclination during penetration and specialized cones may include additional capabilities (e.g., instrumentation for shear wave velocity measurements, resistivity, fuel fluorescence, etc.).

For all types of penetrometers, cone dimensions of a 60-degree tip angle and a 10 cm^2 (1.55 in²) or 15 cm^2 (2.33 in²) projected end area are standard. Friction sleeve outside diameter is the same as the base of the cone. Penetration rates should be between 10 to 20 mm/sec. Tests shall be performed in accordance with ASTM D5778 - *Standard Test Method for Electronic Friction Cone and Piezocone Penetration Testing of Soils*. Prior to being used on a SCDOT project, all electro-piezocones shall be calibrated to ascertain that the internal components of the cone are working correctly. Calibration of the cone shall comply with the requirements of Section 5.5. In addition, prior to performing each sounding and immediately after completion of the sounding, the zero readings of the cone shall be obtained. If the before “zero reading” is different from the after “zero reading”, the GEC shall determine if the cone is working properly. Further, the GEC shall determine if the different “zero readings” affect the results of the sounding. If the sounding is affected, then the GEC shall contact the RPG/GDS with this information along with recommendations as to what corrective action is required. If there is no change between the before “zero reading” and the after “zero reading”, then the “zero reading” shall be used to correct the results of the sounding.

The measured parameters (i.e., tip resistance, sleeve resistance, and pore pressure) can be used with various classification methods to determine the soil behavior type. Many correlations of the cone test results to other soil parameters have been made, and design methods are available for spread footings and piles. The cone penetrometer can be used in sands or clays, but not in rock or other extremely dense soils. Since samples are not obtained during a CPTu sounding, the exploration should be augmented by push-tube sampling, SPT borings or other borings with soil samples taken. On SCDOT projects, the CPTu soil behavior type (I_c) shall be correlated to the in-situ soils by performing a boring adjacent to the sounding. Only a single correlation boring shall be required, if in the opinion of the GEOR the site is uniform. If the site is not uniform, then the GEOR shall determine if additional correlation borings are required. The soil test boring shall be continuously sampled for the upper 50 feet and sampled every 5 feet thereafter to the anticipated depth of CPTu sounding termination or the actual depth of CPTu sounding termination whichever is shallower. The soil test boring shall be located no more than 5 feet from the location of the CPTu sounding and shall be located at the same approximate elevation. A professional engineer or professional geologist shall classify the soil samples obtained from the boring using both visual classification methods as well as index testing. Then the professional engineer or professional geologist shall compare the classifications from the soil test boring to the soil behavior type classifications indicated by the CPTu sounding. Differences between the soil classification of the samples from the boring and the soil behavior type from the CPTu data shall be reflected in subsequent use and presentation of the CPTu data (e.g., on subsurface cross sections).

As indicated in Chapter 4, the CPTu may be used to measure the dissipation rate of the excessive pore water pressure for all soils identified as fine-grained with a thickness of more than 3 feet. At the option of the GEOR, thinner layers may have pore pressure dissipation tests. The cone should be equipped with a pressure transducer that is capable of measuring the induced water pressure. To perform this test, the cone will be advanced into the subsoil at a standard rate of 20 mm/sec. Excess pore water pressures will be measured immediately and at several time intervals thereafter. Use the recorded data to plot pore pressure dissipation versus log-time graph. Using this graph, an estimate of the permeability and/or coefficient of consolidation can be made. In addition an Excel® spreadsheet that contains the data from the test shall be provided (indicated in Chapter 6).

5.3.6 Dilatometer Test

The dilatometer is a 3.75-inch wide and 0.55-inch thick stainless steel blade with a thin 2.4-inch diameter expandable metal membrane on 1 side. While the membrane is flush with the blade surface, the blade is pushed into the subsurface. The thrust required to insert the dilatometer ranges from 2 to 15 tons, but should be limited to less than 5 tons to prevent damage to the dilatometer. Alternatively, the dilatometer can be driven to the required testing interval using a SPT hammer. However, extreme caution is required when driving the dilatometer to prevent damage to the instrument. Rods carry pneumatic and electrical lines from the membrane to the surface. Individual dilatometer tests are typically conducted at depth intervals of 12 inches. Tests shall be performed in accordance with ASTM D6635 - *Standard Test Method for Performing the Flat Plate Dilatometer*. A pressurized gas (a bottle of nitrogen) is used to expand the membrane into the soil. Three readings or pressures are measured during the test. According to The Flat Dilatometer Test, Publication No. FHWA-SA-91-044 (Briaud and Miran (1992B)), these readings are:

1. A-pressure – gas pressure against the inside of the membrane when the center of the membrane has lifted above its support and moved horizontally into the surrounding soil 0.05 mm
2. B-pressure – gas pressure against the inside of the membrane when the center of the membrane has lifted above its support and moved horizontally into the surrounding soil 1.1 mm
3. C-pressure – gas pressure against the inside of the membrane obtained by slowly deflating the membrane until contact is reestablished

According to Briaud and Miran (1992B), the dilatometer is calibrated in the air under atmospheric pressure, both before and after the test: “The gas pressure necessary to overcome the membrane stiffness and move it in the air to both the A position and B position are referred to as ΔA and ΔB , respectively; they are not negligible.” If the membrane calibration is conducted using the same gauge as used in the field testing, then Z_M (see Chapter 6) shall be set to 0. The reason is that the Z_M correction is already accounted for in the membrane calibration. New membranes will have calibration values outside of the anticipated values (see Table 5-1). In order to get the membrane calibration values into the range of anticipated values the new membrane should be exercised prior to being used for testing. Exercising should continue until the calibration values are within the anticipated values. “S” (standard) type membranes are relatively soft and should only be used when the anticipated thrust to advance the dilatometer is less than 2 tons. “H” (high strength) type membranes are strong and can be used in any soil. Therefore, the “H” type membrane should be the membrane typically used.

**Table 5-1, Expected Calibration Values
(Briaud and Miran (1992B))**

Membrane Type	ΔA Calibration (bars)			ΔB Calibration (bars)		
	Minimum	Maximum	Average	Minimum	Maximum	Average
Standard “S”	0.10	0.20	0.13	0.10	0.70	0.35
High Strength “H”	0.10	0.25	0.19	0.10 ¹	1.50	0.90 ²

¹ $\Delta B < 0.30$ is unusual for “H” membranes and may indicate damage

²Considerable variation

The thrust (q_d) is typically measured at the ground surface; therefore, the resistance of the rods will need to be subtracted from the total thrust to obtain the thrust just to insert the blade. The resistance of the rods may be determined in several ways, first, estimate the required resistance on the push rods and reduce the total thrust to get the blade thrust. Second, measure the thrust encountered during dilatometer insertion, measure the thrust required to extract the dilatometer, with the difference between the 2 measurements being the thrust required to insert just the dilatometer blade. The final way to estimate thrust is to assume the tip stress (q_c) required to insert a nearby cone is the same as the thrust required to insert the dilatometer. An Excel[®] spreadsheet that contains the data from the test shall be provided (indicated in Chapter 6). Further, the Excel[®] spreadsheet shall indicate the type of membrane used.

5.3.7 Pressuremeter Test

This test is performed with a cylindrical probe placed at the desired depth in a borehole. The Menard type pressuremeter requires pre-drilling of the borehole; the self-boring type pressuremeter advances the hole itself, thus reducing soil disturbance. The PENCEL pressuremeter can be set in place by pressing it to the test depth or by direct driving from ground

surface or from within a predrilled borehole. The hollow center PENCEL probe can be used in series with the static cone penetrometer. The borehole should have a diameter ranging from 1.03D to 1.2D, where D is the diameter of the pressuremeter. The Menard type pressuremeter shall have a length to diameter (L/D) ratio of at least 6.5:1 to minimize end effects. The pressuremeter membrane typically has a slotted tube or a Chinese screen covering to protect the membrane from punctures during inflation. In soils the membrane is inflated using either water (typical) or gas, while in weathered and fractured rocks hydraulic oil is used. Tests shall be performed in accordance with ASTM D4719 - *Standard Test Methods for Prebored Pressuremeter Testing in Soils*.

Prior to proposing or conducting the Pressuremeter Test (PMT), the GEOR shall contact the RPG/GDS to discuss the anticipated testing results and the use of these testing results in design. In addition to the plotted pressuremeter data, the GEC shall provide to the RPG/GDS an electronic file in Excel® format providing at least the following data:

1. Depth (feet)
2. p_o (psf)
3. p_f (psf)
4. p_u (psf)
5. p_r (psf)
6. p_L (psf)
7. Creep Test

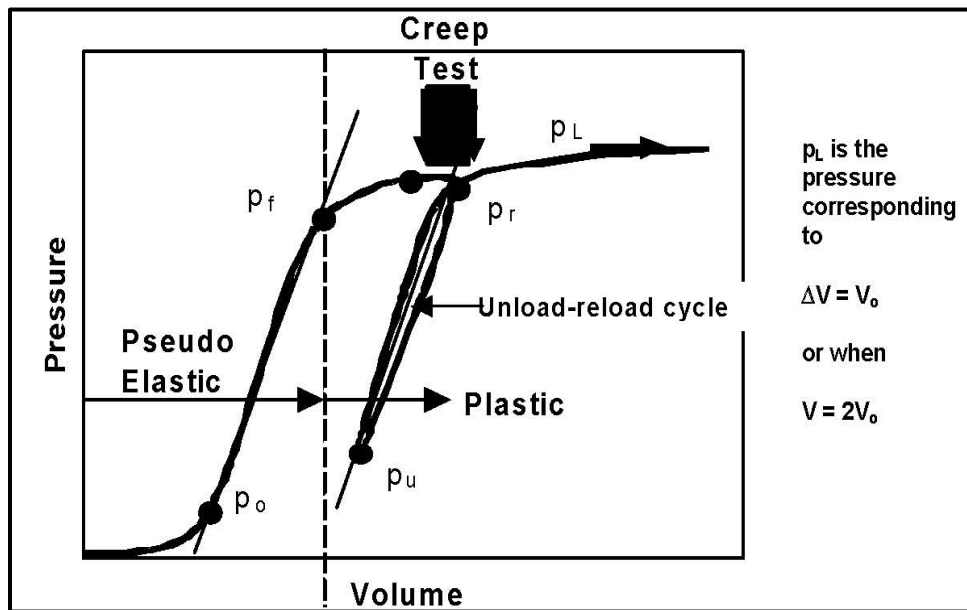

Figure 5-4, Pressuremeter Curve
(Sabatini, Bachus, Mayne, Schneider and Zettler (2002))

Where,

- p_o – Pressure at which recompression of the disturbed soil is complete and expansion into undisturbed soil begins
- p_f – Pressure where the soil changes from pseudo-elastic to plastic shear
- p_u – Minimum pressure during unloading, in the unload-reload cycle
- p_r – Pressure at the point during the reload portion in the unload-reload cycle where recompression ends and plastic shearing reinitiates

- p_L – Pressure at which curve becomes asymptotic to pressure regardless of the increase of volume; extrapolated as the pressure when the volume is equal to twice the initial volume of the pressuremeter
- Creep Test – Prior to performing an unload-reload test, a creep test should be performed, continued deformation at a constant pressure until strain rates of 0.1 percent per minute are recorded

In addition, the OES/GDS will determine what correlated design parameters from the PMT shall be provided. Contact the OES/GDS for instructions on log preparation and presentation of PMT data.

Results are interpreted based on semi-empirical correlations from past tests and observation. In-situ horizontal stresses, shear strength, bearing capacities, and settlement can be estimated using these correlations. The pressuremeter test results can be used to obtain load displacement curves (p-y curves) for lateral load analyses. The pressuremeter test is very sensitive to borehole disturbance and the data may be difficult to interpret for some soils.

5.3.8 Field Vane Shear Test

The Field Vane Shear Test (FVST) consists of advancing a 4-bladed vane into cohesive soil to the desired depth. The field vane should be advanced a minimum of 4 times the diameter of the borehole to allow for testing undisturbed soils. The field vane shall have a minimum height (H) to diameter (D) ratio of at least 2 (see Figure 5-5). In addition, the field vane has 2 basic configurations rectangular or tapered (see Figure 5-5). In the tapered configuration some vanes only have a tapered edge along the bottom of the vane which affects the way the undrained shear strength is determined (see Chapter 7). Torque is applied at a constant rate ($6^\circ/\text{min}$ ($0.1^\circ/\text{sec}$)) until the soil fails in shear along a cylindrical surface. The torque measured (T_{net}) at failure provides the undrained shear strength ($(S_u)_{\text{fvst}}$) of the soil. After determining the torque required for initial failure ($(S_u)_{\text{fvst}}$), the vane is quickly rotated through 10 complete revolutions and the remolded undrained shear strength ($(S_{\text{urem}})_{\text{fvst}}$) is determined using T_{net} for these revolutions. Using the undrained shear strengths (peak and remolded) the sensitivity of the soil may be determined. Tests shall be performed in accordance with ASTM D2573 - *Standard Test Method for Field Vane Shear Test in Cohesive Soil* (AASHTO T223 - *Standard Method of Test for Field Vane Shear Test in Cohesive Soil*).

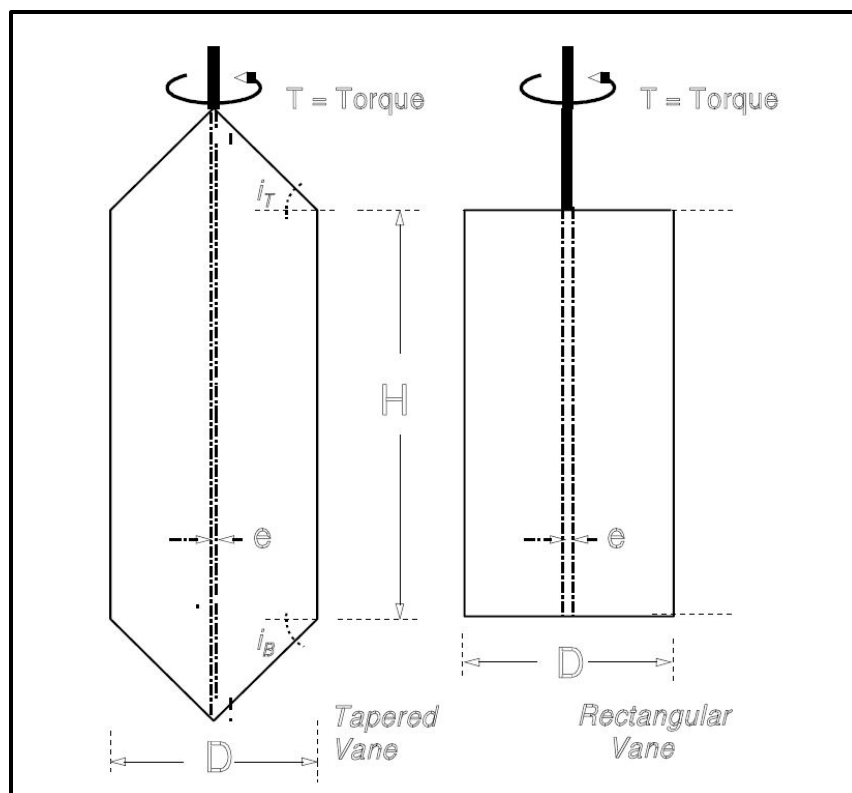

**Figure 5-5, Field Vane Devices
(Mayne, Christopher and DeJong (2002))**

$$T_{net} = T_{max} - T_{rod} \quad \text{Equation 5-1}$$

Where,

D – Diameter of the field vane

H – Height of the field vane (see Figure 5-5)

e – Thickness of the vanes

i_T and i_B – Angle measured from the horizontal of the taper (up (T) or down (B))

T_{net} – Net torque

T_{max} – Maximum torque at peak undrained shear strength

T_{rod} – Torque on rod caused by skin friction

The correlations for $(S_u)_{fvst}$, $(S_{urem})_{fvst}$ and $S_{t(fvst)}$ (sensitivity) shall conform to the requirements of Chapter 7. The GEC shall provide the results of the FVST in an Excel® spreadsheet. The data from the FVST shall be presented as indicated in Chapter 6. This method is commonly used for measuring shear strength in soft clays (anticipated shear strength less than 2 tsf) and organic deposits. It should not be used in stiff and hard clays. Results can be affected by the presence of gravel, shells, roots, or sand layers. Shear strength may be overestimated in plastic clays ($PI > 5$) and a correction factor (μ_v) should be applied.

$$\tau_{mobilized} = \mu_v * (S_u)_{fvst} \quad \text{Equation 5-2}$$

$$\mu_v = 1.05 - 0.45 * (PI)^{0.5} \quad \text{Equation 5-3}$$

Where,

PI – Plasticity index

μ_v – Empirical correction factor

$\tau_{\text{mobilized}}$ – Mobilized shear strength

5.3.9 Double-Ring Infiltrometer Test

The double-ring infiltrometer test is used to determine the rate of water infiltration into the subgrade soils. Infiltration rates are typically required in the design of storm water retention structures. The test consists of using 2 concentric metal rings that are inserted into the ground. Water is added to the outer ring and allowed to soak into the soil, with more water added to keep the water in the outer ring at the same depth. Once the water level in the outer ring stays constant, water is added to the inner ring until the water level in the inner ring is the same as the level in the outer ring. As soon as the water level in the 2 rings is the same, the change in the water level of the inner ring is recorded with time. The test is repeated with successively longer time intervals until the infiltration rate is constant with time and the infiltration rate can be determined. Tests shall be performed in accordance with ASTM D3385 - *Standard Test Method for Infiltration Rate of Soils in Field Using Double-Ring Infiltrometer*. Contact the OES/GDS for instructions on presentation of data.

5.3.10 Geophysical Testing Methods

Geophysical testing methods are non-destructive testing procedures which can provide general information on the general subsurface profile, depth to bedrock or water, location of granular borrow areas, peat deposits or subsurface anomalies and provide an indication of certain material properties (i.e., compression wave velocity (V_p) and shear wave velocity (V_s)). Geophysical testing methods are not limited to subsurface conditions, but can also be used to evaluate existing bridge decks, foundations and pavements. The reader should see [Application of Geophysical Methods to Highway Related Problems](#), FHWA-IF-04-021 (Wightman, et al. (2003)), for additional information on the application of geophysical test methods to other areas other than subsurface conditions.

5.3.10.1 Surface Shear Wave Velocity Methods

Surface wave methods consist of Spectral Analysis of Surface Waves (SASW) or Multi-channel Analysis of Surface Waves (MASW). The SASW and MASW are used to measure layer thickness, depth and the shear wave velocity (V_s) of the layer. The shear wave velocity is more of bulk (general) velocity than a discrete velocity of a layer. Discrete shear wave velocity may be determined by crosshole or downhole methods. While the SASW will typically have 2 geophones (see Figure 5-6), the MASW will have additional geophones spread over a larger area. Typically SASW and the MASW profiles are limited to a depth of approximately 130 feet using man portable equipment. Additional depth can be obtained but heavier motorized equipment is required. The GEC shall provide the results of the testing in an Excel[®] spreadsheet. See Chapter 6 for presentation of SASW/MASW data.

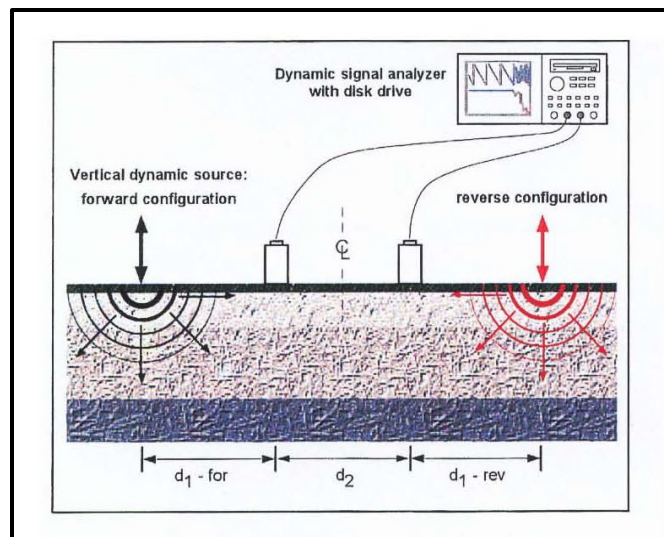

**Figure 5-6, SASW Shear Wave Velocity Testing
(Mayne et al. (2002))**

5.3.10.2 Downhole Seismic Methods

Downhole methods for determining shear and compression wave velocities differ from surface methods in that equipment is placed in the ground (see Figure 5-7). In downhole methods, either, a casing is placed in the ground and a pair geophones are lowered into the casing or a seismic cone penetrometer (SCPTu) is pushed into the ground. The SCPTu should have 2 geophones or accelerometers mounted above the friction sleeve on the cone. The transducers in either method shall be capable of measuring in orthogonal directions (i.e., 1 vertical and 2 horizontal at 90° to each other). With either method, a shear and/or compression wave is induced at the ground surface and the time for arrival is determined. For conventional downhole testing in a borehole, the casing must be grouted in place with a non-shrink grout. As compared to the casing method, SCPTu is much faster but has the major limitation of refusal to advance in dense soils. Tests shall be performed in accordance with ASTM D7400 – *Standard Test Methods for Downhole Seismic Testing*. The GEC shall provide the results of the testing in an Excel® spreadsheet. The spreadsheet shall include both V_p and V_s , the depth of each reading, and the estimated unit weight at each reading. See Chapter 6 for presentation of Downhole Seismic Velocity data (i.e., shear and compression wave velocity).

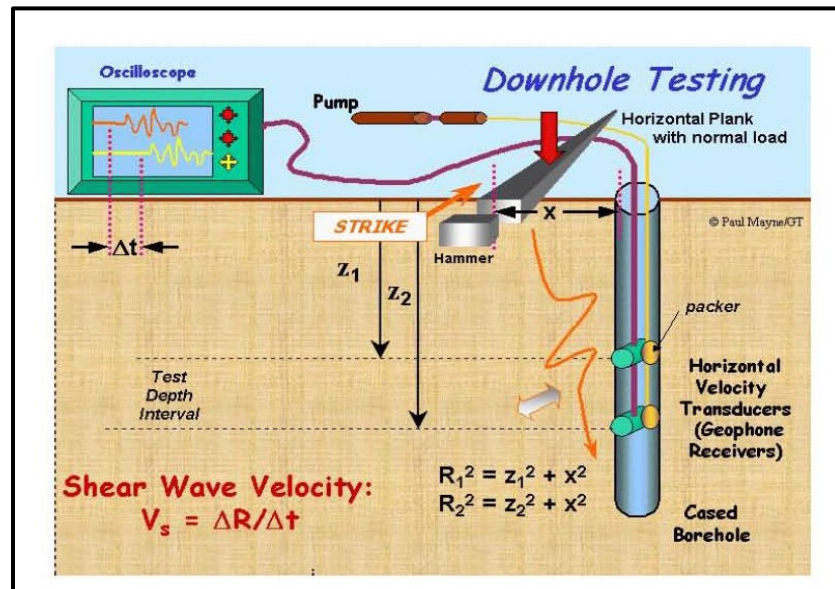
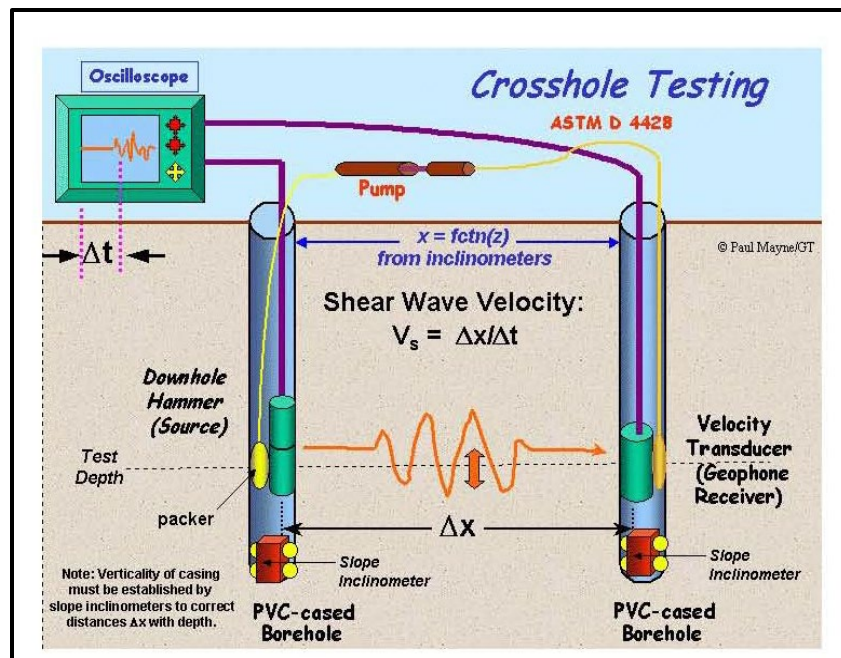

Figure 5-7, Downhole Seismic Testing
(Mayne et al. (2002))

5.3.10.3 Crosshole Seismic Methods

In crosshole seismic testing, both shear and compression wave velocities are determined between a series of cased boreholes (see Figure 5-8). A downhole hammer and geophone are lowered to the same depth, but in different holes. The hammer is tripped and time for the shear or compression wave to travel to the geophone is recorded. The major limitation to the crosshole method is the expense of the installation of the required cased borehole. In addition, care must be taken during the construction of the casings to assure that the casings are plumb and in the same horizontal plane and are in good contact with the surrounding soil. Depending on the depth and spacing between the cased boreholes, a verticality survey with an inclinometer may be necessary to determine the actual spacing between the boreholes at the test depths. Tests shall be performed in accordance with ASTM D4428 – *Standard Test Methods for Crosshole Seismic Testing*. The GEC shall provide the results of the testing in an Excel® spreadsheet. The spreadsheet shall include both V_p and V_s , depth of each reading, and the estimated unit weight at each reading. See Chapter 6 for presentation of Crosshole Seismic Velocity data (i.e., shear and compression wave velocity).



**Figure 5-8, Crosshole Seismic Testing
(Mayne et al. (2002))**

5.3.10.4 Suspension Logging

Suspension logging is a borehole geophysical technique used to measure compression and shear wave (V_p and V_s , respectively) velocities. Unlike the downhole or crosshole methods, the use of casing is not required; in fact the use of no casing is preferred. The receivers and source have the same polarity (axis). A schematic diagram of suspension logging is depicted in Figure 5-9. Energy from the source is transmitted through the borehole fluid to the borehole walls, where the energy is converted into P- and S-waves radiating out from the borehole wall. These waves travel up the soil column and pass the 2 receivers, which are located 1 meter apart. The time between energy wave generation and the time for first arrival at each receiver is recorded. The V_p and V_s can be developed from the arrival times and the distance between the receivers. Advantages and limitations are presented in Diehl, Martin and Steller (2006). Suspension logging shall conform to the requirements of ASTM D5753 – *Standard Guide for Planning and Conducting Borehole Geophysical Logging*. In addition, the testing methodology for the suspension logging shall be provided by the GEC to the RPG/GDS and OES/GDS prior to commencing field work. The GEC shall provide the results of the testing in an Excel® spreadsheet. The spreadsheet shall include both V_p and V_s , the depth of each reading, and the estimated unit weight at each reading.

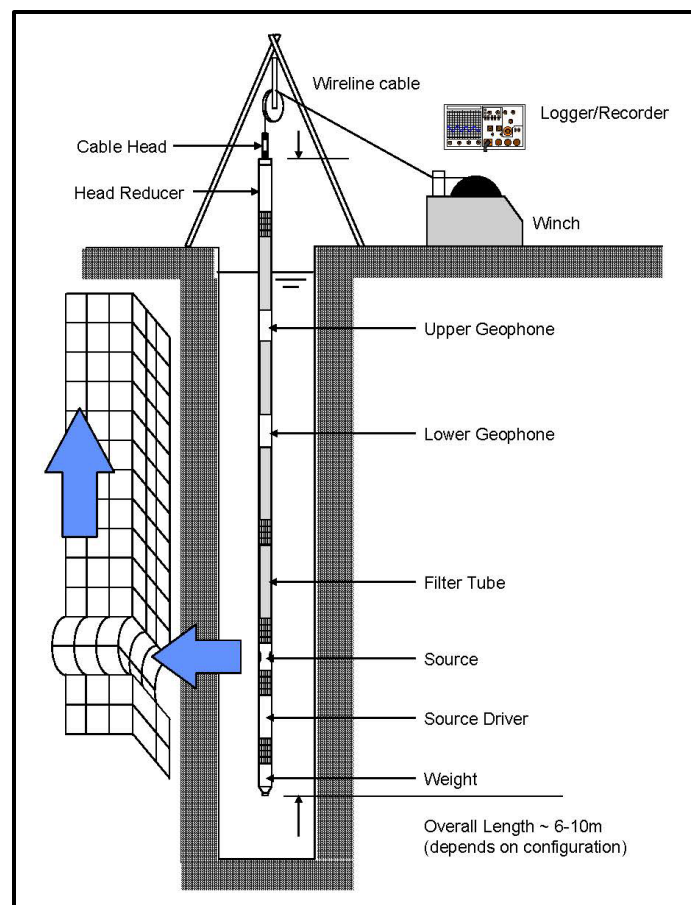
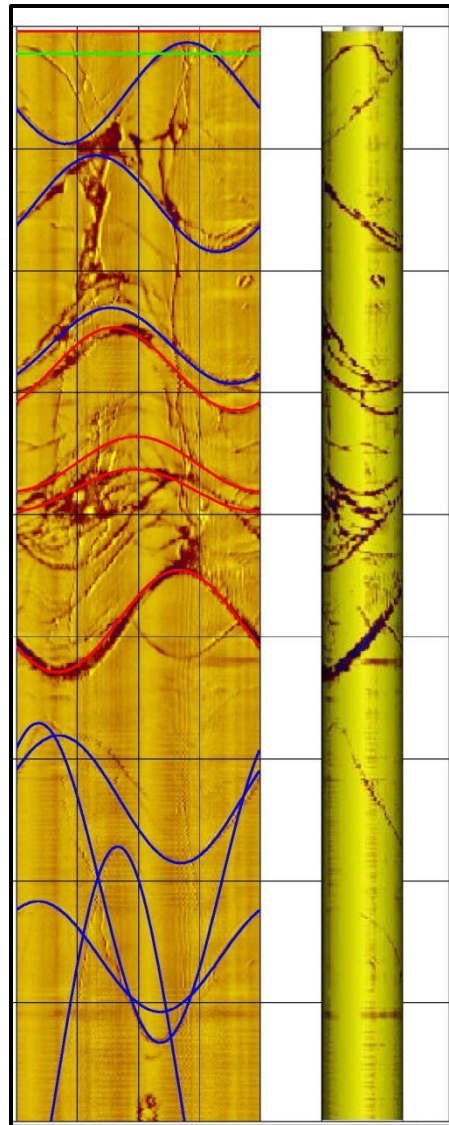

**Figure 5-9, Suspension Logging Schematic
(Diehl, Martin and Steller (2006))**

5.3.10.5 Acoustic Televiwer

The acoustic televiwer uses an acoustic signal to obtain an oriented image of a borehole. It is anticipated that this testing method will only be used in boreholes that extend into rock where obtaining cores is difficult, expensive or are simply not available. The acoustic signal is generated by a rotating sonar transducer, which produces an “image” of the borehole. The image can be presented 2 different ways either as a wrapped core (Figure 5-10 – left hand image) or as an unwrapped image, viewed from the center of the borehole (Figure 5-10 – right hand image). From the data obtained void and joint data may be presented in terms of depth, direction of dip (with respect to North), dip angle and strike.

The preferred piece of equipment is a high-resolution acoustic televiwer. The use of a high-resolution acoustic televiwer allows the “image” to be presented in “pseudo-color”. Breaks and voids in the rock will appear as dark lines on the image. The acoustic televiwer shall conform to the requirements of ASTM D5753 - *Standard Guide for Planning and Conducting Borehole Geophysical Logging*. In addition, the testing methodology for the acoustic televiwer shall be provided by the GEC to the RPG/GDS and OES/GDS prior to commencing field work. The GEC shall provide the results of the testing in an Excel[®] spreadsheet. Contact the OES/GDS for instructions on data presentation.



**Figure 5-10, Acoustic Televiewer Image
(GEOVision (2014))**

5.3.10.6 Seismic Refraction

Seismic refraction is primarily used to determine the depth to bedrock. This method works well for depths less than 100 feet. A seismic energy source is required for producing seismic waves (see Figure 5-11). A sledge hammer is typically used for depths less than 50 feet and either a drop weight or a black powder charge is used for depths between 50 and 100 feet. The seismic compression waves penetrate the overburden material and refract along the bedrock surface. This method can be used for up to 4 soil layers on rock layers; however, each layer must have a higher shear wave velocity than the overlying layer. Figure 5-12 provides an example of determining the depth to rock in a 2-layer system. Tests shall be performed in accordance with ASTM D5777 – *Standard Guide for Using the Seismic Refraction Method for Subsurface Investigation*. The GEC shall provide the results of the testing in an Excel® spreadsheet. Contact the OES/GDS for instructions on data presentation.

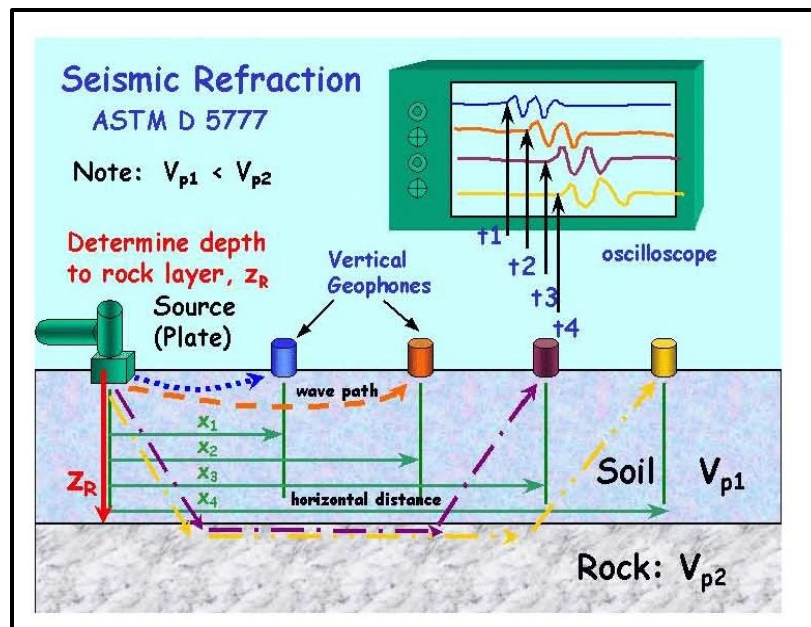

Figure 5-11, Seismic Refraction Testing (Mayne et al. (2002))

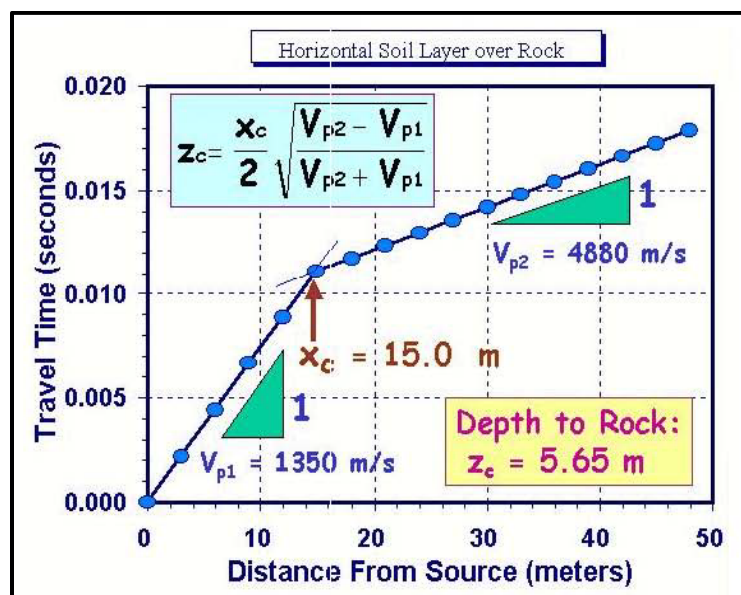

Figure 5-12, Data Reduction Example for Determining Depth to Hard Layer (Mayne et al. (2002))

5.3.10.7 Seismic Reflection

Seismic reflection uses a surface seismic wave source to create seismic waves that can penetrate the subsurface. The waves are reflected at interfaces that have either a change in shear wave velocity and/or a change in density. Changes in velocity or density are termed impedance contrasts. At impedance contrasts, a portion of the seismic wave is reflected back to the ground surface and a portion continues into the subsurface where it is reflected at the next impedance contrast. Seismic reflection techniques can obtain information in excess of 100 feet. Tests shall be performed in accordance with ASTM D7128 – *Standard Guide for Using the Seismic-Reflection*

Method for Shallow Subsurface Investigation. Contact the OES/GDS for instructions on the presentation of the data.

5.3.10.8 Resistivity

Resistivity is used to find the depth to bedrock since soil and rock typically have different electrical resistances. The depth of the resistivity survey is typically 1/3 of the electrode spacing. For example, to reach a depth of 50 feet an electrode spacing of 150 feet is required. Resistivity surveys can reach depths of 160 feet. Resistivity testing is affected by the moisture content of the soil and the presence or lack of metals, salts and clay particles. In addition, resistivity surveys may be used to model ground water flow through the subsurface. Further, resistivity surveys may also be used to determine the potential for corrosion of foundation materials for the in-situ subsurface materials. Tests shall be performed in accordance with either ASTM D6431 – *Standard Guide for Using the Direct Current Resistivity Method for Subsurface Investigation* or ASTM G57 – *Standard Test Method for Field Measurement of Soil Resistivity Using the Wenner Four-Electrode Method*. Contact the OES/GDS for instructions on the presentation of data.

5.4 SOIL/ROCK LABORATORY TESTING

5.4.1 Grain-Size Analysis

There are 2 types of grain-size analysis tests: grain-size with wash No. 200 and the hydrometer test. Grain-size with wash No. 200, also known as Sieve Analysis, is for coarse-grained soils (sand, gravels) while the hydrometer test mainly is used for fine-grained soils (clays, silts). The results of the analyses are presented as depicted in Chapter 6.

The grain-size analysis can also be used for obtaining 3 basic soil parameters from the curves. These parameters are: effective size (D_{10}), Coefficient of Uniformity (C_u), and Coefficient of Curvature (C_c). As required in Chapter 4, a hydrometer test and grain-size analysis shall be performed on selected samples to determine the D_{50} , which is used in scour analysis by the HEOR. The results of the testing are presented as indicated in Chapter 7.

5.4.1.1 Sieve Analysis

The sieve analysis is a method used to determine the grain-size distribution of soils between the 3-inch sieve and the No. 200 sieve. The soil is passed through a series of woven wires with square openings of decreasing sizes. The test gives a soil classification based on the percentage retained on each sieve. See ASTM D6913 - *Standard Test Method for Particle-Size Distribution (Gradation) of Soils Using Sieve Analysis*. The amount passing the No. 200 sieve shall be determined in accordance with ASTM D1140 – *Standard Test Method for Amount of Material in Soils Finer than No. 200 (75- μ m) Sieve*. For gradations of particles greater than the 3-inch sieve in accordance with ASTM D5519 – *Standard Test Method for Particle Size Analysis of Natural and Man-Made Riprap Materials*.

5.4.1.2 Hydrometer

The hydrometer analysis is used to determine the particle size distribution in a soil that is finer than a No. 200 sieve size (0.075 mm), which is the smallest standard size opening in the sieve analysis. The procedure is based on the sedimentation of soil grains in water. It is expressed by Stokes Law, which states that the velocity of the soil sediment is based on the soil particles shape,

size and weight, as well as the viscosity of the water. Thus, the hydrometer analysis measures the change in specific gravity of a soil-water suspension as soil particles settle out over time. See ASTM D7928 - *Standard Test Method for Particle-Size Distribution (Gradation) of Fine-Grained Soils Using the Sedimentation (Hydrometer) Analysis* (AASHTO T88 - *Standard Method of Test for Particle Size Analysis of Soils*).

5.4.2 Moisture Content

The moisture content (w) is defined as the ratio of the weight of water in a sample to the weight of solids. The weight of the solids must be oven dried and is considered as weight of dry soil. Organic soils can have the moisture content determined, but must be dried at a lower temperature for the weight of dry soil to prevent degradation of the organic matter. See ASTM D2216 - *Standard Test Methods for Laboratory Determination of Water (Moisture) Content of Soil and Rock by Mass* (AASHTO T265 - *Standard Method of Test for Laboratory Determination of Moisture Content of Soils*). It is noted that the terms “moisture content” and “water content” are used interchangeably.

5.4.3 Atterberg Limits

The Atterberg Limits are different descriptions of the moisture content of fine-grained soils as it transitions from a solid to a liquid-state (also termed the moisture-plasticity relationship). For classification purposes the 2 primary Atterberg Limits used are the plastic limit (PL) and the liquid limit (LL). The plasticity index (PI) is also calculated for soil classification.

5.4.3.1 Plastic Limit

The PL is the moisture content at which a soil transitions from being in a semisolid state to a plastic state. Tests shall be performed in accordance with ASTM D4318 - *Standard Test Methods for Liquid Limit, Plastic Limit, and Plasticity Index of Soils* (AASHTO T90 - *Standard Method of Test for Determining the Plastic Limit and Plasticity Index of Soils*).

5.4.3.2 Liquid Limit

The LL is defined as the moisture content at which a soil transitions from a plastic state to a liquid state. Tests shall be performed in accordance with ASTM D4318 - *Standard Test Methods for Liquid Limit, Plastic Limit, and Plasticity Index of Soils* (AASHTO T89 - *Standard Method of Test for Determining the Liquid Limit of Soils*).

5.4.3.3 Plasticity Index

The PI is defined as the difference between the LL and the PL of a soil. The PI represents the range of moisture contents within which the soil behaves as a plastic solid.

$$PI = LL - PL$$

Equation 5-4

5.4.4 Specific Gravity of Soils

The specific gravity of soil, G_s , is defined as the ratio of the unit weight of a given material to the unit weight of water. The procedure is applicable only for soils composed of particles smaller than the No. 4 sieve (4.75 mm). This test shall be performed in conjunction with all consolidation tests. See ASTM D854 - *Standard Test Methods for Specific Gravity of Soil Solids by Water Pycnometer* (AASHTO T100 - *Standard Method of Test for Specific Gravity of Soils*). If the soil contains particles larger than the No. 4 sieve (4.75 mm), use ASTM C127- *Standard Test Method for Density, Relative Density (Specific Gravity), and Absorption of Coarse Aggregate*.

5.4.5 Undisturbed Sample Preparation

Strength and consolidation testing require the use of undisturbed (Shelby tube) samples, to avoid unnecessarily compromising the samples, extreme care is required in the transportation and handling of this samples. These samples shall be transported in a manner to minimize shaking and shall be oriented vertically with the top of the sample at the top of the carrier used to hold the tubes during transportation to the laboratory. Upon arrival at the testing laboratory all samples will maintain the same vertical orientation. The Shelby tube shall be cut in approximate 6-inch lengths. Stiff soils (i.e., N_{60} -value greater than or equal to 9 blows per foot) shall be extruded in the same direction as the sample was pushed i.e., extrude the sample toward the top of the tube. For soft soils (i.e., N_{60} -value less than 9 blows per foot) cut the Shelby tube in approximate 6-inch lengths and very carefully cut the Shelby tube off the sample using something similar to a Dremel[®] tool. Prise the cut tube carefully off the sample to minimize disturbance. At no time shall the sample be extruded from the Shelby tube, since this may potentially disturb the sample. Prepare an Undisturbed Shelby Tube log as indicated in Chapter 6. Provide the Undisturbed Shelby Tube log to the GEOR prior to commencing any strength or consolidation testing. Based on the results of the log, the GEOR will determine which individual specimens will be used in testing.

The GEOR may request that the tube be x-rayed, prior to cutting any undisturbed sample in accordance with ASTM D4452 – *Standard Practice for X-Ray Radiography of Soil Samples*. The use of x-rays allows for the GEOR to evaluate soil features and disturbances and select where the tube needs to be cut. It is incumbent for the GEOR to understand the requirements and limitations as set forth in ASTM D4452. In addition, the GEOR is also responsible to ascertain whether the GEC has the equipment and expertise to perform such an x-ray test.

5.4.6 Strength Tests

The shear strength is the internal resistance per unit area that the soil can handle before failure and is expressed as a stress. There are 2 components of shear strength, a cohesive element (expressed as the cohesion, c , in units of force/unit area) and a frictional element (expressed as the angle of internal friction, ϕ in units of degrees, $^\circ$). These parameters are expressed in the form of total stress (c, ϕ) or effective stress (c', ϕ'). The total stress on any subsurface element is produced by the overburden pressure plus any applied loads. The effective stress equals the total stress minus the pore water pressure. The common methods of ascertaining these parameters in the laboratory are discussed below. All of these tests are normally performed on undisturbed samples, but may also be performed on remolded samples. Further, the moisture-plasticity (Atterberg Limits), moisture content, and grain-size analysis with wash #200 sieve shall be performed on all samples that are tested for shear strength.

5.4.6.1 Unconfined Compression Tests

The unconfined compression test is a quick method of determining the value of undrained strength $((S_u)_{UC}$ or $(\tau_{max})_{UC}$) for clay soils. The test involves a clay specimen with no confining pressure and an axial load being applied to observe the axial strains corresponding to various stress levels. The stress at failure is referred to as the unconfined compression strength, q_u . If failure has not occurred prior to 15 percent strain, then the sample at 15 percent strain is considered to have failed and the stress at this strain shall be reported as q_u . See ASTM D2166 - *Standard Test Method for Unconfined Compressive Strength of Cohesive Soil* (AASHTO T208 - *Standard Method of Test for Unconfined Compressive Strength of Cohesive Soil*).

$$(\tau_{max})_{UC} = (S_u)_{UC} = \left(\frac{q_u}{2}\right) \quad \text{Equation 5-5}$$

5.4.6.2 Triaxial Compression Tests

The triaxial compression test is a more sophisticated testing procedure, as compared to the unconfined compression test, for determining the shear strength of a soil. The test involves a soil specimen subjected to an axial load until failure while also being subjected to confining pressure that approximates the in-situ stress conditions. The GEOR shall be responsible for determining the required confining pressures (σ_3). The confining pressures shall model the existing loading conditions on the soil as well as future loading conditions. There are 3 types of triaxial tests which are described below.

5.4.6.2.1 Unconsolidated-Undrained (UU), or Q Test

In unconsolidated-undrained (UU) tests, the specimen is not permitted to change its initial water content before or during shear (i.e., the volume of the sample doesn't change). It should be noted that the results of this test are predicated on the assumption that the soil sample is 100 percent saturated. Typically, a UU test is performed on samples that will mechanically behave as a Clay-Like soil (see Chapter 7 for an explanation of Clay-Like). The results are expressed in total stress parameters, $(S_u)_{UU}$ (see Figure 5-13; where each test is considered independent of the other tests). In addition to $(S_u)_{UU}$, the σ_3 for each undrained shear strength shall be indicated. The σ_3 should range from the existing overburden pressure to the anticipated full embankment height. The interpretation of c and ϕ from an UU test is incorrect and shall not be accepted. The failure mode of the soil specimen shall also be indicated (i.e., bulging, shear plain, etc.). This test is used primarily in the calculation of immediate embankment stability during quick-loading conditions. Refer to ASTM D2850 - *Standard Test Method for Unconsolidated-Undrained Triaxial Compression Test on Cohesive Soils* (AASHTO T296 - *Standard Method of Test for Unconsolidated, Undrained Compressive Strength of Cohesive Soils in Triaxial Compression*).

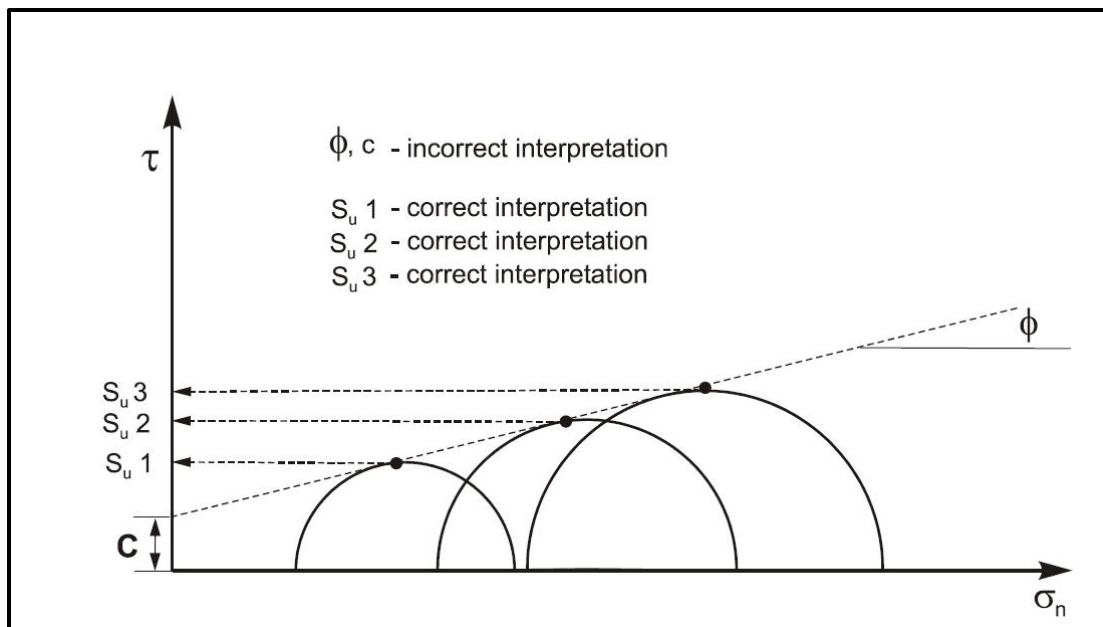

**Figure 5-13, Interpretation of UU Test Data
(Sabatini et al. (2002))**

5.4.6.2.2 Consolidated-Undrained (CU), or R Test

The consolidated-undrained (CU) test is the most common type of triaxial test. This test allows the soil specimen to be isotropically consolidated under a confining (also called consolidation) pressure (σ_3 or σ_c) prior to shear. In some of the literature this test is also designated CIU (consolidated isotropic undrained) shear strength test. When pore pressures are also measured during testing, the test is designated CUw/pp (CIUw/pp), both effective and total stress soil shear strength parameters may be developed. Therefore, CU tests with pore pressure measurements (CUw/pp) are required on SCDOT projects. As presented below, when selecting σ_3 for use in testing to account for the effects of sample disturbance. Effective stress parameters, ϕ' and c' , for soils that behave mechanically as a Clay-Like soil (see Chapter 7 for an explanation of Clay-Like) can be directly developed from the results of the testing and used in long-term stability analyses. For the same soil type, short-term stability analyses should be performed using total stress parameters, ϕ and c . The total stress parameters, ϕ and c , should only be used when the amount of consolidation settlement is less than 3 inches or the site has been determined to be overconsolidated ($OCR \geq 4$). Do not use ϕ and c prior to consolidation of the subsurface soils. Instead use S_u as determined using the procedure recommend by Duncan, Wright and Brandon (2014) and depicted in Figure 5-14. Where each S_u is determined for a specific confining stress (σ'_3) and is used at a depth corresponding to the confining stress.

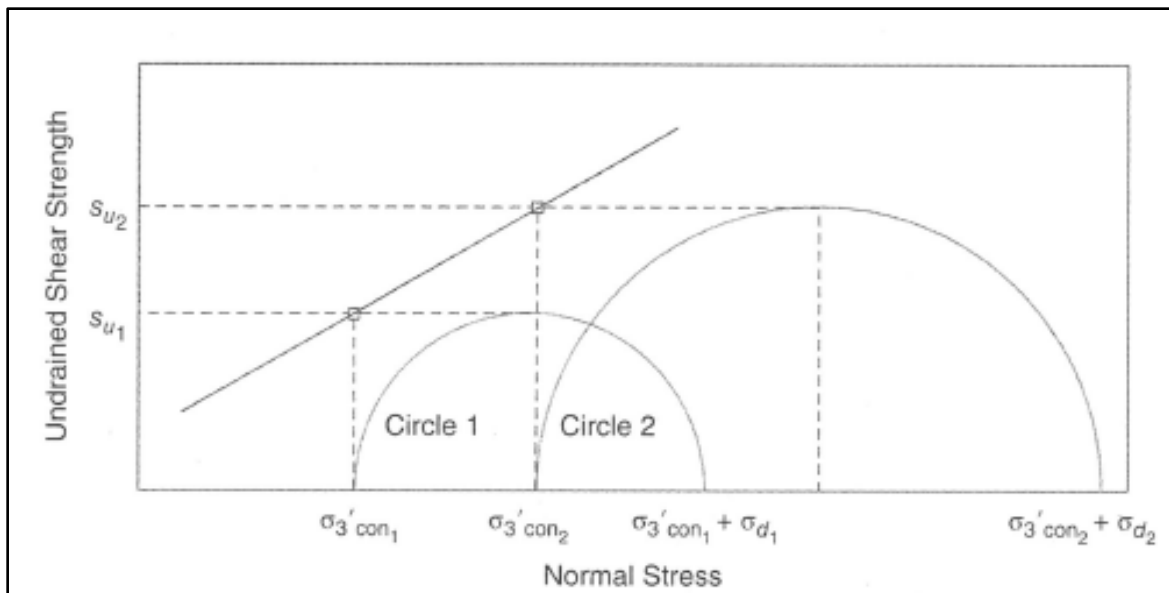

**Figure 5-14, Interpretation of CU Test Data
(Duncan, Wright and Brandon (2014))**

In the total stress analyses the ratio of the undrained shear strength ($(S_u)_{CU}$) to effective overburden pressure (σ'_v) or in the case of laboratory testing σ'_3 ; $(S_u)_{CU}/\sigma'_v$ or $((S_u)_{CU})/\sigma'_3$ should be used. It is noted that in this approach to total stress analyses, it is assumed that $\phi = 0$.

Where,

ϕ = Total stress friction angle

σ'_3 = Effective confining pressure

$$\sigma'_3 = \sigma_3 - \Delta u \quad \text{Equation 5-6}$$

Where:

σ_3 = Total confining pressure

Δu = Change in pore pressure

According to Sabatini et al. (2002), a confining pressure (σ_3) approximately equal to the in-situ effective overburden stress (σ'_{vo}) will overestimate the undrained shear strength of the soil. This overestimation of undrained shear strength is caused by sample disturbance. During drilling, sampling, transportation, extrusion and sample trimming the sample will become denser (i.e., the void ratio, e , will decrease). When confined at the same approximate overburden pressure, the denser sample will tend to have higher shear strength than the actual soil would have. To compensate for this apparent overestimation of undrained shear strength, the use of a confining stress in excess of the effective overburden stress should be used.

To compensate for this overestimation of undrained shear strength, the undrained shear strength should be normalized by the confining pressure (σ'_3) as discussed previously. This will develop the Normalized Strength Ratio (NSR) for the soil. To determine the in-situ shear strength at a specific depth without disturbance, multiply the NSR by the effective overburden pressure (σ'_{vo}). This procedure works for normally consolidated soils. To use this approach in overconsolidated

soils, the OCR first needs to be determined. The same procedure can be used as for normally consolidated soils as long as the confining pressure (σ'_3) is higher than the past consolidation pressure. This will cause the soil sample to become normally consolidated.

The results of the CUw/pp testing shall include the following information and graphs:

1. Mohr's Circle (total stress) including undrained shear strength at failure
 - a. $((S_u)_{UC}) / \sigma'_{vo}$ or $((S_u)_{UC}) / \sigma'_3$
2. Mohr's Circle (effective stress) including best fit line – see Figure 5-15
 - a. ϕ'
 - b. c'
3. p' - q' plots (effective stress) – see Figure 5-16
 - a. α'
 - b. a'
4. p - q plots (total stress) including undrained shear strength at failure
 - a. $((S_u)_{UC}) / \sigma'_{vo}$ or $((S_u)_{UC}) / \sigma'_3$

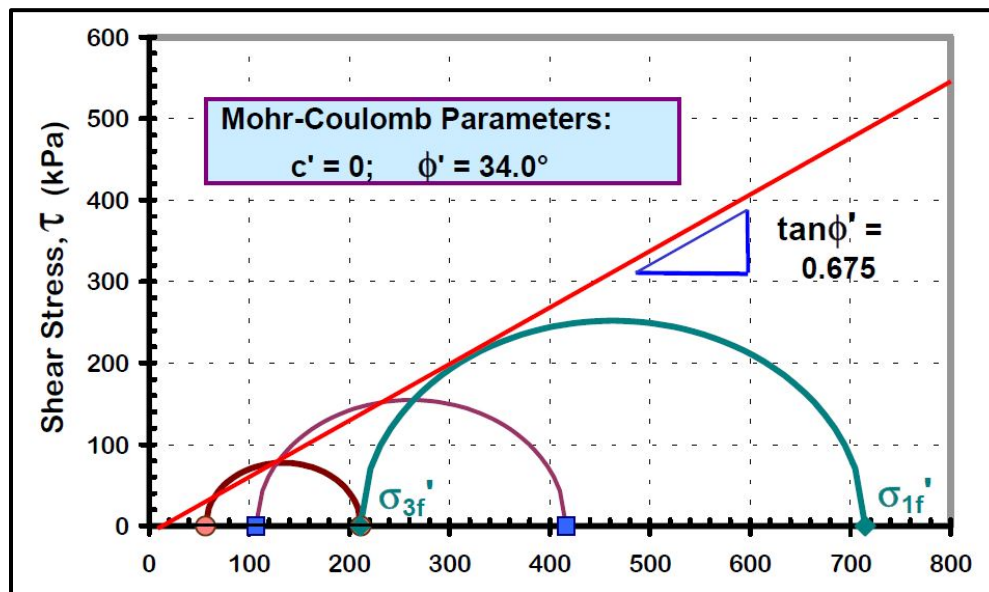
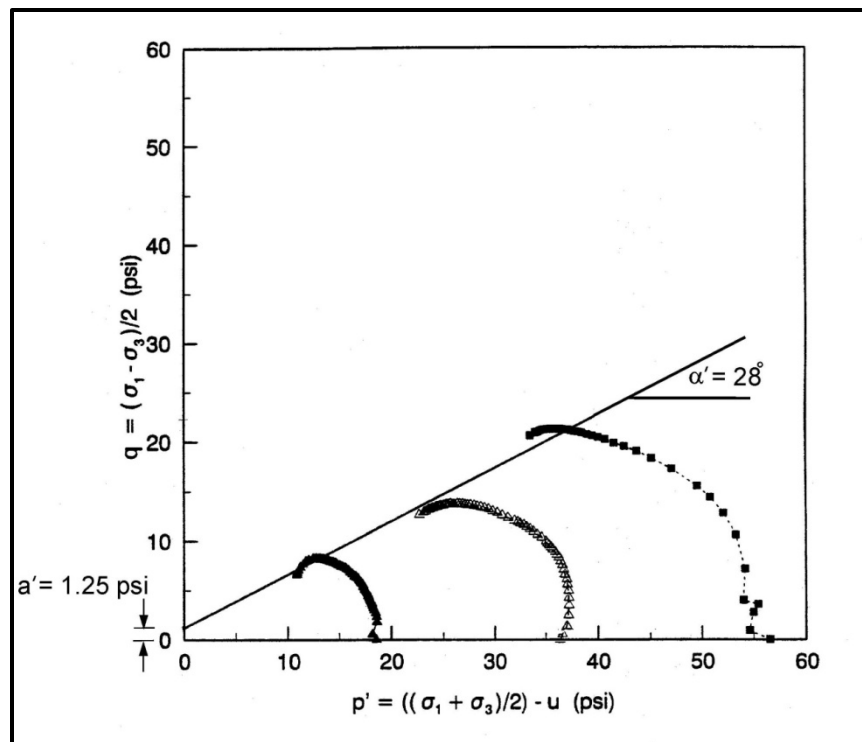

Figure 5-15, Mohr Circle Depicting Mohr-Coulomb Failure Criterion (Mayne et al. (2002))



**Figure 5-16, Stress Path (p' - q') Plot
(Sabatini et al. (2002))**

Effective stress soil parameters (ϕ' and c') can be derived from the stress path plot using the following equations:

$$\phi' = \sin^{-1} \tan \alpha' \quad \text{Equation 5-7}$$

$$c' = \frac{a'}{\cos \phi'} \quad \text{Equation 5-8}$$

The failure mode of the soil specimen shall also be indicated (i.e., bulging, shear plain, etc.). In addition, the procedure for determining failure shall also be indicated. See ASTM D4767 - *Standard Test Method for Consolidated Undrained Triaxial Compression Test for Cohesive Soils* (AASHTO T297 - *Standard Method of Test for Consolidated, Undrained Triaxial Compression Test on Cohesive Soils*).

5.4.6.2.3 Consolidated-Drained (CD), or S Test

The consolidated-drained (CD) test is similar to the consolidated-undrained test except that drainage is permitted during shear and the rate of shear is very slow. Thus, the buildup of excess pore pressure is prevented. Because of the length of time to conduct this test, it is typically not performed on SCDOT projects. The exception to this is if the sample is Sand-Like (see Chapter 7 for an explanation of Sand-Like) then a consolidated-drained triaxial shear test may be considered. Prior to performing this test, the RPG/GDS and OES/GDS shall review the purpose of the test and the anticipated outcome. This test is used to determine parameters for calculating long-term stability of embankments. The failure mode of the soil specimen shall also be indicated (i.e., bulging, shear plain, etc.). In addition, the procedure for determining failure shall also be

indicated. Refer to ASTM D7181 – *Standard Test Method for Consolidated Drained Triaxial Compression Test for Soils*.

5.4.6.3 Resonant-Column Test

The resonant-column test is used to determine the shear modulus, G ; shear damping, λ ; and Young's modulus, E . This test may be performed on either undisturbed or remolded specimens. In addition, the specimen may be unconfined or the specimen may have a confining pressure applied to it. If confining pressure is to be used the procedures discussed in Section 5.4.5.2.1 shall be used in regards the confining pressure. The GEOR shall be responsible for determining the required σ_3 . See ASTM D4015 – *Standard Test Methods for Modulus and Damping of Soils by Resonant-Column Method*.

5.4.6.4 Direct Shear

The direct shear test is the oldest and simplest form of shear test. A soil sample is placed in a metal shear box and undergoes a horizontal force, typically designated T (tangential force). While the horizontal force is being applied, a normal force (N (P in Figure 5-16)) is applied to the top of the direct shear box. The application of a higher N causes T to increase. The forces are often expressed as stresses (σ_N and τ). Because of the way the shear test is conducted, the soil fails along a horizontal plane. The test is performed using strain-control and is performed slowly enough to allow drainage to prevent the buildup of excess pore pressures. There are 2 types of direct shear test; simple and torsional, each test is described in the following Sub-sections. Similarly, to the triaxial tests, the GEOR shall be responsible for determining N for both test types.

5.4.6.4.1 Direct Simple Shear Test

The direct simple shear test is applicable to all soil types; however, it is typically performed on Sand-Like (see Chapter 7 for an explanation of Sand-Like). The results of the test shall be presented as indicated in Figure 5-17. In addition, a table of σ_N and τ shall also be provided.

The test is typically performed as consolidated-drained test on Sand-Like soils; however, there is a test method available to perform a consolidated-undrained test, ASTM D6528 – *Standard Test Method for Consolidated Undrained Direct Simple Shear Testing of Cohesive Soils*. The use of ASTM D6528 will require approval by the OES/GDS. See ASTM D3080 - *Standard Test Method for Direct Shear Test of Soils Under Consolidated Drained Conditions* (AASHTO T236 - *Standard Method of Test for Direct Shear Test of Soils Under Consolidated Drained Conditions*).

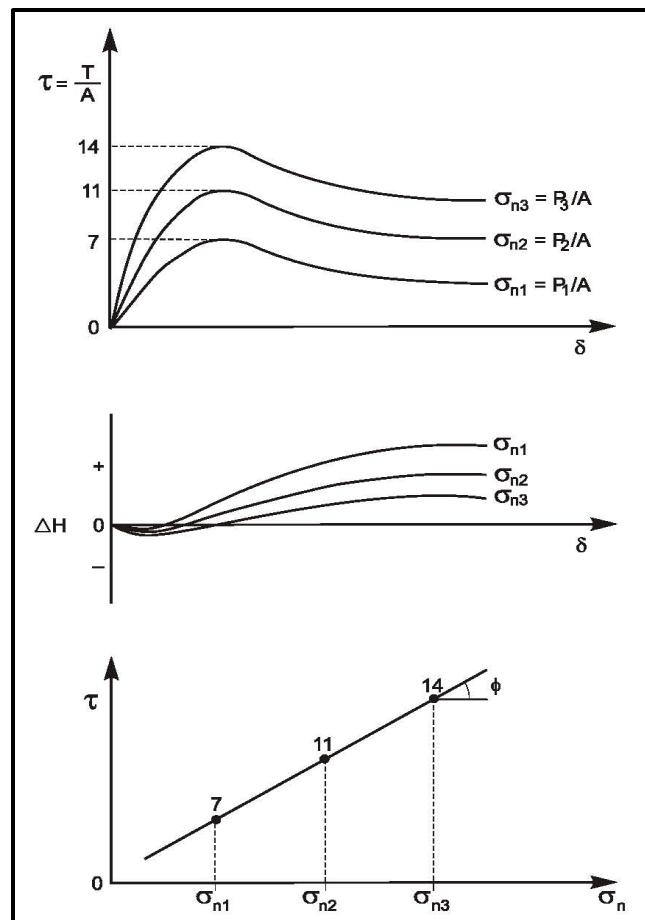

**Figure 5-17, Direct Shear Test Results
(Sabatini et al. (2002))**

5.4.6.4.2 Torsional Ring Shear Test

According to Terzaghi, Peck and Mesri (1996), triaxial and direct simple shear testing "...lack the ability to investigate the shearing resistance of soils at very large strains or displacements;...". Therefore, to account for the application of very large strains the torsional ring shear test device was developed by a joint effort of the Norwegian Geotechnical Institute and Imperial College (Terzaghi, Peck and Mesri (1996)). This test method should not be used on Sand-Like soils (see Chapter 7 for an explanation of Sand-Like soils). Torsional shear testing should be used on Clay-Like soils (see Chapter 7 for an explanation of Clay-Like). There are 2 testing methods, ASTM D6467 – *Standard Test Method for Torsional Ring Shear Test to Determine Drained Residual Shear Strength of Cohesive Soils* and ASTM D7608 – *Standard Test Method for Torsional Ring Shear Test to Determine Drained Fully Softened Shear Strength and Nonlinear Strength Envelope of Cohesive Soils (Using Normally Consolidated Specimen) for Slopes with No Preexisting Shear Surface*. The GEOR shall determine which test method is to be used based on the project requirements.

5.4.6.5 Miniature Vane Shear (Torvane) and Pocket Penetrometer

The miniature vane shear and the pocket penetrometer tests are performed to obtain undrained shear strength ($(S_u)_{tv}$ or $(S_u)_{pp}$, respectively) for plastic cohesive soils. Both of these tests consist of hand-held devices that are pushed into the sample and either a torque resistance (Torvane) or

a tip resistance (pocket penetrometer) is measured. They can be performed in the lab or in the field. See ASTM D4648 - *Standard Test Method for Laboratory Miniature Vane Shear Test for Saturated Fine-Grained Clayey Soil* for the miniature vane shear test only.

5.4.7 Consolidation Test

The amount of settlement (S_t or Δ_v) induced by the placement of load bearing elements (i.e., ERSs or bridges) on the ground surface or the construction of earthen embankments will affect the performance of a structure. The amount of settlement is a function of the increase in pore water pressure caused by the loading and the reduction of this pressure over time. The reduction in pore pressure and the rate of the reduction are a function of the permeability of the in-situ soil. All soils undergo elastic compression (S_i), primary consolidation (S_c) and secondary compression (S_s). Sand-Like soils tend to be relatively permeable and will therefore, undergo settlement much faster. The amount of elastic compression settlement can vary depending on the soil type; however, the time for this settlement to occur is relatively quick and will normally occur during construction.

Clay-Like soils tend have a much lower permeability and will, therefore, take longer to settle. Clay-Like soils undergo elastic compression during the initial stages of loading (i.e., the soil particles rearrange due to the loading and/or any air pockets are squeezed closed and the soil becomes saturated). After elastic compression of Clay-Like soils is complete, primary consolidation begins. Saturated Clay-Like soils have a lower coefficient of permeability, thus the excess pore water pressure generated by loading will gradually dissipate over a longer period of time. Therefore in saturated clays, the amount and rate of settlement is of great importance in construction. For example, an embankment may settle until a gap exists between an approach and a bridge abutment. The calculation of settlement involves many factors, including the magnitude of the load, the effect of the load at the depth at which compressible soils exist, the water table, and characteristics of the soil itself. Consolidation testing is performed to ascertain the nature of these characteristics. The most commonly used test procedure is the incremental load method of 1-dimensional consolidation testing. See ASTM D2435 - *Standard Test Methods for One-Dimensional Consolidation Properties of Soils Using Incremental Loading* (AASHTO T216 - *Standard Method of Test for One-Dimensional Consolidation Properties of Soils*). In addition, the moisture-plasticity (Atterberg Limits), moisture content, grain-size analysis with wash #200 sieve and specific gravity shall be performed on all samples tested using this test method. ASTM D4186 – *Standard Test Method for One-Dimensional Consolidation Properties of Saturated Cohesive Soils Using Controlled Strain Loading* shall not be allowed.

The consolidation test unit consists of a consolidometer (or alternatively, an oedometer) and a loading device. The soil sample is placed between 2 porous stones, which permit drainage (i.e., double drainage). Load is applied incrementally and is typically held up to 24 hours. The loading increments shall be determined by the GEOR. The GEOR shall review the results of each load increment (i.e., e versus log time plots (see Figure 5-18), alternatively ε versus log time plots may be used) to determine if the load has been held a sufficient length of time to determine the secondary compression (c_α) index. The next load increment shall only be applied as approved by the GEOR. The secondary compression index shall be determined as indicated in the following paragraphs. The test measures the change in height (strain) of the specimen after each loading is applied. In addition, the GEOR shall determine if an unload/reload cycle is to be included and at which load increment the cycle shall begin and end. Typically the unload/reload cycle should begin when the loading exceeds the preconsolidation pressure (σ'_p) by at least 1 loading increment. A first-order estimate of the σ'_p shall be made using the correlations provided in

Chapter 7. Further, the consolidation testing shall extend to loads of 8 times the first-order estimate of σ'_p . After the maximum loading has been reached, the loading is removed in appropriate decrements. Contact the RPG/GDS and the OES/GDS for guidance if the anticipated range of loading exceeds the load limits of the testing apparatus. It is noted that a consolidation test with unload/reload cycle should require between 14 and 16 loading increments to form a complete test. The 1-dimensional consolidation test is used to determine the parameters for use in 1-dimensional consolidation theory. These parameters are indicated in Table 5-2.

Table 5-2, Consolidation Parameters and Symbols

Symbol	Parameter
C_c or $C_{\varepsilon c}$	Compression Index
C_r or $C_{\varepsilon r}$	Recompression Index
C_{α} or $C_{\varepsilon \alpha}$	Secondary Compression Index
σ'_p or p'_c	Effective Preconsolidation Stress
c_v	Coefficient of Consolidation
m_v	Coefficient of Vertical Compression

The results of each load increment are plotted on a deformation (void ratio) versus log time plot (see Figure 5-18). Alternatively, the strain versus log time plot may be used. From this curve, 2 parameters can be derived: coefficient of consolidation (c_v) and secondary compression (C_{α}) index. These parameters are used to predict the rate of primary settlement and the amount of secondary consolidation. Further this curve is used to determine when primary consolidation is complete for each load increment.

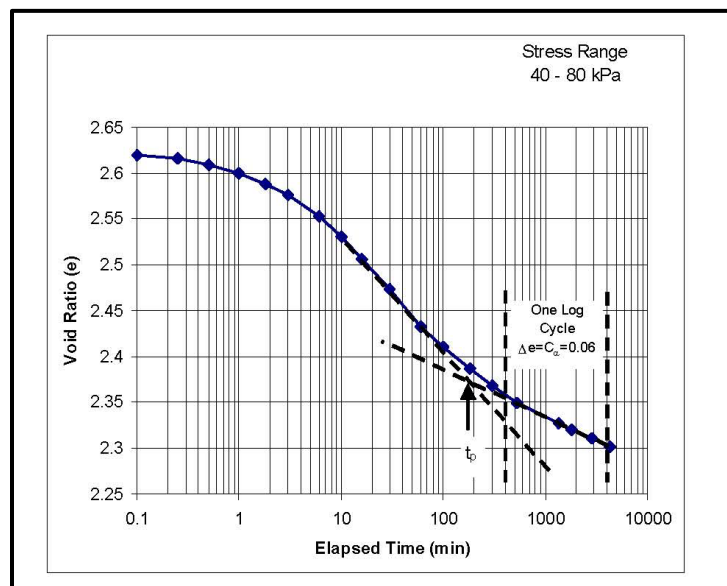

t_p = time to 100 percent consolidation (i.e., end of primary consolidation)

**Figure 5-18, Void Ratio versus log Time
(Sabatini et al. (2002))**

The coefficient of consolidation (c_v) shall be determined using both Casagrande's logarithm of time and Taylor's square root of time method. Casagrande's method uses the time to 50 percent of primary consolidation and Taylor's method use the time to 90 percent of primary consolidation and determines c_v using:

$$c_v = \frac{0.197 * H_{DR}^2}{t_{50}} \quad \text{Equation 5-9}$$

$$c_v = \frac{0.848 * H_{DR}^2}{t_{90}} \quad \text{Equation 5-10}$$

Where,

H_{DR} – Height of the drainage path (assumed to be $\frac{1}{2}$ of specimen thickness at each load increment to account for double drainage), inches

t_{50} – Time required to achieve 50 percent primary consolidation, seconds

t_{90} – Time required to achieve 90 percent primary consolidation, seconds

It is noted that both Casagrande's and Taylor's methods are included in the ASTM and shall be used to determine c_v for each load increment. Both sets of c_v shall be plotted and provided to the GEOR. The c_v , typically is higher for load increments under σ'_p and lower when the load increments are over the σ'_p .

After the time-deformation plots are obtained, the void ratio and the strain can be calculated. Two more plots can be presented; an e-log p curve, which plots void ratio (e) as a function of the log of pressure (p), or an ε -log p curve where ε equals percent strain. The parameters necessary for settlement calculation can be derived from the corrected e-log p curve and are: compression index (C_c), recompression index (C_r), preconsolidation pressure (σ'_p), and initial void ratio (e_o). Alternatively, the corrected ε -log p curve provides the compression index ($C_{\varepsilon c}$), the recompression index ($C_{\varepsilon r}$), and the preconsolidation pressure (σ'_p). The 1-dimensional consolidation test is sensitive to sample disturbance; therefore, the results of the test must be corrected, by the GEOR, using the procedures provided in Chapter 7.

Casagrande (1936) developed a graphical procedure for determining the preconsolidation stress. The Casagrande procedure for determining preconsolidation stress is outlined in Table 5-3. While the Casagrande procedure was applicable to both e-log p and ε -log p curves, SCDOT prefers the use of the ε -log p curve for data presentation. The effective preconsolidation stress (σ'_p) is extremely important because it is used to determine if a soil is normally consolidated (NC) or overconsolidated (OC). In normally consolidated soils, the effective preconsolidation stress is equal to the existing effective overburden stress (i.e., $\sigma'_{vo} = \sigma'_p$) (see Figure 5-18). Normally consolidated soils tend to have large settlements. Overconsolidated soils have an effective preconsolidation stress greater than the existing effective overburden stress (i.e., $\sigma'_{vo} < \sigma'_p$) (see Figure 5-19). Overconsolidated soils do not tend to have large settlements. In some locations within South Carolina, under consolidated soils (i.e., $\sigma'_{vo} > \sigma'_p$) (see Figure 5-20) are known to exist. These soils are still consolidating under the weight of the soil and should be anticipated to have very large amounts of settlement.

**Table 5-3, Determination of Preconsolidation Stress
(Duncan and Buchignani (1976))**

Step	Description
1	Locate the point of sharpest curvature on the e-log p or ϵ -log p curve
2	From this point (a) (see Figures 5-22 or 5-23), draw a horizontal line (b) and a tangent (b) to the curve
3	Bisect the angle formed by these 2 lines (c)
4	Extend the virgin curve (d) backward to intersect the bisector (c)
5	The point where these lines (d and c) cross determines the preconsolidation pressure (σ'_p or p'_c)

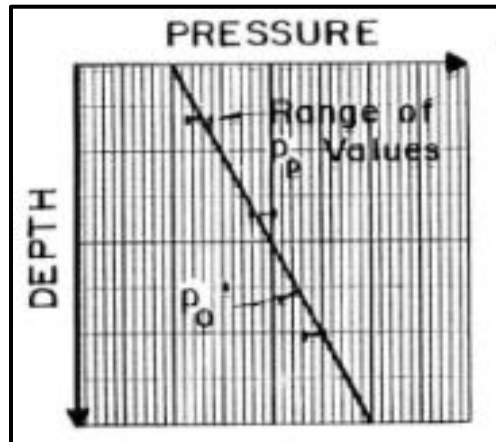

**Figure 5-19, Normally Consolidated
(Duncan and Buchignani (1976))**

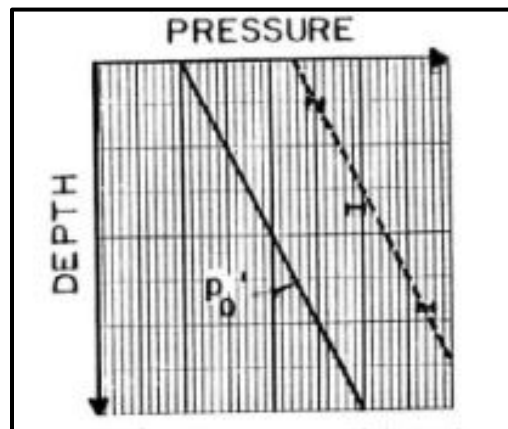

**Figure 5-20, Overconsolidated
(Duncan and Buchignani (1976))**

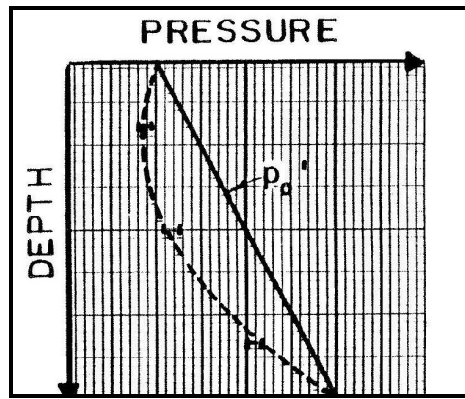

Figure 5-21, Under Consolidated (Duncan and Buchignani (1976))

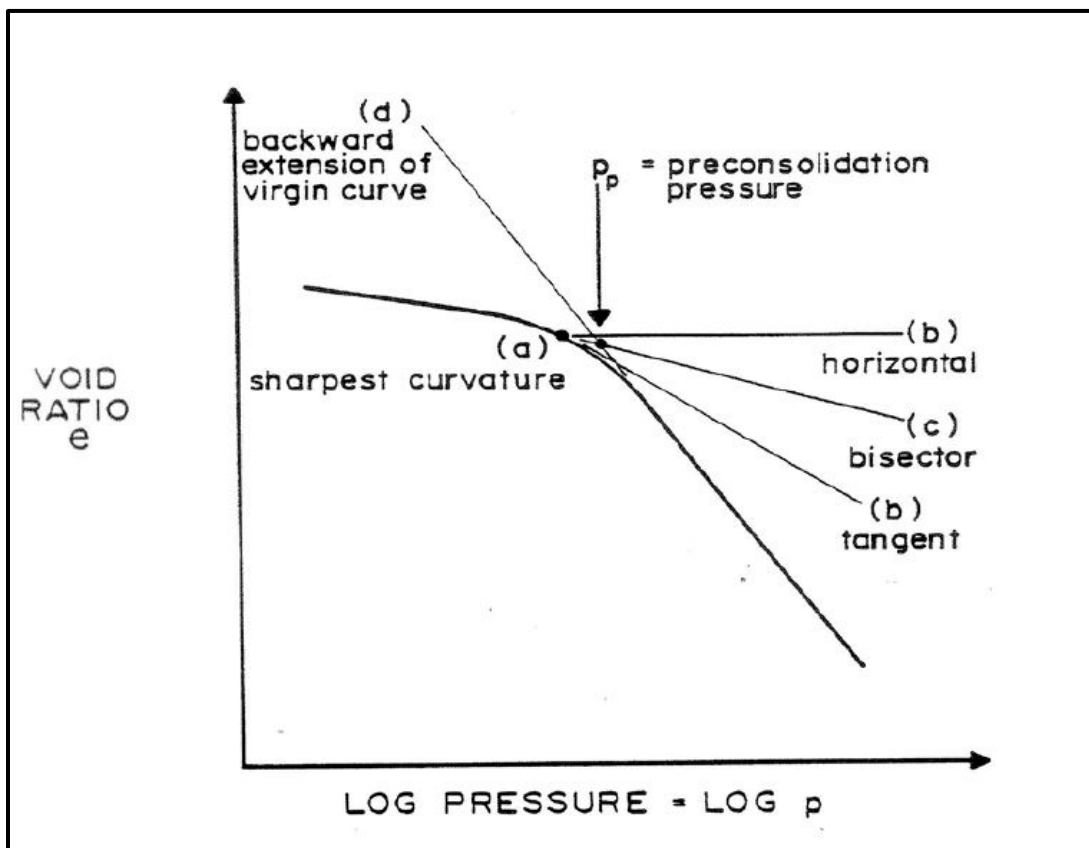
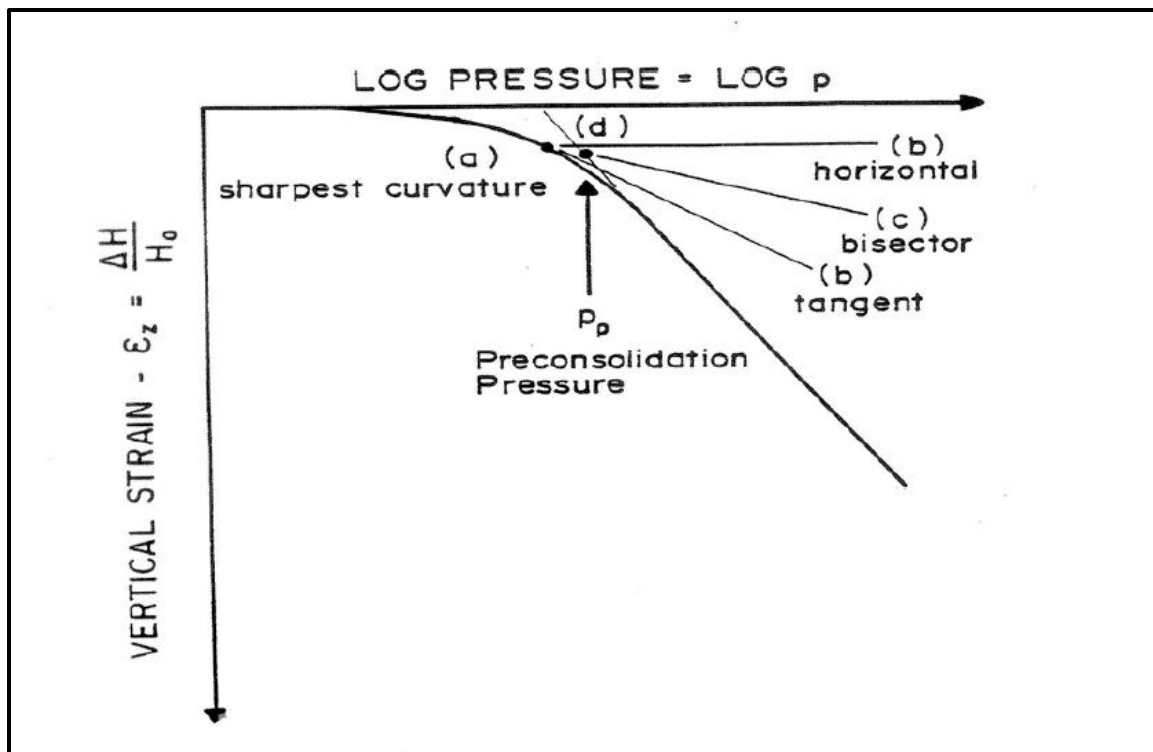

Figure 5-22, Determination of Preconsolidation Stress from e-log p (Duncan and Buchignani (1976))



**Figure 5-23, Determination of Preconsolidation Stress from ϵ -log p
(Duncan and Buchignani (1976))**

In addition to using the Casagrande reconstruction method to determine σ'_p , the Strain-Energy method (Becker, Crooks, Been and Jefferies (1987)) shall also be used. The Strain-Energy method involves plotting the cumulative strain energy (i.e., the product of stress times strain) for each load increment in a laboratory consolidation test. The point where the strain energy plot exhibits a large incremental increase represents the preconsolidation stress, σ'_p , for the soil. The first step in determining σ'_p using the Strain-Energy method is determining the change in work (energy) per unit volume using the following equation:

$$\Delta W = \left[\frac{(\sigma'_i + \sigma'_f)}{2} \right] * (\epsilon_f - \epsilon_i) \quad \text{Equation 5-11}$$

Where,

ΔW = Change in work (energy) per unit volume (units of stress (tsf (kJ/m³ or kPa)))

σ'_i = Stress at beginning of strain increment (units of stress (tsf))

σ'_f = Stress at end of strain increment (units of stress (tsf))

ϵ_i = Strain at beginning of increment (dimensionless)

ϵ_f = Strain at end of increment (dimensionless)

The second step is to plot the stress versus the summation of work for each stress increment (see Figure 5-24). It is assumed that the stress value corresponding to the summation of work is the stress at the end of the strain increment. A noticeable change in slope should be evident when the data are plotted. A curve connecting the data should have a sharp transition from a flatter slope in the recompression range (slope 1) to a steeper slope (slope 2) in the virgin compression range. Construct a trend line through the data that represent a line with slope 1. Construct a

second trend line through the data that represent a line with slope 2. The stress where these 2 trend lines intersect is the preconsolidation stress, σ'_p .

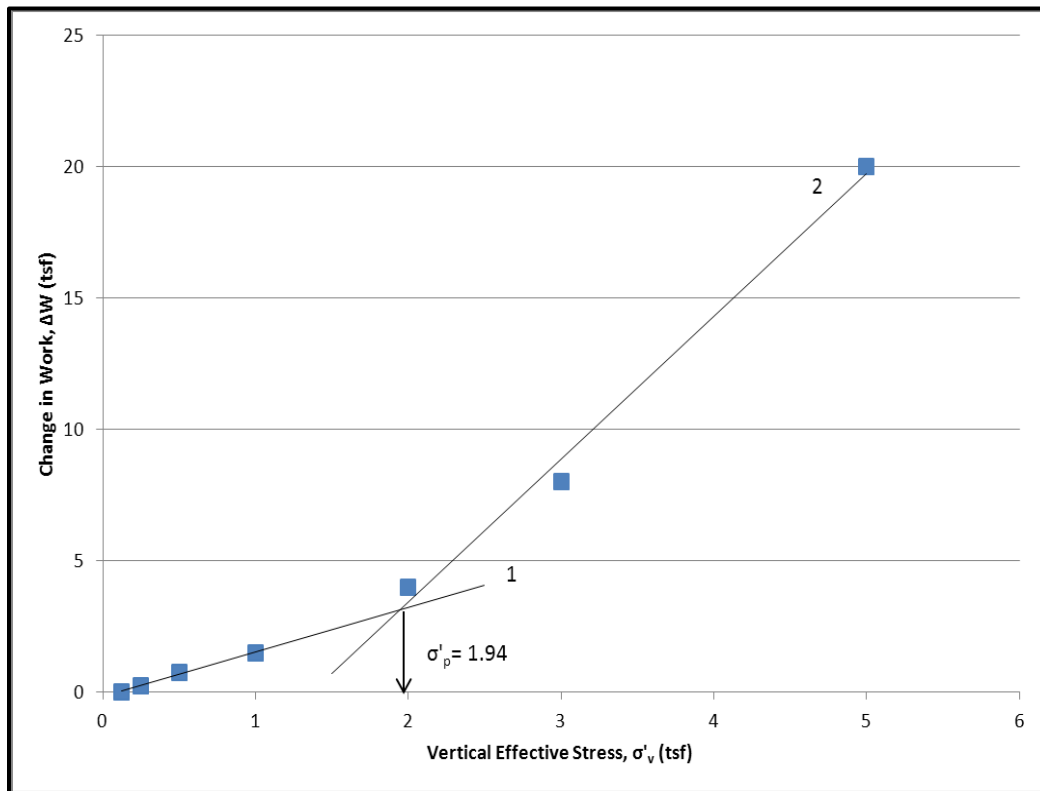

**Figure 5-24, Change in Work vs. Vertical Effective Stress
(Sabatini et al. (2002))**

The preconsolidation stress, σ'_p , determined from both the Casagrande reconstruction method and from the Strain-Energy method shall be provided. In addition, all results provided shall be indicated as being uncorrected.

The secondary compression (C_{α} or $C_{\varepsilon\alpha}$) index shall be determined for each loading increment and shall be reported graphically similarly to the coefficient of consolidation (c_v) versus the log of pressure. Secondary compression settlement begins at the completion of primary consolidation and in certain soils including highly organic soils secondary compression settlement can exceed the amount of settlement caused by consolidation. The secondary compression index is determined from the void ratio (C_{α}) (strain ($C_{\varepsilon\alpha}$)) versus log time graph (see Figure 5-18) and is determined using the following equations:

$$C_{\alpha} = \frac{e_2 - e_1}{\log\left(\frac{t_2}{t_1}\right)} \quad \text{Equation 5-12}$$

$$C_{\varepsilon\alpha} = \frac{\varepsilon_2 - \varepsilon_1}{\log\left(\frac{t_2}{t_1}\right)} \quad \text{Equation 5-13}$$

Where:

e_2 = Void ratio at time 2

e_1 = Void ratio at time 1

ε_2 = Strain at time 2

ε_1 = Strain at time 1

t_1 and t_2 = Time that occurs after the time to end primary consolidation, seconds

For highly organic materials (organic content greater than 50%), research sponsored by the Florida Department of Transportation has shown that the end of primary consolidation occurs quickly in the laboratory and field, and that a major portion of the total settlement is due to secondary compression (creep). As a result, differentiating between primary consolidation and secondary compression settlement can be very difficult and generate misleading results. To analyze results from 1-dimensional consolidation tests for these types of materials, use the Square Root (Taylor) Method to identify the end of primary consolidation for each load sequence. In addition, each load sequence must be maintained for at least 24 hours to identify a slope for the secondary consolidation portion of the settlement versus time plot.

5.4.8 Organic Content

Organic soils demonstrate very poor engineering characteristics, most notably low strength and high compressibility. In the field these soils can usually be identified by their dark color, musty odor and low unit weight. The most used laboratory test for quantification purposes is the Ignition Loss test, which measures how much of a sample's mass burns off when placed in a muffle furnace. The results are presented as a percentage of the total sample mass. Tests shall be performed in accordance with ASTM D2974 - *Standard Test Methods for Moisture, Ash, and Organic Matter of Peat and Other Organic Soils* (AASHTO T267 - *Standard Method of Test for Determination of Organic Content in Soils by Loss on Ignition*).

5.4.9 Shrinkage and Swell

Certain soil types (highly plastic) have a large potential for volumetric change depending on the moisture content of the soil. These soils can shrink with decreasing moisture or swell with increasing moisture. Shrinkage can cause soil to pull away from structure thus reducing the bearing area or causing settlement of the structure beyond that predicted by settlement analysis. Swelling of the soil can cause an extra load to be applied to the structure that was not accounted for in design. Therefore, the potential for shrinkage and swelling should be determined for soils that have high plasticity.

5.4.9.1 Shrinkage

These tests are performed to determine the limits of a soil's tendency to lose volume during decreases in moisture content. The shrinkage limit (SL) is presented as a percentage in moisture content, at which the volume of the soil mass ceases to change. See ASTM D4943 – *Standard Test Method for Shrinkage Factors of Soils by the Wax Method* (AASHTO T92 - *Standard Method of Test for Determining the Shrinkage Factors of Soils*).

5.4.9.2 Swell

There are certain types of soils that can swell, particularly clay in the montmorillonite family. Swelling occurs when the moisture is allowed to increase causing the clay soil to increase in volume. There are a number of reasons for this to occur: the elastic rebound of the soil grains, the attraction of the clay mineral for water, the electrical repulsion of the clay particles and their

adsorbed cations from one another, or the expansion of the air trapped in the soil voids. In the montmorillonite family, adsorption and repulsion predominate and this can cause swelling. Testing for swelling is difficult, but can be done. It is recommended that these soils not be used for roadway construction. The swell potential can be estimated from the test methods shown in AASHTO T258 - *Standard Method of Test for Determining Expansive Soils*.

5.4.10 Permeability

Permeability, also known as hydraulic conductivity, has the same units as velocity and is generally expressed in ft/min or m/sec. The coefficient of permeability is dependent on void ratio, grain-size distribution, pore-size distribution, roughness of mineral particles, fluid viscosity, and degree of saturation. There are 3 standard laboratory test procedures for determining the coefficient of soil permeability, constant and falling head tests, and flexible wall test.

5.4.10.1 Constant Head Test

In the constant head test, water is poured into a sample of soil, and the difference of head between the inlet and outlet remains constant during the testing. After the flow of water becomes constant, water that is collected in a flask is measured in quantity over a time period. This test is more suitable for coarse-grained soils that have a higher coefficient of permeability. See AASHTO T215 - *Standard Method of Test for Permeability of Granular Soils (Constant Head)*.

5.4.10.2 Falling Head Test

The falling head test uses a similar procedure to the constant head test, but the head is not kept constant. The permeability is measured by the decrease in head over a specified time. This test is more appropriate for fine-grained soils. Tests shall be performed in accordance with ASTM D5856 - *Standard Test Method for Measurement of Hydraulic Conductivity of Porous Material Using a Rigid-Wall, Compaction-Mold Permeameter*.

5.4.10.3 Flexible Wall Permeability

For fine-grained soils, tests performed using a triaxial cell are generally preferred. In-situ conditions can be modeled by application of an appropriate confining pressure. The sample can be saturated using back pressuring techniques. Water is then allowed to flow through the sample and measurements are taken until steady-state conditions occur. Tests shall be performed in accordance with ASTM D5084 - *Standard Test Methods for Measurement of Hydraulic Conductivity of Saturated Porous Materials Using a Flexible Wall Permeameter*.

5.4.11 Compaction Tests

There are 2 types of tests that can be used to determine the optimum moisture content and maximum dry density of a soil (also termed the moisture-density relationship); the standard Proctor and the modified Proctor. The results of the tests are used to determine appropriate methods of field compaction and to provide a standard by which to judge the acceptability of field compaction.

The results of the compaction tests are typically plotted as dry density versus moisture content. Moisture content has a great influence on the degree of compaction achieved by a given type of soil. In addition to moisture content, there are other important factors that affect compaction. The

soil type has a great influence because of its various classifications, such as grain-size distribution, shape of the soil grains, specific gravity of soil solids, and amount and type of clay mineral present. The compaction energy also has an effect because it too has various conditions, such as number of blows, number of layers, weight of hammer, and height of the drop.

5.4.11.1 Standard Proctor

This test method uses a 5-1/2-pound rammer dropped from a height of 12 inches. The sample is compacted in 3 layers. See ASTM D698 - *Standard Test Methods for Laboratory Compaction Characteristics of Soil Using Standard Effort (12,400 ft-lbf/ft³ (600 kN-m/m³))* (AASHTO T99 - *Standard Method of Test for Moisture-Density Relations of Soils Using a 2.5-kg (5.5-lb) Rammer and a 305-mm (12-in.) Drop*).

5.4.11.2 Modified Proctor

This test method uses a 10-pound rammer dropped from a height of 18 inches. The sample is compacted in 5 layers. See ASTM D1557 - *Standard Test Methods for Laboratory Compaction Characteristics of Soil Using Modified Effort (56,000 ft-lbf/ft³ (2,700 kN-m/m³))* (AASHTO T180 - *Standard Method of Test for Moisture-Density Relations of Soils Using a 4.54-kg (10-lb) Rammer and a 457-mm (18-in.) Drop*).

5.4.12 Relative Density Tests

The relative density tests are most commonly used for granular or unstructured soils. It is used to indicate the in-situ denseness or looseness of the granular soil. In comparison, Proctor tests often do not produce a well-defined moisture-density curve for cohesionless, free-draining soils. Therefore relative density is expressed in terms of maximum and minimum possible dry unit weights and can be used to measure compaction in the field.

5.4.12.1 Maximum Index Density

In this test, soil is placed in a mold of known volume with a 2-psi surcharge load applied to it. The mold is then vertically vibrated at a specified frequency for a specified time. At the end of the vibrating period, the maximum index density can be calculated using the weight of the sand and the volume of the sand. See ASTM D4253 - *Standard Test Methods for Maximum Index Density and Unit Weight of Soils Using a Vibratory Table*.

5.4.12.2 Minimum Index Density

The test procedure requires sand being loosely poured into a mold at a designated height. The minimum index density can be calculated using the weight of the sand required to fill the mold and the volume of the mold. See ASTM D4254 - *Standard Test Methods for Minimum Index Density and Unit Weight of Soils and Calculation of Relative Density*.

5.4.13 Electro-Chemical Tests

Electro-chemical tests provide quantitative information related to the aggressiveness of the subsurface environment, the surface water environment, and the potential for deterioration of foundation materials. Electro-chemical testing includes pH, resistivity, sulfate, and chloride

contents. The electro-chemical tests shall be performed on soil samples. In addition, surface water shall also be tested in coastal regions where the potential intrusion of brackish (higher salinity) water may occur in tidal streams. All water (surface or subsurface) samples shall be obtained in accordance with sampling and chain-of-custody procedures prepared by the South Carolina Department of Health and Environmental Control (SCDHEC). In lieu of using ASTM or AASHTO testing procedures, testing procedures established by the US Environmental Protection Agency (EPA) may be used, provided the laboratory conducting the tests is certified to perform the test by either the EPA or SCDHEC. If EPA testing standards are used, the GEC shall be required to indicate which EPA standard was used and to provide proof that the laboratory performing the test is certified by either the EPA or SCDHEC.

5.4.13.1 pH Testing

pH testing is used to determine the acidity or alkalinity of the subsurface or surface water environments. Acidic or alkaline environments have the potential for being aggressive on structures placed within these environments. Soil samples collected during the normal course of a subsurface exploration should be used for pH testing. The pH of soils shall be determined ASTM G51 – *Standard Test Method for Measuring pH of Soil for Use in Corrosion Testing* (AASHTO T289 - *Standard Method of Test for Determining pH of Soil for Use in Corrosion Testing*). The surface water samples shall have the pH determined using ASTM D1293 – *Standard Test Methods for pH of Water*.

5.4.13.2 Resistivity Testing

Resistivity testing is used to determine the electric conduction potential of the subsurface environment. The ability of soil to conduct electricity can have a significant impact on the corrosion of steel components. If a soil has a high potential for conducting electricity, then sacrificial anodes may be required on the structure or the metal will need to be galvanized. This type of testing can be performed in the laboratory or in the field. For the field testing procedure see Section 5.3.10.6. Field resistivity measurements shall be determined using ASTM G57 – *Standard Test Method for Field Measurement of Soil Resistivity Using the Wenner Four-Electrode Method*. Laboratory resistivity shall be determined using either ASTM G57 (laboratory procedure) or AASHTO T288 – *Standard Method of Test for Determining Minimum Laboratory Soil Resistivity*. It is noted that AASHTO T288 will produce 2 resistivities, the first at 100 percent saturation and the second when the soil is in a slurry condition. Both testing results are to be reported with a designation as to the sample condition (i.e., 100 percent saturation or a slurry condition). The resistivity of surface water samples can be determined using ASTM D1125 – *Standard Test Methods for Electrical Conductivity and Resistivity of Water*.

5.4.13.3 Chloride Testing

Subsurface soils and surface water should be tested for chloride if the presence of sea or brackish water is suspected or if a source of groundwater contamination is known. Chloride testing for soils shall be determined using AASHTO T291 – *Standard Method of Test for Determining Water-Soluble Chloride Ion Content in Soil*. The chloride testing for the surface water shall be performed in accordance with ASTM D512 – *Standard Test Methods for Chloride Ion in Water*.

5.4.13.4 Sulfate Testing

Subsurface soils and surface water should be tested for sulfate, especially if a source of groundwater contamination is known to exist in the general vicinity of the project. Sulfate testing for soils shall be determined using ASTM C1580 – *Standard Test Method for Water-Soluble Sulfate in Soil* (AASHTO T290 – *Standard Method of Test for Determining Water-Soluble Sulfate Ion Content in Soil*). The sulfate testing for the surface water shall be performed in accordance with ASTM D516 – *Standard Test Method for Sulfate Ion in Water*.

5.4.14 Rock Cores

Rock coring, as indicated in Chapter 6, should begin when drilling refusal is encountered. At each core run, the length of the rock sample obtained and the distance the core run is drilled will give a recovery ratio. The recovery ratio is expressed in percentage with 100% being intact rock and 50% or below as highly fractured rock. Further, the time required to drill specific rock core shall also be recorded and reported as required in Chapter 6. Another way to evaluate rock is rock quality designation (RQD) which is also expressed in percentage (See ASTM D6032 - *Standard Test Method for Determining Rock Quality Designation (RQD) of Rock Core*). The time rate and RQD allow the engineer to determine which core samples can/should be tested for compressive strength. In addition, all rock cores shall be N-size and shall have an approximate 2-inch diameter.

5.4.14.1 Unconfined Compression Strength Test

This test is performed on intact rock core specimens, usually with a rock sample length of at least 2 times the diameter. All core samples shall be prepared for testing using ASTM D4543 – *Standard Practices for Preparing Rock Core as Cylindrical Test Specimens and Verifying Conformance to Dimensional Shape and Tolerances*. Provide the information contained in the report section of the ASTM. The specimen is tested using unconfined compression or uniaxial compression. The test provides data used in determining the strength of the rock, namely the uniaxial strength (q_u), shear strengths at varying pressures and varying temperatures, angle of internal friction, (angle of shearing resistance), and cohesion intercept. Unconfined compression strength testing shall be performed in accordance with ASTM D7012 - *Standard Test Methods for Compressive Strength and Elastic Moduli of Intact Rock Core Specimens under Varying States of Stress and Temperatures*. ASTM D7012 Methods C or D (unconfined compression) shall be used; however, Methods A or B (triaxial compression) may be used if required on a project.

5.5 QUALITY ASSURANCE/QUALITY CONTROL

The Quality Assurance/Quality Control (QA/QC) of the field and laboratory testing procedures/methods can have a significant impact on the results obtained from the testing. Therefore, all field and laboratory testing will require a QA/QC plan to be developed, maintained and implemented. The QA/QC plan shall follow the appropriate national, state or approved industrial standards.

5.5.1 Field Testing QA/QC Plan

All field testing shall be performed in accordance with an accepted QA/QC plan. The plan shall at a minimum establish the calibration schedule for the equipment, the method of calibration and

provide circumstances when calibration is required differently from the regularly scheduled calibration. The QA/QC plan shall be submitted to and accepted by the OES/GDS or the RPG/GDS, if requested, and shall comply with the general requirements of ASTM D3740 – *Standard Practice for Minimum Requirements for Agencies Engaged in Testing and/or Inspection of Soil and Rock as Used in Engineering Design and Construction*.

5.5.2 Laboratory Testing QA/QC Plan

All laboratories conducting geotechnical testing shall be AASHTO resource (formerly AMRL) certified. The laboratories shall only conduct those tests for which that specific laboratory is certified. If the laboratory is not certified to conduct the test, the laboratory may contract to another laboratory that is certified. If no laboratory is certified, then a QA/QC plan for that particular test shall be developed and submitted to the OES/GDS for review and approval prior to testing. The QA/QC plan shall indicate which test method is being followed, the most recent calibration of the laboratory equipment to be used and the qualifications of the personnel performing the test. For tests where there is not an established ASTM, AASHTO or State testing standard, then the laboratory may use a testing method established by another Federal or State agency. The use of other agency standards shall be approved in writing by the OES/GDS prior to conducting the test. The laboratory requesting the use of another agency standard shall prove proficiency in the standard as well as submitting a QA/QC plan for the test method.

5.6 REFERENCES

ASTM International, (2012), Annual Book of ASTM Standards, Section 4 – Construction, Volume 04.08 – Soil and Rock (I): D420 – D5876.

ASTM International, (2012), Annual Book of ASTM Standards, Section 4 – Construction, Volume 04.09 – Soil and Rock (II): D5877 - Latest.

Becker, D. E., Crooks, J. H. A., Been, K., and Jeffires, M. G. (1987), “Work as a Criterion for Determining In Situ and Yield Stresses in Clays,” *Canadian Geotechnical Journal*, Vol. 24, No. 4.

Briaud, J.-L. and Miran, J., (1992A), The Cone Penetrometer Test, (Publication No. FHWA-SA-91-043), US Department of Transportation, Office of Technology Applications, Federal Highway Administration, Washington, D.C.

Briaud, J.-L. and Miran, J., (1992B), The Flat Dilatometer Test, (Publication No. FHWA-SA-91-044), US Department of Transportation, Office of Technology Applications, Federal Highway Administration, Washington, D.C.

Casagrande, A, (1936), “The Determination of Pre-Consolidation Load and Its Practical Significance,” Proceedings of the First International Conference on Soil Mechanics, Harvard University, Cambridge, Massachusetts.

Das, M. Braja, (1994), Principles of Geotechnical Engineering, 3rd Edition, PWS Publishing Company, Boston MA.

Diehl, J. G., Martin, A. J., and Steller, R. A., (2006), “Twenty Year Retrospective on the Oyo P-S Suspension Logger” Proceedings of the 8th U.S. National Conference on Earthquake Engineering, San Francisco, California, USA.

Duncan, J. M. and Buchignani, A. L., (1976), *An Engineering Manual for Settlement Studies*, University of California at Berkeley, Berkeley, California.

Duncan, J. M., Wright, S. G. and Brandon, T. L., (2014), Soil Strength and Slope Stability, 2nd Edition, John Wiley & Sons, Inc, Hoboken, New Jersey.

Fonseca, A. V., Ferreira, C., Molina-Gomez, F., and Ramos, C., (2019), "Collection of high-quality samples in liquefiable soils using new sampling techniques", Proceedings of the XVII ESCMGE-2019, European Conference on Soil Mechanics and Geotechnical Engineering, Reykjavik, Iceland.

GEOVision, (2014), *Sample Acoustic Televiewer*, provided via E-mail from J. G. Diehl, President, GEOVision, Inc.

Marchetti, S., Monaco, P., Totani, G., and Calabrese, M., (2001), "The Flat Dilatometer Test (DMT) in Soil Investigations" Proceedings In-Situ 2001, International Conference on In-Situ Measurement of Soil Properties, Bali, Indonesia.

Mayne, P. W., Christopher, B. R., and DeJong, J., (2002), Subsurface Investigations - Geotechnical Site Characterization, (Publication No. FHWA-NHI-01-031). US Department of Transportation, National Highway Institute, Federal Highway Administration, Washington, D.C.

Sabatini, P. J., Bachus, R. C., Mayne, P. W., Schneider, J. A., and Zettler, T. E. (2002), Evaluation of Soil and Rock Properties, Geotechnical Engineering Circular No. 5, (Publication No. FHWA-IF-02-034). US Department of Transportation, Office of Bridge Technology, Federal Highway Administration, Washington, D.C.

Pineda, J. A., (2016), "Session Report on Sampling and Laboratory Testing", Geotechnical and Geophysical Site Characterization 5, Australian Geomechanics Society, Sydney, Australia.

Sowers, George F., (1970), Introductory Soil Mechanics and Foundations: Geotechnical Engineering, 4th Edition, Macmillan Publishing Co., Inc., New York, NY.

Sowers, George F. and Hedges, Charles S., (1966) "Dynamic Cone for Shallow In-Situ Penetration Testing", Vane Shear and Cone Penetration Resistance Testing of In-Situ Soils, ASTM STP399.

Spangler, Merlin G., and Handy, Richard L., (1982), Soil Engineering, 4th Edition, Harper & Row, Publishers, New York, NY.

Terzaghi, K., Peck, R. B., and Mesri, G., (1996), Soil Mechanics In Engineering Practice, 3rd Edition, John Wiley & Sons, Inc., New York.

Wightman, W. E., Jalinoos, F., Sirles, P., and Hanna, K. (2003), Application of Geophysical Methods to Highway Related Problems, (Publication No. FHWA-IF-04-021). US Department of Transportation, Central Federal Lands Highway Division, Federal Highway Administration, Lakewood, Colorado.